

Technical Report Documentation Page

1. Report No.	2. Government Accession No.	3. Recipient's Catalog No.	
4. Title and Subtitle The Interrelationships between Speed Limits, Geometry, and Driver Behavior		5. Report Date September 2018	
		6. Performing Organization Code	
7. Author(s) Peter T. Savolainen, Timothy J. Gates, Raha Hamzeie, Trevor J. Kirsch, and Qiuqi Cai		8. Performing Organization Report No.	
9. Performing Organization Name and Address Center for Transportation Research and Education Iowa State University 2711 South Loop Drive, Suite 4700 Ames, IA 50010-8664		10. Work Unit No. (TRAIS)	
		11. Contract or Grant No.	
12. Sponsoring Organization Name and Address Michigan Department of Transportation 8885 Rick Road P.O. Box 30049 Lansing, MI 48909		13. Type of Report and Period Covered Draft Final Report	
		14. Sponsoring Agency Code	
15. Supplementary Notes Visit www.intrans.iastate.edu for color pdfs of this and other research reports.			
16. Abstract The relationship between speed and safety continues to be a high-priority research topic as numerous states consider speed limit increases. This study leverages data from the second Strategic Highway Research Program (SHRP 2) Naturalistic Driving Study (NDS) to examine various aspects of driver behavior, including speed limit selection and engagement with in-vehicle distractions, as well as the impacts of these behaviors on crash risk while controlling for the effects of traffic, geometric, and environmental conditions. High-resolution time-series data are analyzed to examine how drivers adapt their speed on roadways with different posted limits, in speed limit transition areas where increases or decreases occur, as well as along horizontal curves, both with and without posted advisory speeds. The research also involves an investigation of the circumstances under which driver distraction is most prevalent. The factors associated with crash and near-crash events are compared with similar data from normal, baseline driving events across various scenarios to improve our understanding of the nature of the precipitating events. Driver response, including reaction times and deceleration rates, are examined during the course of crash and near-crash events to determine how driver response varies across various scenarios. Ultimately, this research provides important insights as to how drivers adapt their behavior and how these behaviors, in turn, influence the likelihood of being crash involved.			
17. Key Words naturalistic driving study—speed limit—speed transition areas—distracted driving—reaction time—freeway—two lane highway—horizontal curve		18. Distribution Statement No restrictions.	
19. Security Classification (of this report) Unclassified.	20. Security Classification (of this page) Unclassified.	21. No. of Pages 132	22. Price NA

THE INTERRELATIONSHIPS BETWEEN SPEED LIMITS, GEOMETRY, AND DRIVER BEHAVIOR

**Final Report
September 2018**

Principal Investigator

Peter T. Savolainen
Center for Transportation Research and Education
Iowa State University

Timothy J. Gates
Department of Civil and Environmental Engineering
Michigan State University

Research Assistant(s)

Raha Hamzeie, Trevor J. Kirsch, and Qiuqi Cai
Center for Transportation Research and Education
Iowa State University

Authors

Peter T. Savolainen, Raha Hamzeie, Trevor J. Kirsch,
Qiuqi Cai, and Timothy J. Gates

Sponsored by

Michigan Department of Transportation (MDOT)
as a part of the
Second Strategic Highway Research Program (SHRP 2)
Implementation Assistance Program (IAP)

A report from
Institute for Transportation
Iowa State University
2711 South Loop Drive, Suite 4700
Ames, IA 50010-8664
Phone: 515-294-8103
Fax: 515-294-0467
www.intrans.iastate.edu

TABLE OF CONTENTS

EXECUTIVE SUMMARY	IX
1. INTRODUCTION	1
1.1 Research Objectives.....	3
2.0 LITERATURE REVIEW	5
2.1 Operating Speed and Speed Limit	5
2.2 Operating Speed and Geometric Attributes	6
2.3 Operating Speed and Crash Risk	7
3.0 OVERVIEW OF SHRP 2 NATURALISTIC DRIVING STUDY DATA.....	11
4.0 SPEED SELECTION UNDER CONSTANT SPEED LIMITS	23
5.0 SPEED SELECTION ACROSS SPEED LIMIT TRANSITION AREAS.....	39
6.0 SPEED SELECTION ON HORIZONTAL CURVES	50
7.0 CRASH RISKS ON FREEWAYS AND TWO-LANE HIGHWAYS	71
7.1 Data Summary	71
7.2 Statistical Methods.....	72
8.0 PREVALENCE AND IMPACTS OF DISTRACTED DRIVING.....	77
8.1 Data Summary	78
8.2 Statistical Methods.....	86
8.3 Results and Discussion	87
9.0 DRIVER RESPONSE DURING CRASH/NEAR-CRASH EVENTS.....	91
9.1 Prior Research on Driver Response	92
9.2 Data Summary	94
9.3 Statistical Methods.....	99
9.4 Results and Discussion	100
10.0 SUMMARY AND CONCLUSIONS	107
10.1 Speed Selection under Constant Speed Limits	107
10.2 Speed Selection across Speed Limit Transition Areas	108
10.3 Speed Selection along Horizontal Curves.....	109
10.4 Crash Risks on Freeways and Two-Lane Highways	110
10.5 Prevalence and Impacts of Distracted Driving	111
10.6 Driver Response during Crash/Near-Crash Events.....	112
10.7 Limitations	113
10.8 Future Research	113
11.0 REFERENCES	115

LIST OF FIGURES

FIGURE 1	Fatality Rates by Maximum Speed Limit (Davis et al., 2015).....	1
FIGURE 2	Maximum Speed Limits on Limited Access Freeways, April 2017.	3
FIGURE 3	Data acquisition system schematic (Antin et al., 2015).	12
FIGURE 4	Fields of View for the data acquisition system.	12
FIGURE 5	Composite snapshot of four continuous video camera views (Antin et al., 2015)....	13
FIGURE 6	Mobile Van Used to Collect Data for Roadway Information Database.....	17
FIGURE 7	Collected links for SHRP 2 roadway information database.....	17
FIGURE 8	Map of the obtained traces.	19
FIGURE 9	A snapshot of the conflation process.....	20
FIGURE 10	Flow chart of the logic used to resolve the conflation issues.....	21
FIGURE 11	Example Speed Profiles of a Baseline and a Near-Crash Posted at 70 mph.	25
FIGURE 12	Box Plots of Mean Travel Speed by Posted Speed Limit on Freeways.	26
FIGURE 13	Boxplots of Mean Speed by Posted Speed Limit and Traffic Density on Freeways.	27
FIGURE 14	Box Plot of Mean Travel Speed by Posted Speed Limit on Two-Lane Highways. .	29
FIGURE 15	Boxplots of Mean Speed by Posted Speed Limit and Traffic Density on Two-Lane Highways.	30
FIGURE 16	Example of a Trace with and without Location Interpolation.....	40
FIGURE 17	Upstream Travel Speeds by Posted Speed Limit and Size of Upcoming Speed Limit Change on Freeways.	42
FIGURE 18	Upstream Travel Speed by Posted Speed Limit and Size of Upcoming Speed Limit Change on Two-lane Highways.....	43
FIGURE 19	Overview of Reduced Video Data for Freeways Transition Areas.....	44
FIGURE 20	Overview of Reduced Video Data for Two-Lane Highway Transition Areas.....	44
FIGURE 21	Horizontal Alignment Signs and Plaques Outlined in MUTCD (FHWA, 2009)....	52
FIGURE 22	Upstream Travel Speed by Posted Speed Limit and Advisory Speed.....	56
FIGURE 23	Overview of the Reduced Video Data for Curves.....	57
FIGURE 24	FDA Results for a Curve Posted at 35 mph and Advisory Sign of 30 mph.	65
FIGURE 25	FDA Results for a Curve Posted at 45 mph and Advisory Sign of 35 mph.	67
FIGURE 26	FDA Results for a Curve Posted at 55 mph and Advisory Sign of 40 mph.	68
FIGURE 27	FDA Results for a Curve Posted at 45 mph and Advisory Sign of 20 mph.	69

LIST OF TABLES

TABLE 1. RID Shapefiles and the Associated Extracted Information	20
TABLE 2. Summary Statistics of Freeway Traces Under Constant Speed Limit	28
TABLE 3. Summary Statistics of Two-Lane Traces Under Constant Speed Limit	31
TABLE 4. Mixed Effect Linear Regression Model for Mean Speed on Freeways	33
TABLE 5. Mixed Effect Linear Regression Model for Speed Standard Deviation on Freeways	35
TABLE 6. Mixed Effect Linear Regression Model for Mean Speed on Two-Lane Highways	36
TABLE 7. Mixed Effect Linear Regression Model for Speed Standard Deviation on Two-Lane Highways	37
TABLE 8. Number of Obtained Trips by Speed Limit and Size of Speed Limit Change on Freeways	41
TABLE 9. Number of Obtained Traces by Speed Limit and Size of Speed Limit Change on Two- Lane Highways	42
TABLE 10. Mixed Effect Linear Regression Model for Travel Speed across Speed Limit Transition Areas on Freeways	46
TABLE 11. Mixed Effect Linear Regression Model for Travel Speed across Speed Limit Transition Areas on Two-Lane Highways	48
TABLE 12. MUTCD Criteria for Selection of Horizontal Alignment Sign (FHWA, 2009)	50
TABLE 13. Observed Average Speed Reduction Reported (Chowdury et al., 1991)	53
TABLE 14. Frequency Distribution of Obtained Trips by Posted Speed Limit and Suggested Speed Reduction	55
TABLE 15. Mixed Effect Linear Regression Model for Travel Speed across Horizontal Curves – No Distance Variable Included	61
TABLE 16. Mixed Effect Linear Regression Model for Travel Speed across Horizontal Curves – Step Function	63
TABLE 17. Paired Two-Sample t-test Results for a Curve Posted at 35 mph and Advisory Sign of 30 mph	66
TABLE 18. Paired Two-Sample t-test Results for a Curve Posted at 45 mph and Advisory Sign of 35 mph	67
TABLE 19. Paired Two-Sample t-test Results for a Curve Posted at 55 mph and Advisory Sign of 40 mph	68
TABLE 20. Paired Two-Sample t-test Results for a Curve Posted at 45 mph and Advisory Sign of 20 mph	70
TABLE 21. Random Effect Logistic Regression Model for Crash/Near-Crash Risk, Freeways	73
TABLE 22. Random Effects Logistic Regression Model for Crash/Near-Crash Risk, Two-Lane Highways	74
TABLE 23. Descriptive Statistics of Time-Series Data	81
TABLE 24. Descriptive Statistics of RID Geometrics, Weather Conditions, and Traffic Congestion	82
TABLE 25. Descriptive Statistics of Driver Characteristics	83
TABLE 26. Descriptive Statistics of Driver Behavioral Survey Results	85
TABLE 27. Random effects logistic regression model for any distraction	88
TABLE 28. Random effects logistic regression model for cell phone distraction	89
TABLE 29. Random effects logistic regression model for crash risk	90
TABLE 30. Summary Statistics for Driver Response Data	98

TABLE 30. Random Effect Linear Regression Model for the Reaction Time102
TABLE 31. Random Effect Linear Regression Model For Deceleration Rate106

EXECUTIVE SUMMARY

The topic of regulatory speed limits continues to be an important transportation policy issue. Speed limits are generally determined in consideration of roadway characteristics, traffic volumes, and environmental conditions. Prior research has shown that traffic crashes and fatalities generally tend to increase with higher speed limits. However, on higher speed facilities, the design speed is often significantly higher than the posted limit, creating the potential for significant non-compliance by motorists. This explains, in part, why at least 14 states have increased speed limits on rural freeways between 2012 and 2018.

While the research literature suggests increases in both mean speed and speed variance have adverse impacts on safety, distinguishing the nature of these relationships is challenging. This is due to various factors, including imprecision in determining the exact time at which a crash occurred, as well as the specific traffic conditions immediately preceding the crash. Further, much of the prior research in this area has been limited to using aggregate data for specific road segments where detailed driver information was not available. As such, it is difficult to infer how the behaviors of individual drivers may vary in response to different speed limits, as well as how these behavioral changes may impact crash risk.

The data from the second Strategic Highway Research Program (SHRP 2) Naturalistic Driving Study (NDS) allows for more extensive investigation of the behavior of individual drivers, which addresses several of the analytical concerns noted above. The SHRP 2 NDS allows for an investigation of how drivers adapt their behavior in response to the speed limit and other changes in roadway geometry, traffic conditions, and environmental characteristics. These data also allow for close investigation of driver behavior preceding the occurrence of crash and near-crash events. To this end, this study aims to improve our understanding of fundamental aspects of speed selection behavior.

Time-series data from the SHRP 2 NDS were leveraged to examine how drivers adapt their speeds: 1) under constant speed limits; 2) across speed limit transition areas; and 3) along horizontal curves. These speed data were subsequently used to investigate the speed-safety relationship by examining crash/near-crash risk on both freeways and two-lane highways. The research also examined driver distraction, including the circumstances under which distraction was most prevalent, as well as the effects of distraction on crash risk. Lastly, driver behaviors were examined leading up to crash and near-crash events to assess how reaction times and deceleration rates varied among drivers involved in these safety-critical events.

Higher speed limits were found to result in higher travel speeds, though the increases in travel speeds tended to be less pronounced at higher posted limits. In addition to responding to changes in speed limits, drivers were found to adapt their speeds based upon changes in the roadway environment, such as the introduction of horizontal curves, as well as in response to traffic congestion, adverse weather, and work zone environments.

On freeways, speeds tended to be more variable at lower posted limits, particularly at 55 and 60 mph. Likewise, speed fluctuations were generally higher at lower speed limits on two-lane highways, as well. Speed standard deviation was increased under traffic congestion, along horizontal curves, and in presence of on-street parking which all probably relates back to changes in roadway environment, and especially are indicative of more urban areas.

In transition areas, where speed limit increases and decreases occurred on both freeways and two-lane highways, the results suggest that speed changes are very gradual in the areas immediately upstream and downstream of where the posted limit changes. The differences between mean speeds upstream of the new regulatory speed limit were found to be much lower compared to segments with similar constant speed limits, which is indicative of drivers changing their behavior significantly upstream of the new speed limit introduction. More pronounced changes were observed where limit reductions were introduced, though these decreases in mean speeds were still relatively small in consideration of the magnitude of the change in limits.

Drivers were also found to adapt their speeds on horizontal curves, particularly on sharper (i.e., smaller radius) curves. These speed reductions were greater in magnitude when advisory speed signs were present. Further, the reductions were also larger in magnitude when the differences between the posted limit and the advisory speed were larger, as well. However, the reductions were found to be markedly smaller than (approximately half of) the recommended advisory speed. Further analysis revealed that drivers tend to start accelerating back to baseline speed while within the curve when smaller differences between the posted speed limit and the advisory speed was present.

In addition to examining driver speed selection behavior, a series of logistic regression models were estimated to identify how speed metrics and various other factors influence crash risk. The results showed that increases in the variability of speeds among individual drivers over time and space during 20-s event intervals led to increases in the risk of crash- or near-crash events. This variability in speeds may be reflective of several factors, such as traffic congestion or differences in individual driving behaviors, which collectively contribute to an increased risk of rear-end or side-swipe collisions.

This study also provides important insights into driver distraction, as well as the influence of distractions on crash/near-crash risk. Driver distraction tended to be less prevalent under adverse weather conditions, as well as among certain subsets of the driving population while distractions were more likely under clear weather conditions and higher levels of service.

Risk analyses were conducted to determine which factors were likely to increase or decrease the likelihood of a crash or near-crash event. Females and risk-averse drivers were less likely to be involved in crash/near-crash events. Crashes were more likely on roadways with greater numbers of lanes, as well as among drivers who engaged in other high-risk behaviors.

Lastly, the study provides important insights into driver behavior leading up to crash and near-crash events. The investigations focused on understanding how reaction time, deceleration rate, and speed selection varied with respect to traffic conditions, roadway geometry, driver

characteristics, and behavioral factors. Driver response and braking behaviors were examined under unexpected situations where braking was required.

The results show that reaction time varied based upon the type of crash/near-crash event, the gender of driver, and whether the driver was distracted over the course of the driving event. Particularly, the drivers were slow to respond to the braking of leading vehicles. The reaction time was longer for distracted drivers and males. Other factors such as the age of the driver, weather conditions, and the road surface showed no correlation with the reaction time. Drivers also tended to brake at different rates depending upon the driving context. The rate of braking was affected by the initial speed, the grade of the roadway, and the type of scenario that required the braking to occur.

Ultimately, the substantial breadth and depth of data elements available through the NDS for crash, near-crash, and baseline driving events provide a unique opportunity to identify salient factors impacting traffic safety at the level of individual drivers. The findings from this study are largely supportive of the extant research literature and identified several important considerations for transportation agencies in considering policies, programs, and countermeasures to address speed-related concerns, distracted driving, and various design issues.

1. INTRODUCTION

Maximum regulatory speed limits are determined in consideration of roadway characteristics, traffic volumes, and environmental conditions to notify drivers of the highest speed one can travel under most conditions. Since the introduction of maximum speed limits, there has been significant debate as to how speed limits are most appropriately determined for specific locations. Research studies have generally shown that increasing speed limits result in more crashes, with particular increases in the number of fatal crashes. However, road users generally favor higher posted speed limits due to the resulting increases in travel speeds and associated reductions in travel time.

Therefore, the influence of speed limits, traffic characteristics, and roadway geometry on driver speed selection, as well as the interrelationship between speed and crash risk, continue to be critical areas of interest for transportation agencies across the United States. A recent longitudinal study found states with 70-mph and 75-mph maximum speed limits on rural interstates tended to experience 31 percent and 54 percent more fatalities, respectively, as compared to states with 60-65 mph maximum limits (Davis et al. 2015). Figure 1 shows fatality rates have generally decreased across rural interstates within each of these groups since 1999, but there remains a persistently higher rate among those states with higher limits.

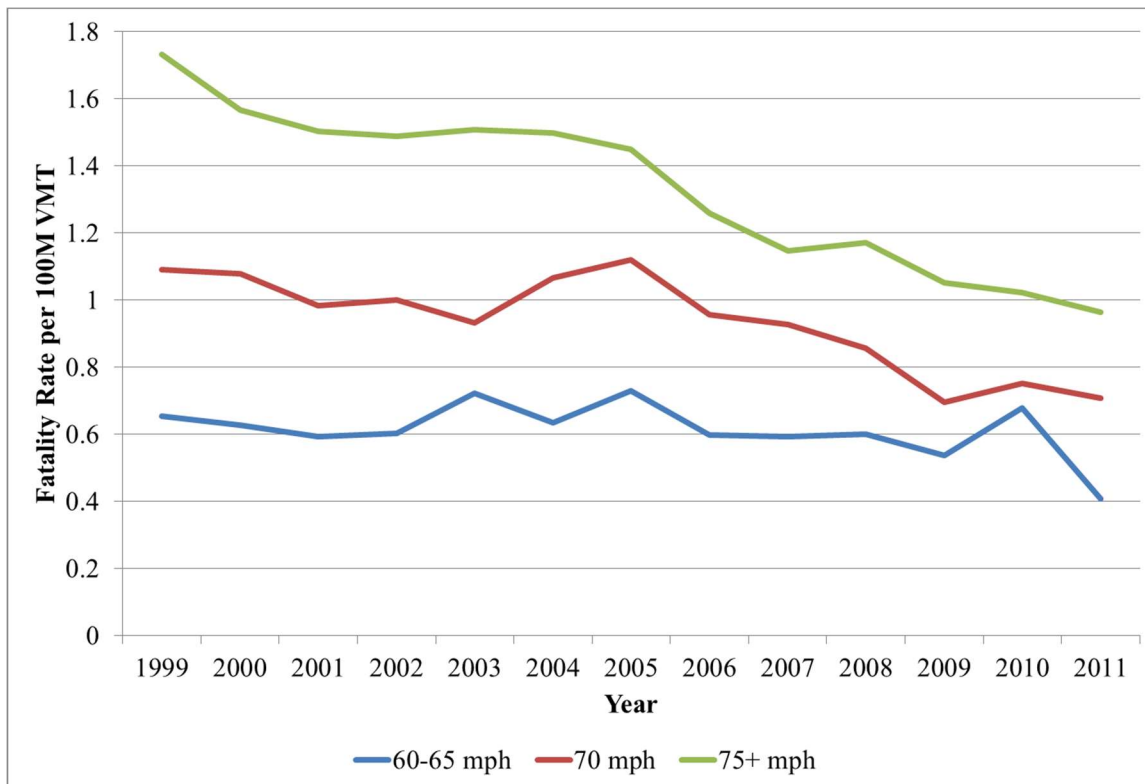

FIGURE 1 Fatality Rates by Maximum Speed Limit (Davis et al., 2015).

These findings reinforce the results of numerous prior studies that showed lower speed limits to result in safety benefits (Forester et al., 1984; Fowles and Loeb, 1989; Levy and Asch, 1989;

Zlatoper, 1991; Dart, 1977; Weckesser et al., 1977; Deen and Godwin, 1985; Burritt et al., 1976; Greenstone, 2002; Ledolter and Chan, 1996; Baum et al., 1989; Bham et al., 1992; McKnight and Klein, 1990; Wagenaar et al., 1990; Gallaher et al., 1989; Upchurch, 1989; Farmer et al., 1999; Patterson et al., 2002; Haselton et al., 2002). While less research has been conducted on high-speed undivided highways, recent research has shown higher speeds are also associated with increased safety risks on these roads, as well (Hamzeie et al., 2017a).

Despite these findings, at least 14 states have increased speed limits on rural freeways since early 2012. The current maximum limits for rural freeways are summarized in Figure 2 for all states. Over this same time period, four states have increased speed limits on undivided rural highways while additional states have considered, or are considering, increases on various road types. In contrast to earlier speed limit increases, which were often implemented on a system-wide basis, the recent changes have been implemented selectively in consideration of segment-specific factors such as the existing mean and 85th percentile speeds, speed variance, and recent crash history.

While the research literature generally suggests differences in mean speed and speed variance both impact safety performance (Solomon, 1964; Cirillo, 1968; West and Dunn, 1971; Garber and Ehrhart, 2000), distinguishing the nature of these relationships is challenging. This is due to various factors, including imprecision in determining the exact time at which a crash occurred, as well as the specific traffic conditions immediately preceding the crash. Further, much of the prior research in this area has been limited to using aggregate data for specific road segments where detailed driver information was not available. As such, it is difficult to infer how the behaviors of individual drivers may vary in response to different speed limits, as well as how these behavioral changes may impact crash risk.

The second Strategic Highway Research Program (SHRP 2) Naturalistic Driving Study (NDS) allows for more extensive investigation of the behavior of individual drivers, which addresses several of the analytical concerns noted above. The SHRP 2 NDS involved the collection of detailed data at 10 Hz intervals from more than 3,400 drivers, allowing for an investigation of how drivers adapt their behavior in response to the speed limit and other changes in roadway geometry, traffic conditions, and environmental characteristics. These data also allow for close investigation of driver behavior preceding the occurrence of crash and near-crash events. To date, the majority of research studies in this area have relied predominantly on police crash reports or post-crash surveys. Failing to properly account for precipitating events and driver behaviors that led to the incident may inhibit proper identification of contributing factors.

This study aims to address this gap and to improve our understanding of fundamental aspects of speed selection behavior using naturalistic driving data. The research also involves an investigation of driver distraction, as well as how speed selection, driver distraction, and other factors influence the likelihood of a driver being involved in a crash or near-crash event.

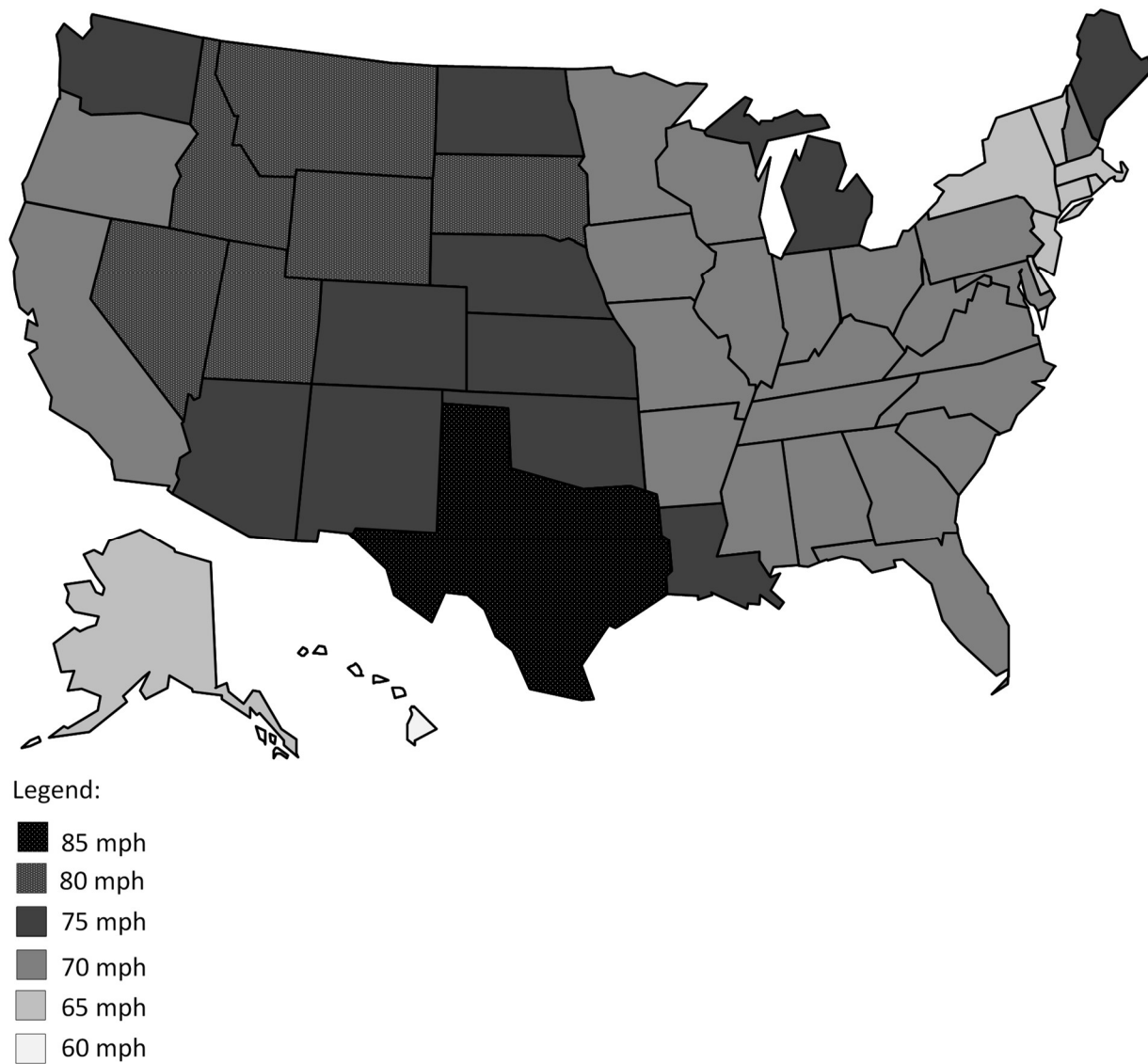

FIGURE 2 Maximum Speed Limits on Limited Access Freeways, April 2017.

1.1 Research Objectives

In order to better understand the differences in driver behavior that may result from speed limit policies, this study involves a detailed assessment of the behavior of individual drivers using the SHRP 2 Safety Data. The SHRP2 Safety Data includes very detailed information on individual driver behavior from the NDS, as well similarly detailed information regarding the driving environment from the related Roadway Information Database (RID). Collectively, these data allow for an unparalleled assessment of how driver speed selection changes in response to the speed limit while controlling for important roadway, environmental, and driver characteristics.

The goal of this study, conducted as a part of the SHRP2 Implementation Assistance Program, is to leverage the information from the NDS and RID to examine the interrelationships between driver, vehicle, and roadway factors with driver speed selection and crash risk. A variety of research questions are addressed as part of this study:

- How is driver speed selection affected by roadway geometry (e.g., horizontal and vertical curvature) and traffic characteristics (e.g., congestion)?
- How do drivers respond to visual cues, such as curve advisory signs, and over what dimensions (both temporal and spatial) do these effects occur?
- What are the impacts of in-vehicle distraction on driver behavior and under what circumstances is distraction a particular concern?
- What are the impacts of driver behavior, roadway geometry, traffic conditions, and environmental factors on crash risk?

To address these questions, six primary analyses were conducted using various subsets of the NDS data. Chapter 2 presents a brief overview of the research literature related to speed and safety. Chapter 3 provides a high-level summary of the NDS, the RID, and other data sources that were utilized as a part of this project. Chapter 10 provides a succinct summary of key results, conclusions, and directions for future research. The remaining chapters, which focus on six general topic areas, are briefly summarized here:

1. **Speed Selection under Constant Speed Limits (Chapter 4)** – Driver speed selection is examined on freeways and two-lane highways where the speed limit remained constant over the duration of the driving event. Analyses focus on the impacts of driver, geometric, and environmental factors on the mean and standard deviation of travel speeds over the course of these events.
2. **Driver Response during Crash/Near-Crash Events (Chapter 5)** – Driver behavior leading up to crash and near-crash events is evaluated, including an examination of reaction times and deceleration rates and how these parameters vary based upon driver and roadway-related characteristics.
3. **Speed Selection across Speed Limit Transition Areas (Chapter 6)** – Separate analyses were conducted for freeways and two-lane highways in transition areas where the posted speed limits were increased or decreased. Speed profiles were examined upstream and downstream to discern how drivers adjust speed in response to changes in posted limits.
4. **Speed Selection along Horizontal Curves (Chapter 7)** – Driver speed profiles were compared across horizontal curves, with particular emphasis on the effects of curve characteristics, as well as the presence of advisory speed signs. The locations were selected to cover a wide range of speed limit and advisory speed combinations.
5. **Crash Risks on Freeways and Two-Lane Highways (Chapter 8)** – The likelihood of a crash or near-crash occurrence was evaluated in consideration of driver behavior (e.g., speed selection, distraction, and various roadway and environmental conditions).
6. **Prevalence and Impacts of Distracted Driving (Chapter 9)** – High fidelity data related to in-vehicle distraction were analyzed to understand the circumstances under which distraction was most prevalent, as well as the characteristics of the drivers who were most prone to engaging in various types of distraction.

2.0 LITERATURE REVIEW

2.1 Operating Speed and Speed Limit

Speed management has long been a significant focus area in traffic safety research. The topic of maximum speed limits emerged as a particular issue in the United States in 1974 following the passage of the Emergency Highway Energy Conservation Act when the 55-mph National Maximum Speed Limit (NMSL) was established. This limit was introduced to reduce the operating speed with an aim to lower fuel consumption. While the lower speed limit was shown to lead to significant decreases in traffic fatalities, compliance with this maximum limit was low on higher speed facilities, particularly on interstates where the design speed was often greater than the 55-mph limit. Given this issue, the Surface Transportation and Uniform Relocation Assistance Act (STURAA) was introduced later in 1987 which permitted a maximum limit of 65 mph on rural interstates in areas with populations below 50,000 people. Following implementing each of these speed limit policies, numerous studies examined the relationship between posted speed limits and the frequency and severity of traffic crashes. Ultimately, in 1995 the NMSL was repealed and states were given the entire authority to determine the posted speed limits in their jurisdictions. Since the dawn of maximum speed limit, numerous studies aimed at examining its impacts on travel speeds, synopses of some prominent ones are described below.

Parker (1997) conducted an extensive evaluation study, using data from 1985 to 1992 on non-limited access highways, to evaluate the effect of changing the posted speed limit on driver behavior. The maximum posted speed limit on the select roadways was 55 mph at that time. However, during the course of study speed limits were increased or decreased on a number of segments along these roadways. Subsequently, driver behavior data along with crash data were collected from 22 states to study any potential interrelationship. These changes in the speed limit included either increasing or decreasing the maximum permitted speed along the roadway segments. The limits were lowered by 5, 10, 15, or 20 mph or raised by 5, 10, or 15 mph. Surprisingly, less than 1.5 mph change in the speed was reported after the implementation of these changes. This study findings revealed that drivers generally tend to select their speeds on non-limited access highways based on the roadway geometry rather than solely the speed limit.

A study conducted by Wilmot and Khanal (1999), leveraged the results from numerous studies all over the world to ascertain the impact of speed limit on travel speeds. Similar to previous study, they concluded that drivers do not necessarily follow the speed limit to adjust their travel speed, but rather choose the speed they personally perceive as safe.

In 2002, a national survey of more than 4,000 drivers examined general attitudes regarding speed limit violations and other high-risk driving behavior. It was reported that most drivers believe they can travel approximately 6 to 8 mph over the posted limit before getting cited by law enforcements while respondents believed they should be able to drive as much as 10 mph above the limit before receiving a citation. This study also found that drivers believe the most influential factors when selecting their speed are weather conditions, their perception of what speeds can be regarded as 'safe', the posted speed limit, traffic volume and level of congestion, and how experienced they feel they are on a particular road given previous travels (Royal, 2003).

Kockelman et al. (2006) studied the impact of raising speed limits on operating speeds, as well as the associated variability in speeds on high-speed roadways. The findings demonstrated that increases in the operating speed were, on average, less than half of the actual amount with which the speed limit had been raised. The authors also noted that the average speed and the speed variability are more influenced by roadway geometry and cross-sectional characteristics as compared to posted speed limits. These findings are largely reflective of driver opinions on speed limits.

A survey of freeway users found that, on average, respondents drove 11 mph over the speed limit on interstates posted at 55 mph, 9 mph over the speed limit on interstates posted at 65 mph, and 8 mph over the speed limit on interstates posted at 70 mph (Mannering, 2007). Also, male drivers were shown to drive at higher speeds as compared to females. Driver age was also found to be inversely correlated with speeding.

Utah is one of the states that experienced speed limit increases over the past years. In November 2010 and October 2013 speed limit was increased from 75 mph to 80 mph over approximately 300 miles of rural interstates in Utah. In a study conducted by Hu (2017), travel speeds were investigated at 80 mph zones and nearby locations that experience spillover effects, as well as more distant segments that retained the 75 mph as control locations. Log-linear regression models were estimated to evaluate the impact of increased speed limit on travel speeds. The author reported the mean travel speed to be 4.1% and 3.5% higher across 80 mph segments and nearby locations, respectively. In addition, the probability of exceeding 80, 85, or 90 mph was examined through estimating a series of logistic regression models. The results showed that increasing speed limits not only is associated with higher travel speeds, but also results in greater probability of exceeding the new speed limit.

In a similar study, speed data were collected and analyzed over 19 sites across rural interstate highways (Johnson and Murray, 2010). These locations covered a variety of speed limits, uniform or differential, and were all flat and straight over two miles upstream of the study site. The analysis of operating speeds for those vehicles with no leading vehicle revealed that drivers tend to exceed the posted speed limit regardless of its magnitude. Aggregated speed data showed a compliance rate of only 7% on roadways posted at 55 mph, whereas this measure increased to 49% for locations posted at 75 mph.

2.2 Operating Speed and Geometric Attributes

The American Association of State Highway and Transportation Officials (AASHTO) notes that driving speeds are affected by the physical characteristics of the road, weather, other vehicles, and the speed limit (AASHTO, 2011). Among these, road design is a principal determinant of driving speeds. Geometric factors tend to have particularly pronounced impacts on crashes. Ultimately, many factors affect speed selection beyond just road geometry and posted limit as shown by prior research in this area (Emmerson, 1969; McLean, 1981; Glennon et al., 1983; Lamm and Choueiri, 1987; Kanellaidis et al., 1990).

Fitzpatrick and Collins (2000) developed regression equations to evaluate factors affecting the operating speed along horizontal and vertical curves, as well as tangent segments. It was concluded that the most effective single parameter to model the speed along horizontal curves is the inverse of the curve radius. Operating speeds along horizontal curves with radius greater than 800 m were found to be very similar to that of tangent segments. However, the operating speed decreases significantly on horizontal curves with radius less than 250 m.

Collectively, existing literature suggests that degree of curvature, length of curve, and deflection angle are salient factors to predict the operating speed along horizontal curves. Voigt et al. proposed an equation to estimate the 85th percentile speed along horizontal curves in which the degree of curvature, curve length, deflection angle, and superelevation were statistically significant (Voigt, 1996).

Schurr et al. (2002) utilized the data from 40 different sites across the state of Nebraska to estimate the mean speed of the traffic. In addition to deflection angle and curve length, the posted speed limit was found to be a significant predictor for the mean speed. A one-mph increase in speed limit resulted in only a 0.27 mph increase in mean speeds. However, it should be noted these curves were generally located along high-speed roadways. In addition to the operating speed along horizontal curves, regression models were developed for the operating speed on tangent segments in advance of the curves, where a one-mph increase in posted speed was associated with a 0.51-mph increase in mean speeds. Ultimately, the existing research literature suggests that the operating speed is not also affected by the posted speed limit, but also by the geometric characteristics when the geometric design deviates from base conditions (e.g. presence of horizontal curves).

The majority of studies that evaluated impacts of geometric attributes on travel speeds have been focused on curves since speeds on such segments are significantly influenced by a few known variables including curve radius and superelevation. A 2000 study examined travel speeds on tangent sections on two-lane rural highways. They grouped the study segments into four different categories based on the tangent length and the radii of the preceding and succeeding curves. They proposed numerical equations for speed estimation across each group by computing a geometric measure that was comprised of the tangent length, and the preceding and succeeding curves radii. However, they were unable to identify any association between travel speed and other geometric characteristics like presence of vertical curves (Polus et al., 2000).

2.3 Operating Speed and Crash Risk

Traffic speeds play a significant role in roadway safety. The risk of being involved in a crash, as well as the severity of the outcome could dramatically be affected by the speed of the moving vehicle (Elvik, 2005). Traveling at higher speeds results in longer stopping distance, as well as less maneuverability, and requires more prompt reaction to a certain incident or change in the roadway (Aarts and Van Schagen, 2006).

In an early study conducted on 600 miles of rural highways, three-quarters of which were two-lane highways, Solomon (1964) reported that for speeds less than 50 mph, the involvement rate

of vehicles in crashes (i.e. the number of vehicles involved in accidents per 100 million vehicle-miles travel) decreases as the speed increases. Solomon (1964) proposed that the probability of getting involved in a crash per vehicle-miles travel as a function of vehicle speed follows a U-shaped curve. Later, while the Solomon's curve was replicated in some other research studies (Cirillo, 1968; Munden, 1967) with some modification, criticism arose in subsequent research for the use of estimated pre-crash speeds of the involved vehicle, which could bias the results (White and Nelson, 1970).

Baum et al. (1989) used data available through Fatal Accident Reporting System (FARS) to compare the fatality rates between states that imposed higher speed limits versus those that retained the 55-mph speed limit. The data from 38 states with increased speed limit were aggregated across the months with higher speed limits in 1987, as well as the same months from 1982 to 1986. The results showed the number of fatalities on rural interstates were significantly higher after the enactment of STURAA as compared to data from the five prior years.

New Mexico was the first state to utilize 65-mph speed limits after the passage of legislations in April 1987. As a result, a before and after analysis was conducted by Gallaher et al. (1989) to compare the rate of casualties along these roadways. The results indicated that the rate of fatal crashes had increased by 2.9 per 100 million vehicle-miles traveled (VMT) during one year after period, while 1.5 per 100 million VMT increase was predicted using the same trend based on the data from preceding five years.

The speed limit on rural limited access highways in state of Michigan was raised to 65-mph effective January 1988. As a result, a study was conducted to examine the number of fatalities resulting from this change (Wagenaar et al., 1990). To this end, the number and rates of crashes, as well as the injuries and fatalities were collected along the segments where the speed limit was raised, as well as those for which the limit was retained. The analyses revealed that roadways where the speed limit was raised were associated with 19.2 percent higher fatalities, while this increase jumped up to 39.8 percent for major injuries, as well as 25.4 percent for moderate injuries. Also, they noticed that fatalities increased even on roadways which maintained 55-mph speed limit, suggesting that imposing higher speed limit may also have spillover effects on other roadway segments.

One concern that arose while assessing the effect of 65-mph speed limit on crash rates was that these rates should not be examined solely on interstates in isolation from the rest of a network. In a study conducted in 1997, Lave and Elias (1994) proposed that the increase in the speed limit on interstates had resulted in reallocation of traffic and drivers. Consequently, they concluded that this reallocation in the system addresses the increased fatality rates on interstates. They also showed that imposing 65-mph speed limit on rural interstates resulted in a 3.4-5.1 percent reduction in the statewide fatality rates.

Greenstone (2002) reexamined the findings of Lave and Elias (1994). This study utilized similar data over a slightly shorter period of time from 1982 to 1990. This study also found evidence as to a modest decline in the statewide fatality rates. Although the findings showed a significant increase in the fatality rates on interstates, a large reduction in the same measure of interest was

reported on urban non-interstates. In addition, unlike the previous study, the author found no evidence regarding the reallocation phenomenon on roadway networks (Greenstone, 2002).

A similar study was designed to examine the effect of the introduction of 65-mph speed limit in state of Ohio (Pant et al., 1992). A before and after analysis was conducted using 36 months of data before and after the implementation. In contrast to prior literature, Pant et al. (1992) were not able to identify any significant difference in the number of fatalities between rural interstate highways posted at 65-mph as compared to those which retained a 55-mph posted limit. However, slight increases were reported with respect to the number of injury and property damage only (PDO) crashes on roadway stretches that had been posted at 65-mph. In addition, rural interstates posted at 55-mph were found to be associated with lower rates of injury and PDO crashes as compared to before implementation period. Consequently, no evidence was found as to the spillover effect which had been proposed by some other studies.

The implementation of higher speed limits was thought to be associated with some economic benefits most important of which was travel time. However, the change in the number of fatal and injury crashes might not justify such a modification. In order to address this concern, speed and volume data, as well as crash data were obtained from Iowa Department of Transportation on four main roadway classes: 1) rural interstates; 2) rural primary roads; 3) rural secondary roads; and 4) urban interstates. However, the 65-mph speed limit was only imposed on rural interstates. This study found 38.2 percent increase in the number of fatal crashes on rural interstates, whereas a 15.6 percent reduction in major-injury crashes was observed on the same roadway segments. However, significant reduction in both fatal and major-injury crashes was reported on rural primary roads, rural secondary roads, and urban interstates (Ledolter and Chan, 1996).

Farmer et al. (1999) compared the number of fatalities across 12 states which increased the posted speed limit to 70-mph in 1996 with the similar data from 1990 to 1995. Rural and urban interstates, as well as freeways were included in this study. States with higher posted speed limit were associated with 12 percent increase in the number of fatalities on interstates and freeways. However, on other types of roadways, this increase was only three percent, while the overall increase on all types of roadways was 6 percent.

Elvik (2005) conducted an extensive review of 460 studies about the speed and road safety associations and concluded that there is a robust relationship between them. It was also revealed that the effect of a 10 percent change in the mean speed of traffic on traffic fatalities is more pronounced as compared to a 10 percent change in traffic volume. Subsequently, in an extensive review, Aarts et al. (2006) provided a thorough list of the studies that had been conducted to investigate the relation between crash risks and speed in general. They concluded that crash rates increase exponentially for individual vehicles that increase their speed and this increase is more pronounced in minor/urban roads as compared to major/rural highways.

In a more recent study, Kockelman et al. (2006) investigated the safety impacts of raising speed limit from 55 to 65 mph and from 65 to 75 mph. Total and fatal crashes were shown to increase by 3 and 28 percent when raising speed limit from 55 to 65 mph. In addition, they estimated less

pronounced increases by raising the posted limits to 75 mph. It was shown that a 10-mph increase from 65 mph to 75 mph would result in total and fatal crashes to go up by 0.6 and 13 percent, respectively.

The investigation of the effect of speed on crash risk, as well as the crash frequency was not limited to the United States. This high-interest area in traffic safety and operation has also been investigated by researchers all over the world. Aljanahi et al. (1999) developed models to investigate how crash rates change with regard to various roadway and traffic characteristics including speed. The crash rates were explored on divided highways in two sets of locations, one in UK and the other one in Bahrain. They proposed that substantial safety improvement could be achieved either by mandating lower speed limits or reducing the spread of vehicle speeds. They also found that in UK sites which had lower crash rates, there is a strong statistical relationship between crash counts and the variability of traffic speed, while the results for Bahrain, which was associated with higher accident rates, indicated that mean speed of the traffic is a stronger predictor of crash rates.

Fildes et al. (1991) conducted a self-report study in both rural and urban highways in Australia to investigate the effects of speed selection and speed spread on crash rates. The study was performed on two urban and two rural roads with speed limits of 60 km/h and 100 km/h respectively. Drivers who drove at a speed below V15 or above V85 were pulled over and asked about their crash history during last 5 years. Fast drivers had experienced more crashes recently and there was an exponential relationship both for urban and rural highways with a much steeper curve for urban roads. In another similar study by Maycock et al. (1998), a 13.1 percent increase in crash liability was reported in response to a one percent increase in speed.

In July 2003, the speed limit on 1100 km of rural roads in South Australia was reduced from 110 km/h to 100 km/h. Using crash data from two years of before and two years of after speed limit reduction, Long et al. (2006) found only a 1.9 km/h reduction in the average speed of the vehicles and a 20 percent reduction in casualty crashes. Also, a follow up report on the same roadway segments analyzed ten years of before and after speed reduction data and compared the results with control segments where the speed limit was still 110 km/h. It was revealed that the control segments, which still had the same speed limit, had also experienced a long-term trend of crash counts reduction. A pronounced drop in casualty crashes was still apparent.

Also, the results of a study on a number of divided segments in Naples-Candela Italy, showed that the absolute value of the operating speed difference in the tangent-to-curve transition is a significant predictor for total crash counts (Montella and Imbriani, 2015).

In summary, while the existing research literature generally shows higher speed limits to introduce adverse safety impacts, there are some examples where increasing limits was shown to have marginal or positive impacts on safety. Naturalistic driving study data provide a unique opportunity to better understand how roadway geometry, traffic conditions, and various factors both internal and external to the vehicle affect driver behavior, speed selection, and crash risk.

3.0 OVERVIEW OF SHRP 2 NATURALISTIC DRIVING STUDY DATA

The second Strategic Highway Research Program (SHRP2) was aimed at identifying solutions to three major transportation challenges at the national level: improving transportation safety to save lives; reducing congestion; and improving methods for renewing roads and bridges which would ultimately result in improving the quality of life. Extensive data collection has been conducted for the purpose of various aspects of the SHRP 2, providing a unique opportunity to address different research questions that were not possible to examine before. Within the context of traffic safety, this includes a large-scale data collection exercise across six different states, including Florida, Indiana, New York, North Carolina, Pennsylvania, and Washington. This section includes details of the background and data acquisition systems used to conduct this study of naturalistic driving behavior, as well as how these data sources were utilized in this study.

The naturalistic driving study (NDS) that has been conducted as part of the SHRP2 is the largest NDS ever undertaken. Approximately 3,400 drivers from the six study sites volunteered to participate in this study in which their real-world driving behavior was recorded. Over the course of this extensive data collection, between 2010 to 2013, more than 4,300 years of naturalistic driving data were monitored and recorded. The drivers and study sites were selected such that they well represent a sample of driving behavior population, weather conditions, demographic distribution, and a variety of road types. Despite all the cautions taken in the first place, there have been studies to compare the SHRP 2 NDS sample with the national data that will be furtherly discussed in the following sections.

The first initiative to recruit participants involved random cold calling which turned to have a very low response rate of approximately 2 percent. In addition, it was found that even a smaller proportion of the respondents owned vehicles eligible for the study. The other limitation associated with this approach was the fact that study design required oversampling among older and younger drivers. However, the random cold calling did not allow to target specific age groups. Once these issues were identified, a more efficient approach was followed in which the cold calling was limited only to those households who own qualified vehicles. Also, the study sites were given the authority to pursue their own means of recruiting including social media, local newspapers, web-based Craigslist, etc. (Hankey et al., 2016).

Ultimately, over 3,300 eligible vehicles were selected for inclusion in the study. A data acquisition system (DAS) was developed to keep records of all trips made during the study period. Consequently, four video cameras, front and rear radar, accelerometer, Global Positioning System (GPS), vehicle controller area network, lane-tracking system, alcohol sensor, incident button, and data storage system were installed on all registered vehicles. Figure 3 shows the schematic view of the data acquisition system used in the data collection process. The recorded trips were collected and maintained by Virginia Tech Transportation Institute (VTTI) resulting in more than two petabytes (four million gigabytes) of data. The vehicles were equipped with forward view, in-cabin driver face view, instrument panel view, and rear-view cameras to record both the in-vehicle and out-of-vehicle environment with fine details. Figure 4

demonstrates the fields of view for each of the mounted cameras. Figure 5 shows where each of the cameras were installed, as well as the four different views that were being recorded.

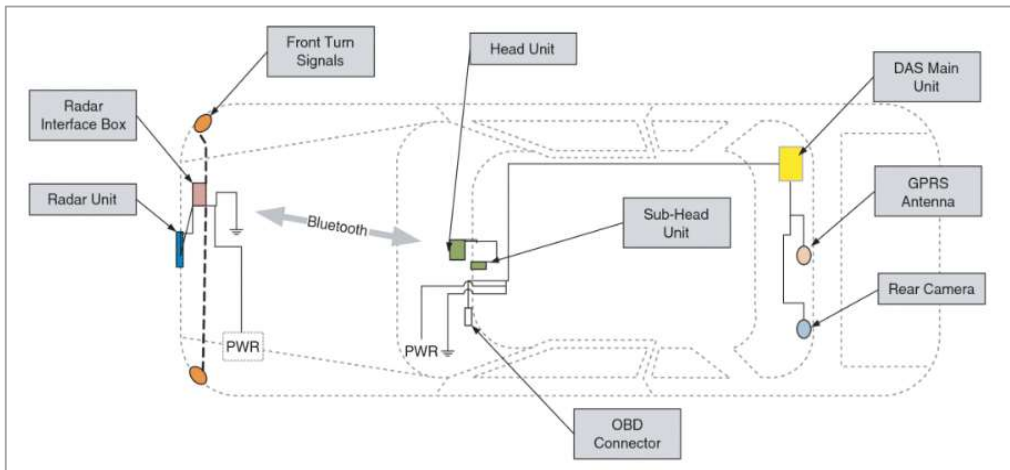

FIGURE 3 Data acquisition system schematic (Antin et al., 2015).

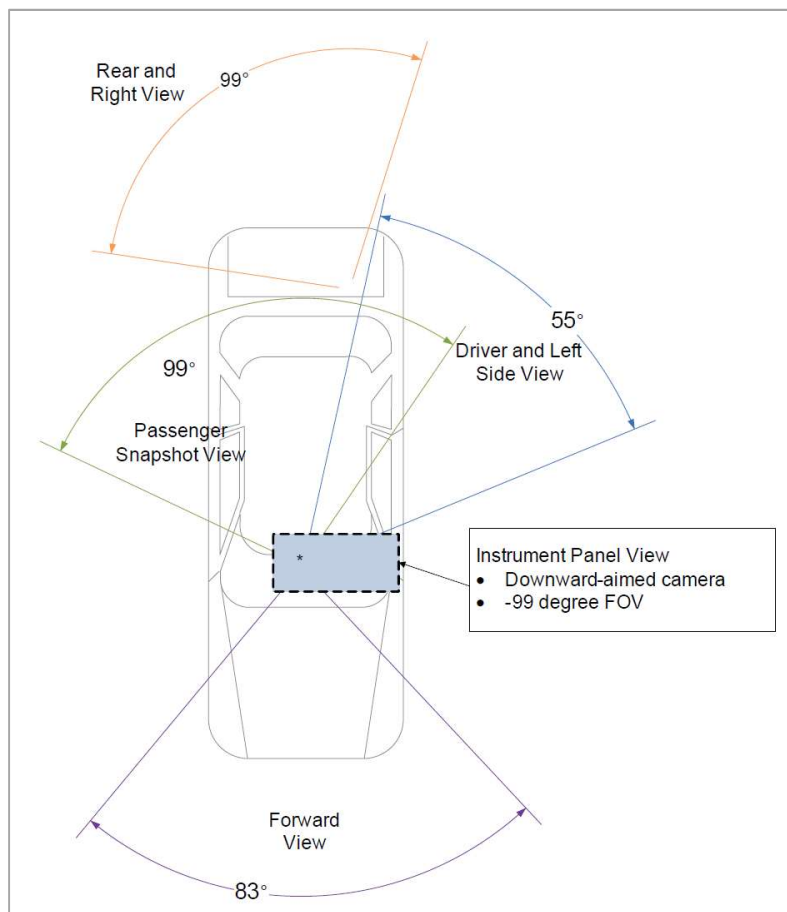

FIGURE 4 Fields of View for the data acquisition system.

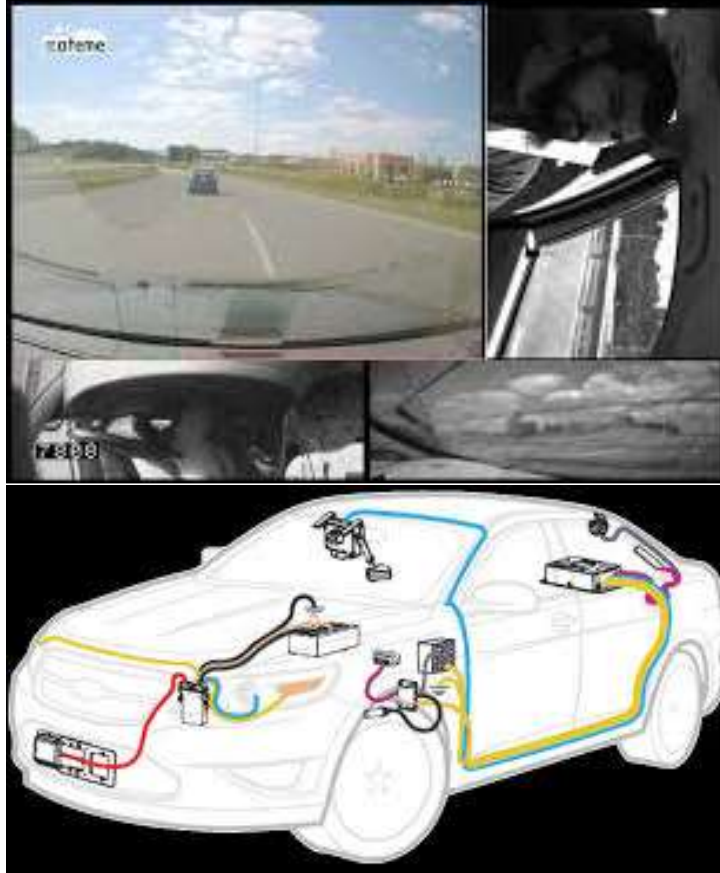

FIGURE 5 Composite snapshot of four continuous video camera views (Antin et al., 2015).

Initially, the study design involved equal number of participants across the six study sites. However, the contribution of each study site to the overall study sample turned to be different. The largest study areas were Seattle, Washington; Tampa, Florida; and Buffalo, New York with each providing roughly 20% of entire data. Following to these is Durham, North Carolina that involved collection of approximately 15% of the data, whereas State College, Pennsylvania; and Bloomington, Indiana each contributed for over 5% of the entire data (Hankey et al., 2016).

The use of the SHRP2 NDS data is critical since it deals with human subjects. This requires further consideration and obligation to ensure the secure use of personally identifying information (PII). PII is any sort of information that could potentially be used to identify human subjects in real world. This includes driver face video, GPS traces that might reveal the participant's home, work location, etc. Therefore, all the NDS participants were promised that the confidentiality of this sort of data would be maintained (Hankey et al., 2016). A certificate of confidentiality was issued by the U.S. Department of Health and Human Services (HHS) to protect the participants. Prior to participation in the study, select drivers were asked to sign an informed consent per IRB obligation. As such, the data pertaining to only those drivers who signed an informed consent could be reduced for analysis purposes. Also, a secure data enclave (SDE) was developed to restrict data access and protect the PII accordingly. An SDE is a physically isolated environment where only qualified researchers could access the PII.

Ultimately, 85% of the collected trip data were reduced and made available for research purposes. The remaining 15% were excluded for various reasons, which included trips involving an unconsented driver or missing/unusable video data, (Hankey et al., 2016). The SHRP2 NDS data may be categorized into seven different groups as follows:

1. Participant Assessments:
 - Demographic Questionnaire
 - Driving History
 - Driving Knowledge
 - Medical Conditions and Meds
 - ADHD Screening
 - Risk Perception
 - Frequency of Risky Behavior
 - Sensation Seeking Behavior
 - Sleep Habits
 - Visual, Physical, and Cognitive Test Results
 - Exit Interview
2. Vehicle Information:
 - Make, Model, Year, Body Style
 - Vehicle's Condition (Tires, Battery, etc.)
 - Safety and Entertainment Systems
3. Continuous Data:
 - Face, Forward, Rear, and Instrument Panel Video
 - Vehicle Network Data
 - Accelerometers, Gyros, Forward RADAR, GPS
 - Additional Sensor Data
4. Trip Summary Data:
 - Characterization of Trip Content
 - Start Time and Duration of Trip
 - Min, Max, Mean Sensor Data
 - Time and Distance Driven at Various Speeds, Headways
 - Vehicle Systems Usage
5. Event Data:
 - Crash, Near-Crash, Baseline
 - 30-second Events with Classification
 - Post-Crash Interviews
6. Cellphone Records:
 - Subset of Participant Drivers
 - Call Time and Duration
 - Call Type (Call, Text, Picture, etc.)
7. Roadway Data:
 - Matching Trip GPS to Roadway Database
 - Roadway Classifications
 - Other Roadway Data

In order to examine the research questions outlined previously, data were leveraged from three primary sources, including InSight, InDepth, and the Roadway Information Database (RID). The InSight and InDepth databases were developed as a part of the NDS and are maintained by the Virginia Tech Transportation Institute, whereas the RID is maintained by Iowa State University (ISU). These sources are briefly detailed here

- InSight data includes information regarding all drivers and vehicles involved in the NDS, as well as details of all trips and corresponding events (e.g., crash, near-crash, and baseline) that occurred during the study period. Each driver-vehicle pair is unique; however, these drivers and vehicles may be associated with multiple trips or events.
- InDepth contains time-series data from each trip/event, which includes GPS location information, speed, and acceleration for all NDS-involved vehicles. Location information is provided at 1-second resolution while speed and acceleration data are available at 10-Hz resolution.
- The Roadway Information Database (RID) was developed to provide support information detailing geometric and environmental characteristics across the six NDS study states. This database is comprised of roadway features and cross-sectional characteristics along 25,000 miles of roadway.

3.1 SHRP2 InSight Data

This subset of the NDS data includes the aggregated and summarized data excluding any personally identifying type of information which is also publicly available through the InSight website. The InSight data have been extracted and coded through manual review of the videos by VTTI trained interns and staff in the secured data enclave (SDE). These data have been directly captured by the DAS or were collected through surveys either before or after the study initiation.

The integration of all the collected and reduced data provide a comprehensive set of data elements for each trip included in the study sample. Unique identifiers have been developed for each event, trip, driver, and vehicle to allow for an easy integration of the datasets. A single trip may be associated with more than one event, a single vehicle may have been driven by multiple consented drivers, and some drivers might have had multiple trips and events associated with them. Further details on the statistics of the data used for each research question are provided in related sections of the report.

3.2 SHRP2 InDepth Data

As mentioned previously, the second portion of the NDS data is referred to as InDepth. This subset of data includes any information which may potentially result in identifying the participants, including time-series and video data. This information is not available online (through InSight) and access to these data requires Institutional Review Board (IRB) approval, including the development of processes and procedures related to maintenance and security of the data. This project was declared exempt under IRB ID #15-050.

The time-series data are provided by specific key identifiers for events, trips, vehicles, and drivers that may be used to integrate and/or query data. However, these identifiers are designed and coded in a way that they cannot be used to identify the drivers, their vehicle, and/or their home, work or any other of their locations in real world. The VTTI privacy constraint code indicates that time-series data may not be provided for any traversal near the beginning and the end of a trip defined as a pre-determined distance from trip origin or destination. At such locations, GPS data contain a limited random noise to further anonymize the trip. However, the VTTI tries to minimize or if possible completely eliminate such traversals when providing time-series data. In addition, any sort of face video data and unaltered forward video of a crash are regarded as PII and may be viewed only in the SDE located in Blacksburg, Virginia. However, the forward video data, used as part of this study, may be obtained and reviewed off-site contingent upon security and privacy standards.

3.3 Roadway Information Database

In conjunction with the NDS data, the roadway information database (RID) was developed as part of the SHRP2 to provide supplementary data regarding roadway geometry and traffic attributes. The RID is a geospatial database that provides detailed data for 25,000 miles of roadway across the six study states (Florida, Indiana, New York, North Carolina, Pennsylvania, and Washington). The RID is comprised of road characteristics, which were collected and combined using existing roadway data from public and private sources, as well as supplemental data collected by the ISU using a mobile van shown in Figure 6.

The RID was collected and is being maintained by the Center for Transportation Research and Education (CTRE) at Iowa State University. The effort was to collect and combine data at sites where the NDS was conducted and complement the driving data with roadway and geometry data to the extent possible. However, due to the limited resources and complications associated with the data collection process, the roadways with higher trip densities and more interesting features for research purposes were selected for data collection purposes through this project.



FIGURE 6 Mobile Van Used to Collect Data for Roadway Information Database.

Multiple data sources were leveraged to gather a comprehensive roadway database. Existing data for over 200,000 miles of roadways through related departments of transportation (DOTs) and environmental systems research institute (ESRI) were integrated with the roadway asset inventory which was collected through the instrumented mobile van driving along designated roadway stretches. The colored links in Figure 7 shows the roadway stretches on which the mobile van was driven.

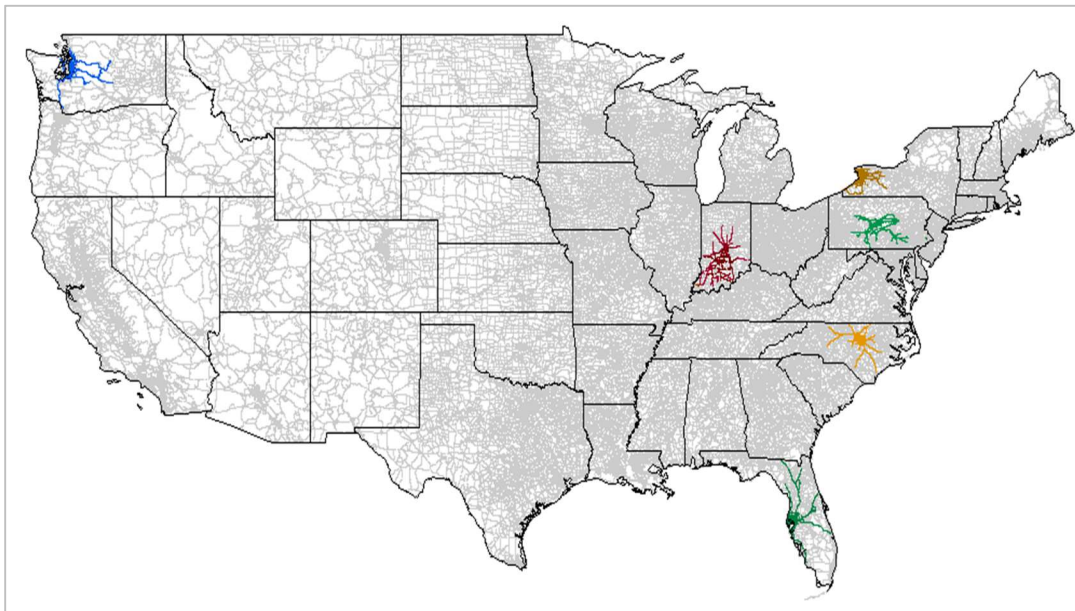

FIGURE 7 Collected links for SHRP 2 roadway information database.

The primary purpose in RID development was to provide a database that could be linked directly to the data from the NDS. The integration of the NDS data with RID provides a great opportunity to expand the available data elements to be investigated, as well as to collect more detailed information by locating traces through google earth. The RID is comprised of several shapefiles for each state as follows:

- Lighting
- Lane
- Median Strip
- Shoulder
- Rumble Strip Links
- Intersections
- Signs
- Barrier
- Location attributes
- Alignment
- Section
- Crashes

These shapefiles may be linked to one another as needed using the tools available through ArcMap based on the linear referencing system. Ultimately, a comprehensive database could be developed including required data elements across the six study sites.

3.4 Data Acquisition

Given the objectives of this extensive study, high resolution data were required from a wide range of facility types. Overall, the data utilized for this study consisted of four major categories of traces: (1) Under constant speed limit; (2) Across speed limit transition areas; (3) Along horizontal curves with speeds; and (4) Along curves without advisory speed signs as control sites. The first two included separate datasets for freeways and two-lane highways. However, the latter two were solely focused on two-lane facilities as the advisory speeds on freeways were limited to exit/entrance ramps and did not provide adequate samples of driving events for analysis purposes. Since the data integration process was similar for all four datasets, the following section describe how the datasets were constructed by integrating information from different sources. There are additional differences between the datasets design and how they were structured for analysis that will be described in later sections as necessary.

3.5 Data Integration

The research team was provided with individual comma-separated-value (i.e. csv) files for each of the requested traces. The first step was to combine all the individual csv files and create datasets to examine the research questions. To visualize the traces in ArcMap environment, and extract the geometric information from the RID, each timestamp in the time series data needed to have valid longitude and latitude information. This information was supposed to be provided at each one second interval; however, such information may be missing for some or, in some rare cases, all of the timestamps during a single trip. Consequently, only those instances with valid longitude and latitude information were retained in the dataset. This process resulted in losing parts or all of a number of trips and, as a result, subsequent analyses needed to be done by caution in such cases. Once the traces with valid geographic information were identified, they were visualized in ArcMap environment. Figure 8 displays how the obtained traces were scattered across states and were not necessarily within the boundaries of the six study areas (highlighted in aqua color). This further resulted in losing some traces as the RID only includes information across the prementioned six states. Subsequently, separate datasets were created for each state for conflation purposes as the RID is state-based.

The RID uses linear referencing system as its method of spatial referencing where the location of features is described in terms of measurements along a linear element, from a predetermined starting point. However, the obtained traces only included GPS outputs containing longitude and latitude. As a result, the first step was to convert the raw data to linear referencing system. A python script was developed to perform this task. After conversion, each point was assigned a route identifier and distance along the route that was used to extract other features from the RID.

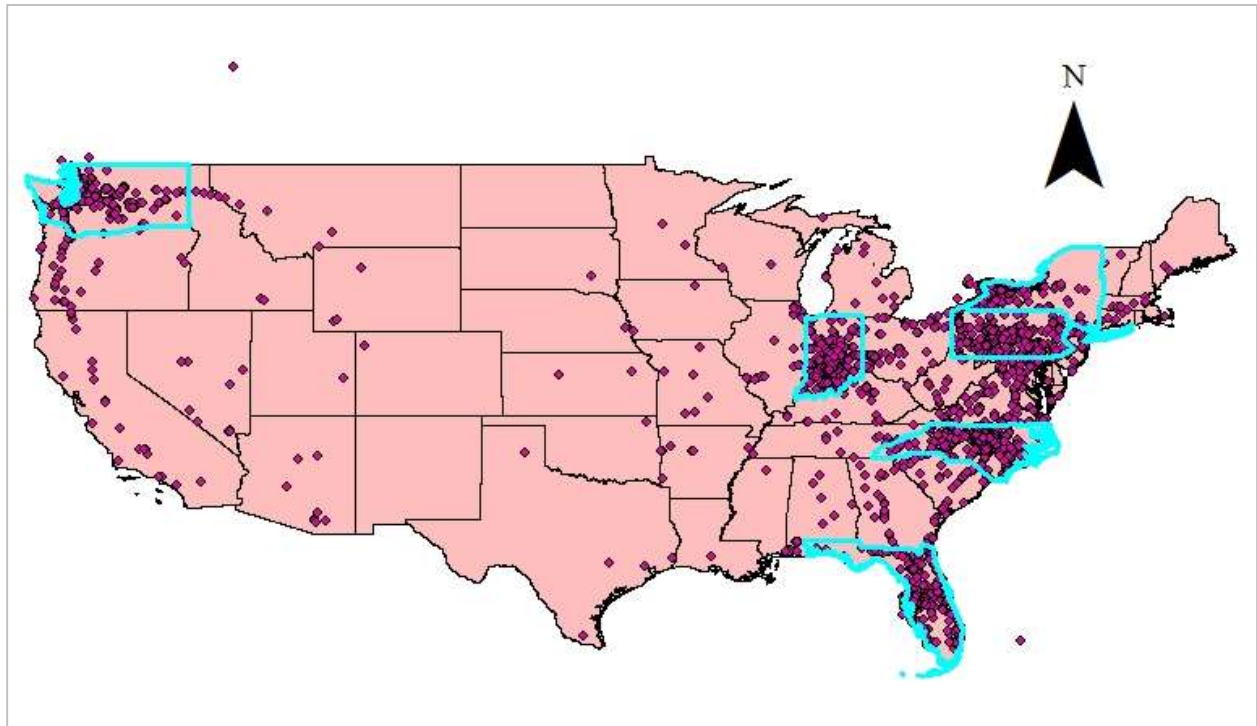

FIGURE 8 Map of the obtained traces.

Once the time-series data were converted to the appropriate referencing system, geometric features were conflated (i.e. linked) to each datum using the ArcMap tool called “Overlay Route Events”. A dynamic segmentation process was utilized, where relevant attributes were queried from each shapefile based on the route identifier and the mile point. The dynamic segmentation process is briefly described in the following steps:

1. The attribute table of the shapefile of interest was queried for those RouteIDs in the time-series data and exported as a dBase file in ArcMap. This step reduced the amount of underlying data to be read and analyzed by a significant amount, resulting in noticeable reduction in the processing time.
2. To conflate the time-series data to the shapefile of interest, the “Overlay Route Events” from linear referencing tools menu in ArcToolbox was used. The time-series dataset needed to be selected as the “Input Event Table”. Since each row in the time-series data corresponded to one point along the trip trace, the “Event Type” must be selected as “POINT”. Subsequently, “FrMeasure” has to be selected as “Measure Field”. Due to the point nature of this table, the “To-Measure-Field” is disabled.

- The dBase file exported in step 1 must be selected as the “Overlay Event Table”. Unlike the input table which was of a point type, all the tables that needed to be overlaid were in line format. Consequently, the “Event Type” must be selected as “LINE” for all these tables. In this case, both “From-Measure Field” and “To-Measure Field” needed to be specified which corresponded to the start and end points of the layer that was being overlaid. Ultimately, the output were exported and saved as a comma separated values (CSV) file. These steps are shown in Figure 9.

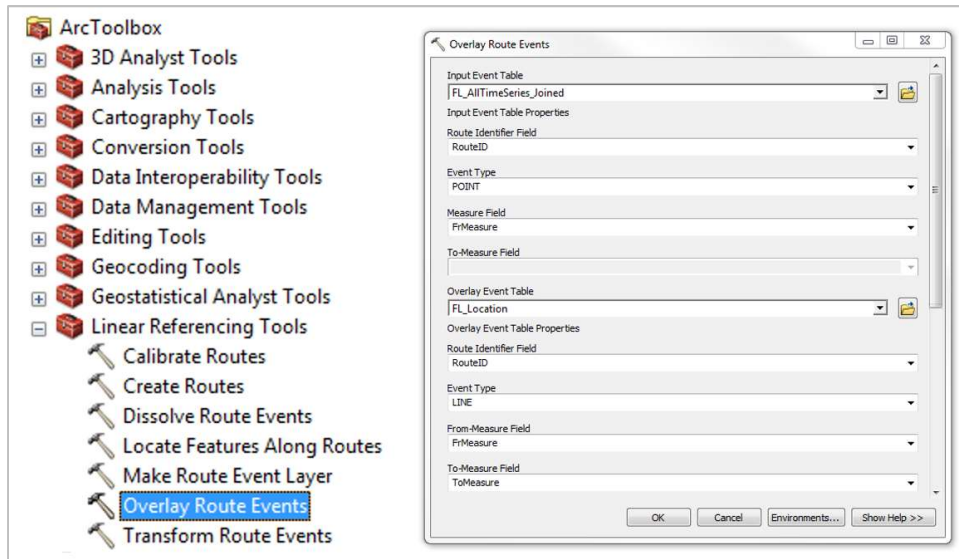

FIGURE 9 A snapshot of the conflation process.

This dynamic segmentation process was used to extract desired features from various RID shapefiles. Table 1 provides a list of shapefiles and the features extracted from the RID as part of this study. The information for each point along the event traces was extracted from the proper record with identical Route ID, and a From- and To- Measure which made up a segment embracing the queried point. Blank fields were displayed if no record matched these conditions.

TABLE 1. RID Shapefiles and the Associated Extracted Information

Shape file	Information	Polynomial	Point
Alignment	Curve Radius - Curve Direction - Superelevation	X	
Location	Grade - Cross Slope	X	
Lane	Number of Lanes by Type – Lane Width	X	
Median	Median Type	X	
Shoulder	Shoulder Type – Shoulder Width	X	
Barrier	Barrier Type	X	
Rumble Strip	Location (Edge Line vs. Shoulder vs. Centerline)	X	
Sign	MUTCD Code- Message		X

In contrast to the other shapefiles in RID, the speed limit and advisory speed data (i.e. all sign-related information) were in point format. Since the time-series data were also in point format, it was not possible to follow similar procedure detailed above to extract this type of data from the RID. To be able to do the conflation process, at least one of the two tables must be of line type. Therefore, to extract the speed limit data, polynomial shapefiles were developed from the sign inventory. To derive the information as to speed limit at each point, the “signs” shapefile from the RID was queried to identify those that represent the statutory speed limit information. MUTCD sign type R2-1 corresponds to the regulatory speed limit signs and was used to query the shapefile. The output from this query included location information (RouteID and mile point), as well as the associated sign message (i.e., the posted speed limit). Speed limits were assumed consistent between two consecutive signs, meaning that the begin mile-point for each sign was the end mile-point for the previous sign. Consequently, using this line-based dBase, speed limit information was extracted following the conflation process outlined previously. While the outlined approach performed relatively well on conflating RID features to obtained trip traces, there were some issues that needed closer investigation and are detailed here:

- **Conflation Errors:** Adjacency to other roadways may result in some conflation issues. During the data collection process by the mobile van, the collected data were assigned to the closest roadway, thus in some cases there may be multiple conflated information to a road segment.
- **Lack of Directional Data on Undivided Roadways:** In the RID, divided roadways were assigned two different RouteIDs to account for each direction of travel lanes. However, this was not the case for undivided roadways, meaning that only one RouteID was specified for either of directions. Consequently, conflation of the attributes corresponding to the opposing direction was likely. This required further investigation of the resulting tables to match the coded attributes for the same side of the roadway centerline. Figure 10 displays a flow chart for the logic used to eliminate the irrelevant features extracted in the conflation process.

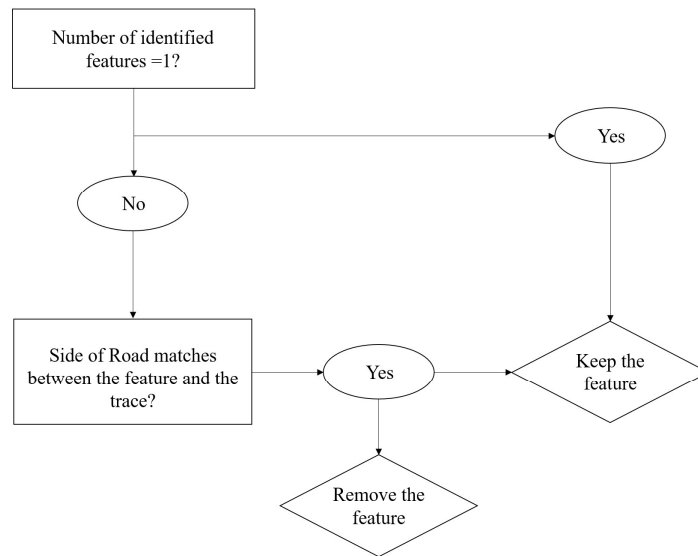

FIGURE 10 Flow chart of the logic used to resolve the conflation issues.

Once these issues were resolved, comprehensive datasets including time-series data, geometric features from RID, and InSight supplementary data were created. Further details as to how the raw data were queried and requested, as well as dataset structures are discussed in the following sections that detail specific investigations.

4.0 SPEED SELECTION UNDER CONSTANT SPEED LIMITS

The first research question investigated as part of this study involved examining speed profiles under constant posted speed limit. While the segments over which the speed profiles were analyzed included a wide variety of geometric characteristics and environmental conditions, they were not associated with multiple speed limits or advisory speed signs. Due to essential differences in the nature of freeways and two-lane highways, the speed profiles were examined separately for each of these facilities. The SHRP 2 InSight data included an extensive inventory of driving traces across all six states. To provide researchers with an opportunity to be able to analyze various scenarios, these reduced data were comprised of baseline events (i.e. normal driving events), as well as crash, near-crash, and other types of conflicts. Speed profiles were analyzed for near-crash and baseline events to examine how drivers select their travel speed under various roadway and environmental conditions.

4.1 Data Summary

Data were obtained for all crash, near-crash, and baseline events that had been reduced by the VTTI as of April 2016 for both freeways and two-lane highways across the six study states. The facility type was determined using the “Locality” field in the InSight event table. Events with locality type of “interstate/bypass/divided highway with no traffic signals” were selected as likely freeway events. On the other hand, events for which the locality field was marked as “bypass/divided highway with traffic signal” were identified as likely subjects to represent two-lane highways. Consequently, the InSight data including events, trips, participants, and vehicle tables, as well as the InDepth data including the location, speed, and lateral acceleration/deceleration data were obtained for every candidate event. This resulted in a total of 9,508 and 7,495 potential events for freeways and two-lane highways, respectively. However, as the locality field from InSight is not necessarily reflective of where the event occurred, an extensive quality control process was conducted for all events using the RID attributes and Google Earth. Different criteria including maximum speed limit, number of lanes, and presence of intersections along segments were used to categorize the data into potential freeways and two-lane segments. One other factor that resulted in losing traces was improper GPS information or missing RID attributes, specifically posted speed limit which was the main focus of this study. Consequently, these resulted in significant reduction in the sample size yet providing sufficient data to examine the proposed research questions. Ultimately, a total of 4,909 and 2,898 events were identified on freeways and two-lane highways, respectively.

The data used in this section were comprised of a series of 20-second snapshots of driving traces across all six study sites. The raw data provided by the VTTI included 20-second snapshots of trips for baseline events, whereas this extended to 30 seconds for safety critical events including 20 seconds preceding the crash/near-crash start and 10 seconds following that. However, since the focus of this analysis was to investigate general drivers’ speed selection behavior, only the first 20 seconds of such incidents were included in the analysis. These 20-second snapshots were verified through a manual review to confirm they did not include the duration over which speeds were impacted by the incident. When involved in a crash or near-crash, there are myriads of other factors besides driver behavior that impact travel speed where abrupt breaking and marked speed variability occur. Unlike traditional data collection methods in which the exact start of the

crash or near-crash event was not evident, naturalistic driving study data allowed for accurate identification of time and location of crash/near-crash incidence.

The same general procedure was utilized to develop each analysis dataset, which is briefly detailed here. The InDepth data provide longitude and latitude information on one-second intervals. Since the RID utilizes a linear referencing system (LRS), the first step to extract geometric information was to convert the InDepth coordinate information to the LRS. Consequently, geometric information, as well as cross-sectional characteristics corresponding to each trace was derived from the RID through eight shapefiles. This included information on: horizontal and vertical alignment; cross-slope; number, type, and width of travel lanes; type of median and shoulder; presence and type of barrier, rumble strips, and traffic signs; among others.

Most of these shapefiles are of a segment nature, except for the sign shapefile, which is a point-based layer. This file was primarily used to obtain speed limit information, which was critical for the purposes of this study. Consequently, a segment-based speed limit file was developed based on the assumption that the speed limit is consistent between consecutive signs in each direction, meaning that the begin mile-point for each sign was the end mile-point for the previous sign.

The conflation process was conducted through the GIS by overlaying the acquired traces with each of the shapefiles. However, in some cases deriving geometric features was not possible due to missing GPS coordinates across all/parts of individual trips. Ultimately, all the extracted RID features were integrated with InSight tables (i.e. event details, trip information, vehicle features, and driver attributes) to achieve comprehensive datasets to examine the research questions.

Figure 11 displays examples of one near-crash and one baseline incident across a segment posted at 70-mph. There is no sign of abrupt change over this duration of the near-crash. However, the speed profile displayed an evident sharp reduction later at around second 22, probably due to the driver reaction to the occurrence of the near-crash, which was not included in the analysis set. In all such cases, this pattern starts after the 20th second, and the speed seems stable prior. This was not only verified through visualization, but also by examining a field in the InSight data that indicated the timestamp the driver was believed to first notice the threat. As a result, these 20 second snapshots were selected as surrogates of drivers' choice of speed under constant speed limit across freeways and two-lane highways.

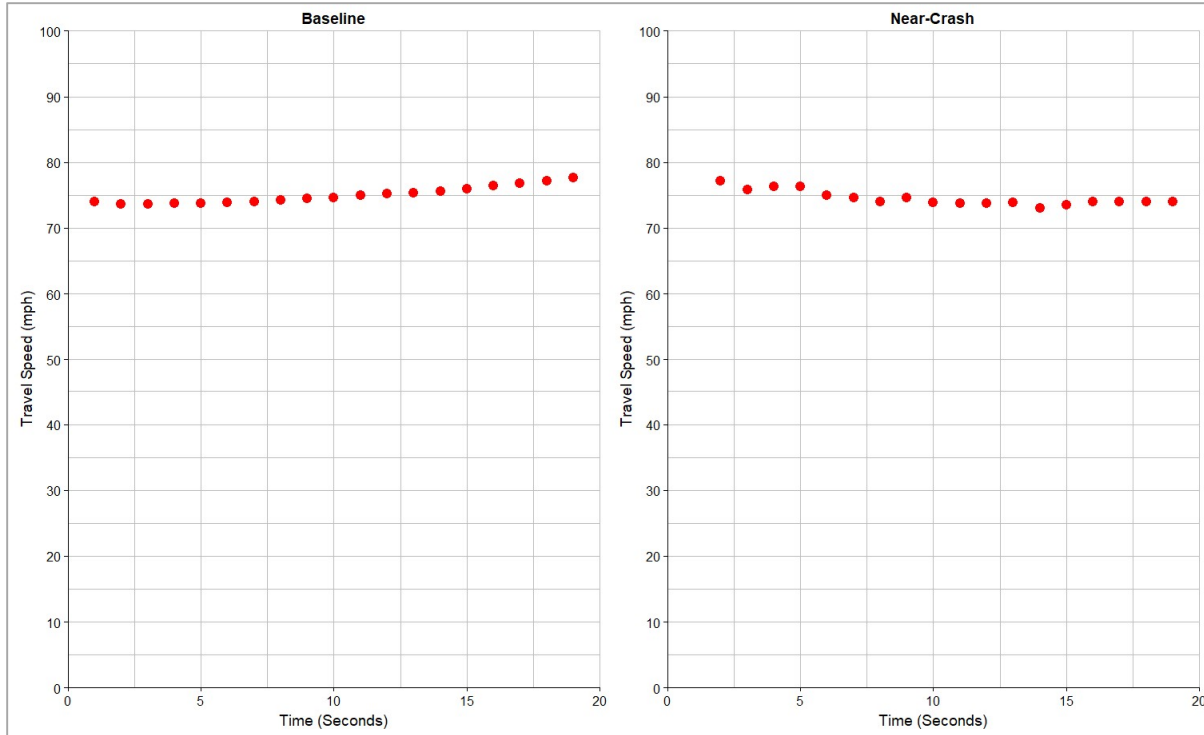

FIGURE 11 Example Speed Profiles of a Baseline and a Near-Crash Posted at 70 mph.

Once all the data were integrated and reduced, a comprehensive dataset including a total of 4,375 driving traces at four different posted speed limits ranging from 55-mph to 70-mph was created for freeways. The mean speed, as well as the speed standard deviation were calculated over the 20-second duration of the travel for each trace. Figure 12 displays the boxplots for the mean travel speed at each speed limit. This indicates that as the posted speed limit increases so does the mean travel speed. However, such increases do not seem to emerge with a fixed stepped pattern as the mean speeds at 55- and 60-mph, as well as those at 65- and 70-mph fall closer to one another.

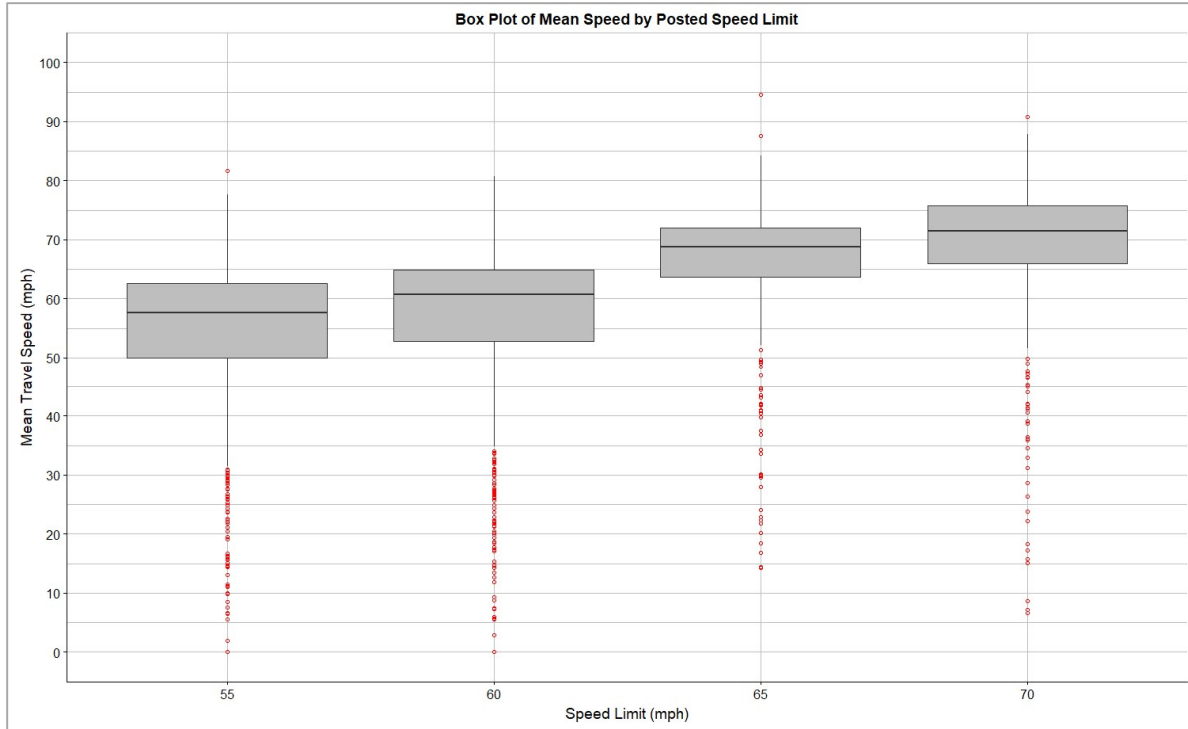

FIGURE 12 Box Plots of Mean Travel Speed by Posted Speed Limit on Freeways.

In addition, research studies have generally shown the travel speed to be inversely impacted by traffic density (McLaughlin and Hankey 2015). The InSight data included a variable indicating the traffic density at time of travel and was used to investigate such impact in this study. This parameter defines traffic density based upon the level of service (LOS) measure, which is a qualitative measure that characterizes a roadway’s operational performance in consideration of highway users’ perceptions. To visually assess the impact of traffic density on mean speeds, boxplots were generated at combinations of speed limit and level-of-service and are presented in Figure 13. As expected the travel speed was shown to be adversely impacted by poor LOS. However, the speeds were shown to be more stable at LOS A through C, while significant reductions are evident when reaching LOS D and beyond.

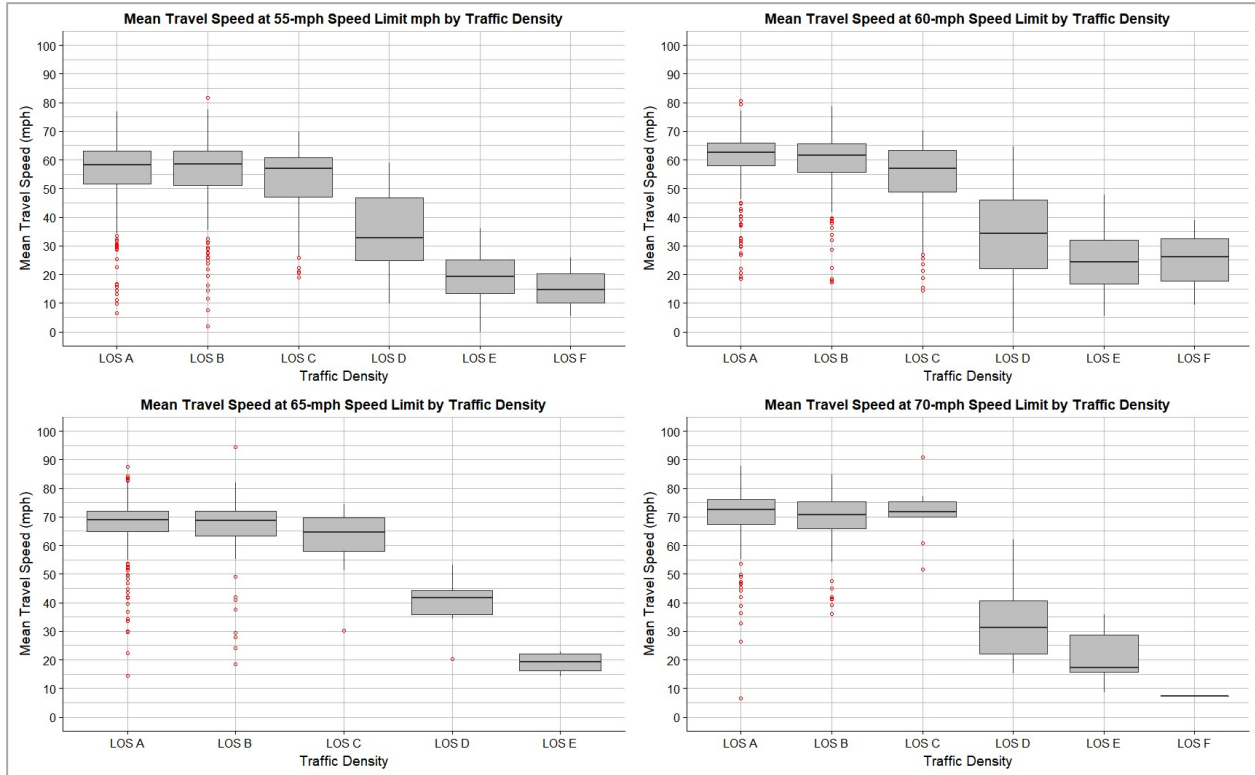

FIGURE 13 Boxplots of Mean Speed by Posted Speed Limit and Traffic Density on Freeways.

As alluded to previously, a comprehensive dataset including variables describing roadway geometry, driver behavior, vehicle characteristics, and speed profiles was put together for each of the samples. To simplify the modeling steps and the subsequent discussion of results, a series of indicator variables were introduced for different categories of variables. Table 2 provides the summary statistics of the analyzed data where the mean value, as well as the standard deviation are presented for each variable. In case of binary indicators, the mean value is reflective of the percentage of sample possessing such characteristic.

The summary statistics indicate that the dataset was relatively balanced considering the posted speed limit with the majority of traces belonging to 55- and 60-mph segments. However, this was not the case with traffic density where less than one percent of traces occurred at LOS F. Also, the data included information as to driver’s age and gender. The sample was balanced with respect to gender. On the other hand, the younger and older drivers were oversampled when recruiting participants for the naturalistic driving study (Antin et al. 2015) and such pattern was evident in this dataset, as well. Ultimately, these data were used to develop regression models to investigate driver’s choice of speed under different conditions and are furtherly discussed in later sections.

TABLE 2. Summary Statistics of Freeway Traces Under Constant Speed Limit

Variable	Minimum	Maximum	Mean	Std. Dev.
55-mph Limit	0	1	0.33	0.47
60-mph Limit	0	1	0.32	0.47
65-mph Limit	0	1	0.21	0.41
70-mph Limit	0	1	0.14	0.35
LOS A	0	1	0.53	0.50
LOS B	0	1	0.34	0.47
LOS C	0	1	0.08	0.27
LOS D	0	1	0.04	0.18
LOS E	0	1	0.02	0.12
LOS F	0	1	<0.01	0.06
Clear Weather	0	1	0.91	0.28
Rain	0	1	0.08	0.28
Snow/Sleet	0	1	0.00	0.07
Non-Workzone	0	1	0.96	0.19
Workzone	0	1	0.04	0.19
Non-Junction	0	1	0.63	0.48
Junction	0	1	0.37	0.48
Upgrade	0	1	0.10	0.30
Downgrade	0	1	0.05	0.22
Female Driver	0	1	0.51	0.50
Male Driver	0	1	0.49	0.50
Driver Age: 16-24	0	1	0.38	0.49
Driver Age: 25-59	0	1	0.41	0.49
Driver Age:60 or above	0	1	0.21	0.41

A similar dataset was created including 2,901 traces occurred on two-lane highways under constant speed limit. This dataset included a variety of posted limits ranging from 25 mph to 60 mph depending on the state and area type (i.e. urban vs. rural). Figure 14 presents boxplots of the mean travel speed by posted speed limit. The pattern is similar to what was observed for freeways where the travel speed and posted speed limit were directly correlated. However, the interquartile ranges were found to be wider for two-lane highways which is indicative of more diverse speed choices on these facilities as compared to freeways. In addition, the difference in mean speeds between two consecutive limit seems to be decreasing when reaching higher posted limits.

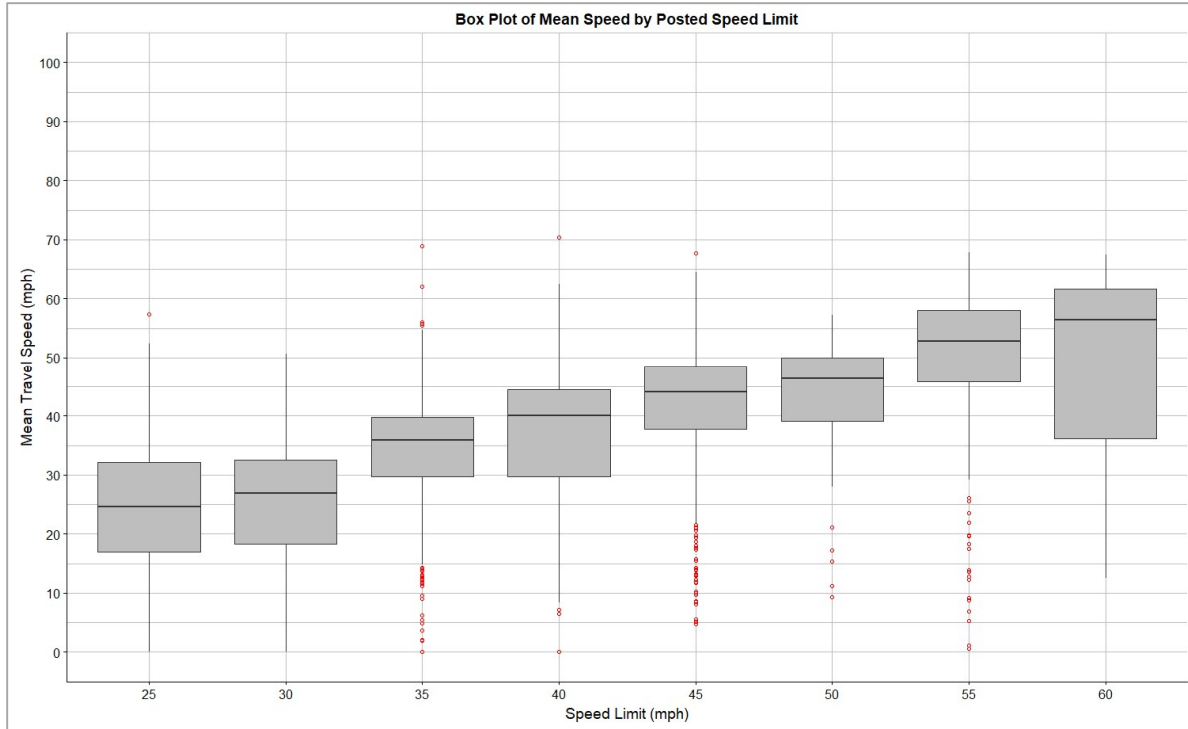

FIGURE 14 Box Plot of Mean Travel Speed by Posted Speed Limit on Two-Lane Highways.

In addition, the impact of traffic density on mean speeds was investigated through boxplots presented in Figure 15. It is imperative to note that unlike freeways, these traces did not cover all LOSs due to lower AADTs and the fact that they occurred in less urban areas. Such pattern was more evident at higher speed limits. For example, the traces under the 60-mph limit corresponded to only LOS-A and LOS-B, whereas more variation in traffic density was observed at lower limits.

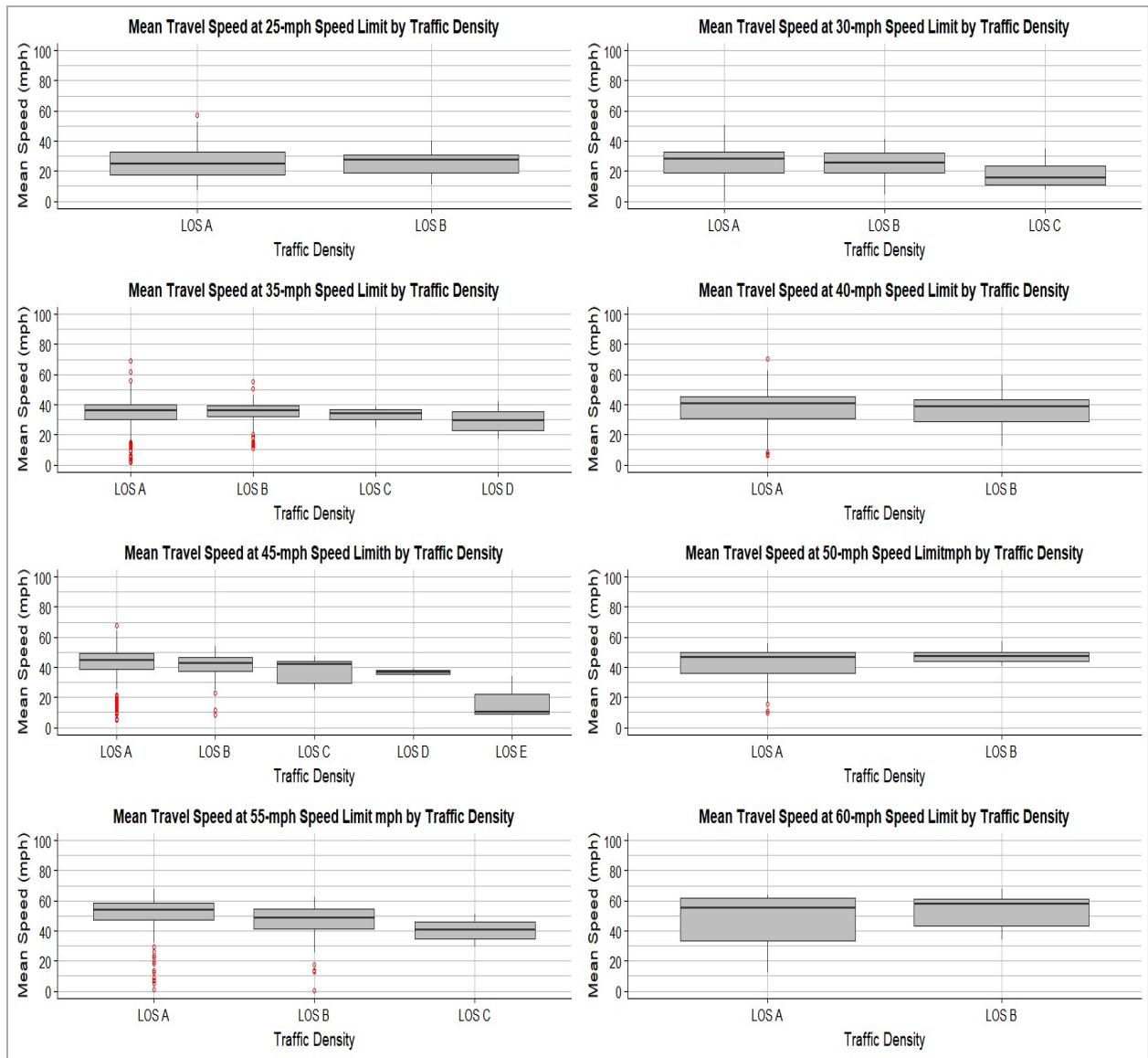

FIGURE 15 Boxplots of Mean Speed by Posted Speed Limit and Traffic Density on Two-Lane Highways.

Like freeways, a series of binary indicators were introduced to represent various categories of variables included in the dataset. The descriptive statistics for a subset of variables is presented in Table 3. When looking at the speed limit indicators, one important point is the smaller percentages for 25-, 40-, 50-, and 60-mph limits compared to other limits. Also, the majority of traces occurred under LOS-A and LOS-B resulting in less than two percent of the sample having LOS-C or below. One other characteristic specific to two-lane highways is presence of various kinds of access points along segments. This includes, but is not limited to, intersections, driveways, and on-street parking; however, since all other types access points had very few frequencies, they were not included as separate categories in the analysis set.

TABLE 3. Summary Statistics of Two-Lane Traces Under Constant Speed Limit

Variable	Minimum	Maximum	Mean	Std. Dev.
25-mph Limit	0	1	0.05	0.22
30-mph Limit	0	1	0.19	0.39
35-mph Limit	0	1	0.21	0.41
40-mph Limit	0	1	0.09	0.29
45-mph Limit	0	1	0.23	0.42
50-mph Limit	0	1	0.03	0.16
55-mph Limit	0	1	0.18	0.38
60-mph Limit	0	1	0.02	0.14
LOS A	0	1	0.77	0.42
LOS B	0	1	0.21	0.41
LOS C	0	1	0.01	0.12
LOS D	0	1	<0.01	0.05
LOS E	0	1	<0.01	0.06
LOS F	0	1	<0.01	0.02
Clear Weather	0	1	0.92	0.27
Rain	0	1	0.07	0.26
Snow/Sleet	0	1	0.01	0.09
Non-Workzone	0	1	0.99	0.12
Workzone	0	1	0.01	0.12
Intersection	0	1	0.09	0.29
Driveway	0	1	0.16	0.37
Parking	0	1	0.08	0.27
Upgrade	0	1	0.10	0.30
Downgrade	0	1	0.05	0.21
Male	0	1	0.49	0.50
Female	0	1	0.51	0.50
Age 16-24	0	1	0.36	0.48
Age 25-59	0	1	0.36	0.48
Age > 59	0	1	0.28	0.45

4.2 Statistical Methods

After the data were assembled, three general questions of interest were first investigated:

1. How did speed limit and other roadway, driver, vehicle, and environmental factors affect the mean vehicle speed during each of the events?
2. How did speed limit and other factors affect the standard deviation of speeds for drivers/vehicles during each event?
3. How did speed limit, mean speed, and standard deviation in speeds affect the risk of crash/near-crash events while controlling for other pertinent factors?

These questions were the focus of separate preliminary analyses for both freeways and two-lane highways. For each facility type, a series of mixed-effect linear regression models were estimated. Mean speed and the standard deviation in speed over the first 20 seconds of each event was computed for the purpose of model estimation. The regression equations for each of these performances measure take the following form:

$$ms_i = \beta_{i,ms}X_{ms} + \varepsilon_{i,ms} \quad (\text{Eq. 1})$$

$$sd_i = \beta_{i,sd}X_{sd} + \varepsilon_{i,sd} \quad (\text{Eq. 2})$$

where: ms_i is the mean speed (in mph) during event i ; sd_i is the calculated standard deviation of speeds during event i (in mph); X is a vector of speed limit, traffic, and roadway characteristics; β 's are vectors of estimable parameters; and ε 's are disturbance terms capturing unobserved characteristics normally distributed with mean zero and variance of σ^2 .

One concern that arises within the context of this study is the anticipated correlation in speed selection behavior among the same individuals. From an analytical standpoint, it is important to account for the fact that specific drivers may tend to driver faster (or slower) than others (i.e., their general travel speeds are correlated across events). Failing to account for such correlation would underestimate the variability in travel speeds and potentially lead to biased estimates for the impacts of specific factors, such as the speed limit or geometric characteristics.

Consequently, a participant-specific intercept term, δ_j , was introduced to account for the fact that specific drivers may tend to drive faster (or slower) than others due to factors that were not captured by the information from the NDS or RID. These may include differences in driving styles, risk perception, or other factors that affect speed selection. This participant-specific term retained the same coefficient for each driver in every event (assuming the driver has multiple events in the database) and, thus, was able to capture general differences in speed selection behavior. This additional term was assumed to be normally distributed with mean of zero and variance of σ^2 ; Consequently, the previous equations take the following forms:

$$ms_{ij} = \beta_{i,ms}X_{ms} + \varepsilon_{i,ms} + \delta_{j,ms} \quad (\text{Eq. 3})$$

$$sd_{ij} = \beta_{i,sd}X_{sd} + \varepsilon_{i,sd} + \delta_{j,sd} \quad (\text{Eq. 4})$$

where δ_j is an intercept term specific to driver j ; this is what is generally referred to as mixed-effect linear regression model. This section presents the results of these analyses and provides a discussion of the implications of these findings.

4.3 Results and Discussion

Table 4 and Table 5 provide results of the analyses for mean travel speed and standard deviation in travel speeds on freeways. For these facilities, a total of 4,375 events corresponding to 1,975 unique drivers were analyzed. To gain a better understanding as to driver speed selection, separate models are provided for the overall sample, as well as a subset of events that occurred under level-of-service A. The reason for that is the fact that under traffic congestion, some parameters other than roadway geometry and drivers' characteristics may influence drivers'

choice of speed. This includes but is not limited to travel speed of those vehicles surrounding the subject vehicle.

TABLE 4. Mixed Effect Linear Regression Model for Mean Speed on Freeways

Total Sample			LOS-A Only Sample			
Random Effects:						
Groups	Variance	Std. Dev.		Variance	Std. Dev.	
Participant ID	17.920	4.233		19.350	4.399	
Residual	82.050	9.058		60.270	7.763	
Fixed Effects:						
Model Term	Coeff.	Std. Err.	t-stat	Coeff.	Std. Err.	t-stat
Intercept	69.343	0.537	129.028	69.847	0.587	118.943
55-mph limit	-13.176	0.498	-26.443	-13.605	0.574	-23.708
60-mph limit	-9.766	0.518	-18.851	-9.163	0.612	-14.979
65-mph limit	-3.335	0.541	-6.168	-3.530	0.594	-5.939
70-mph limit	Baseline			Baseline		
LOS A	Baseline			-		
LOS B	-1.479	0.331	-4.473	-		
LOS C	-8.455	0.577	-14.644	-		
LOS D	-27.004	0.823	-32.826	-		
LOS E	-40.907	1.194	-34.275	-		
LOS F	-46.167	2.590	-17.823	-		
Non-junction	Baseline			Baseline		
Junction	-1.758	0.312	-5.637	-2.578	0.392	-6.578
Non-work zone	Baseline					
Work zone	-3.606	0.776	-4.648	-3.219	1.096	-2.937
Clear weather	Baseline			Baseline		
Rain	-2.222	0.536	-4.146	-2.403	0.696	-3.452
Snow or sleet	-12.336	2.205	-5.596	-13.094	2.439	-5.368
Age 16 to 24	3.795	0.465	8.162	3.589	0.528	6.804
Age 25 to 59	2.479	0.467	5.306	2.340	0.535	4.372
Age 60 or above	Baseline			Baseline		
Null Log-Likelihood		-17,760			-8,794	
Log-Likelihood		-16,213			-8,333	
Null AIC		35,416			17,592	
AIC		32,460			16,690	
Null BIC		35,429			17,603	
BIC		32,568			16,759	
Number of Observations: 4,375			Number of Observations: 2,320			
Number of Participants: 1,975			Number of Participants: 1,432			

Starting with the entire sample, the average speed on freeways with a 70-mph posted limit was found to be 69.3 mph. Speeds were approximately 3.3 mph lower on freeways posted at 65 mph (mean of 66.0 mph). More pronounced decreases occurred on the lower speed freeways as the mean speeds were 56.1 and 59.5 mph where speed limits were 55 and 60 mph, respectively. This is consistent with prior research showing that speed limit increases result in changes in the observed mean and 85th percentile speeds that are less pronounced than the actual speed limit increases (Lynn and Jernigan, 1992; Ossiander and Cummings, 2002; Freedman and Esterlitz, 1990; Parker, 1997; Kockelman et al., 2006; Davis et al., 2015; Hu, 2017; Johnson and Murray, 2010).

Beyond speed limits, mean speeds were also largely affected by the level of traffic congestion present at the time of the event. Speeds were relatively stable across levels-of-service A and B, but began to drop significantly under LOS C and, particularly, at LOS D, E, and F. As shown by various prior studies (Emmerson, 1969; McLean, 1981; Glennon et al., 1983; Lamm and Choueiri, 1987; Kanellaidis et al., 1990) speed selection was also highly dependent upon the roadway environment as speeds decreased significantly in work zones (3.6 mph) and under adverse weather conditions (2.2 mph in rainy and 12.3 mph in snowy weather).

As far as drivers' characteristics, travel speeds were shown to be considerably higher among younger and middle-aged drivers. The mean speeds were found to be approximately 3.8 mph greater for those age under 24, whereas this effect is reduced to 2.5 mph when considering drivers between 25 and 59, compared to elderly drivers. All parameters included in the model were statistically significant under a 95-percent confidence interval (i.e. t-value greater than 1.96).

The results are generally consistent for those events that occurred under free-flow conditions (i.e., LOS A), although a few notable differences were found. When considering only those events occurring during LOS A, slight differences were observed across all four speed limit categories. Mean speeds were roughly 0.5 mph greater across the four speed limits when considering those events under LOS A as compared to those of the entire sample. Also, the events under free flow condition were shown to be more impacted by presence of roadway junctions (i.e. interchanges) which is probably due to the unexpected interruptions resulting from weaving movements. The impact of adverse weather condition, as well as drivers' age were found to be consistent between the two models.

Table 5 includes the results of the random effect model developed for speed standard deviation across freeways. As shown by prior research in this area (Emmerson 1969), speeds tended to become more consistent (i.e., lower variability) as speed limits increased. The results indicated no statistically significant difference in speed variability between events under 70- and 65-mph limits. A recent Michigan study has shown similar results (Gates et al. 2015), with speeds being significantly more variable on 55-mph urban freeways, suggesting these findings are transferable across states. As expected, the variability in travel speeds was predominantly affected by the level of congestion. The standard deviation was lowest under LOS A and highest under LOS E, where an approximate difference of 2 mph was observed. Speeds were also highly variable within work zone environments and across interchange areas.

TABLE 5. Mixed Effect Linear Regression Model for Speed Standard Deviation on Freeways

Random Effects:			
Groups	Variance	Std. Dev.	
Participant ID	0.274	0.523	
Residual	4.142	2.035	
Fixed Effects:			
Model Term	Coeff.	Std. Err.	t-stat
Intercept	0.987	0.063	15.775
55-mph limit	0.864	0.079	10.959
60-mph limit	0.364	0.084	4.345
65-mph limit	Baseline		
70-mph limit	Baseline		
LOS A	Baseline		
LOS B	0.412	0.071	5.823
LOS C	1.237	0.124	9.992
LOS D	2.183	0.177	12.349
LOS E	2.344	0.258	9.085
LOS F	1.173	0.561	2.090
Non-junction	Baseline		
Junction	0.484	0.067	7.254
Non-work zone	Baseline		
Work zone	0.360	0.166	2.175
Null Log-Likelihood		-9722	
Log-Likelihood		-9448	
Null AIC		19448	
AIC		18919	
Null BIC		19461	
BIC		18996	
Number of Observations: 4,375			
Number of Participants: 1,975			

Turning to two-lane highways, many of the same factors were found to influence driver speed selection. Table 6 and Table 7 provide results of similar analyses conducted on two-lane highways. On these facilities, mean speeds were generally near the posted limit under low-speed conditions, but tended to decrease below the posted limit at higher speeds. For example, the mean speed was around 26.2 mph and 34.6 mph at 25- and 35-mph limits, respectively. However, starting from 40-mph limit, travel speeds started to drop below the posted limit. No significant differences were observed between the segments posted at 55 and 60 mph where mean speeds turned out to be much lower than the posted limit (nearly 50 mph). This is largely reflective of the larger number of urban highways included in the NDS sample, where speeds are significantly lower as compared to more rural facilities.

TABLE 6. Mixed Effect Linear Regression Model for Mean Speed on Two-Lane Highways

	Total Sample			LOS A Only		
Random Effects:						
Groups	Variance	Std. Dev.		Variance	Std. Dev.	
Participant ID	7.470	2.733		13.090	3.618	
Residual	80.380	8.966		78.030	8.833	
Fixed Effects:						
Model Term	Coeff.	Std. Err.	t-stat	Coeff.	Std. Err.	t-stat
Intercept	49.314	0.502	98.332	49.801	0.564	88.263
25-mph limit	-23.114	0.872	-26.516	-23.213	0.970	-23.937
30-mph limit	-21.551	0.585	-36.862	-21.514	0.676	-31.846
35-mph limit	-14.727	0.557	-26.454	-14.916	0.635	-23.488
40-mph limit	-11.242	0.705	-15.949	-11.538	0.795	-14.505
45-mph limit	-7.811	0.544	-14.367	-8.130	0.619	-13.127
50-mph limit	-4.864	1.133	-4.292	-5.769	1.375	-4.195
55/60-mph limit	Baseline			Baseline		
LOS A	Baseline			N/A		
LOS B	-1.362	0.434	-3.135	N/A		
LOS C	-6.245	1.450	-4.307	N/A		
LOS D	-11.307	3.322	-3.404	N/A		
LOS E	-23.639	3.135	-7.541	N/A		
LOS F	-			N/A		
No access points	Baseline			Baseline		
Driveway	-0.874	0.486	-1.798	-1.195	0.558	-2.141
Intersection	-2.339	0.616	-1.798	-1.728	0.736	-2.349
On-street parking	-4.413	0.616	-3.797	-5.032	0.731	-6.887
Non-work zone	Baseline			Baseline		
Work zone	-3.783	1.481	-2.555	-6.405	1.877	-3.412
Degree of Curvature	-0.013	0.005	-2.746	-0.011	0.005	-2.107
Clear/rainy weather	Baseline			Baseline		
Snow or Sleet	-7.588	2.006	-3.782	-8.771	2.302	-3.811
Age 16 to 24	1.924	0.469	4.107	1.418	0.544	2.608
Age 25 to 59	1.118	0.469	2.382	0.665	0.544	1.221
Age 60 or above	Baseline			Baseline		
Null Log-Likelihood			-11464			-8835
Log-Likelihood			-10600			-8196
Null AIC			22932			17673
AIC			21242			16425
Null BIC			22944			17685
BIC			21368			16552
Number of Observations: 2,901						
Number of Participants: 1,593						

As with freeways, traffic congestion was a primary determinant of travel speeds, reducing mean speeds by as much as 23.7 mph at LOS E. Similarly, speeds were shown to be relatively consistent across LOS A and B and began to drop markedly starting from LOS C. Unlike freeways, no event occurred under LOS F. Speeds were also significantly reduced in the vicinity of access points including driveways and intersections, as well as in presence of on-street parking. Among these, on-street parking had the highest impact with approximately 4.5 mph reduction in travel speeds. However, this effect is much lower near driveways and intersections where mean speeds dropped by 0.9 and 2.3 mph, respectively. Similarly, marked reductions were observed across workzones and under snowy weather condition. However, the results indicated no differences between clear and rainy weather condition which could be attributed to the general lower speeds on two-lane highways as compared to freeways.

TABLE 7. Mixed Effect Linear Regression Model for Speed Standard Deviation on Two-Lane Highways

Random Effects:			
Groups	Variance	Std. Dev.	
Participant ID	7.470	2.733	
Residual	80.380	8.966	
Fixed Effects:			
Model Term	Coeff.	Std. Err.	t-stat
Intercept	2.476	0.117	21.193
25-mph limit	1.061	0.267	3.969
30-mph limit	1.184	0.173	6.835
35-mph limit	0.809	0.167	4.855
40-mph limit	1.007	0.214	4.705
45-mph limit	0.51	0.163	3.127
50-mph limit	Baseline		
55/60-mph limit	Baseline		
LOS A	Baseline		
LOS B	Baseline		
LOS C or Below	0.894	0.382	2.342
No access points	Baseline		
Driveway	Baseline		
Intersection	Baseline		
On-street parking	0.474	0.199	2.381
Degree of Curvature	0.003	0.001	1.973
Number of Observations: 2,901			
Number of Participants: 1,593			

One other difference between the two facilities was the significant impact of horizontal curvature on mean speeds across two-lane highways. This probably relates back to the lower design standards of these segments and the fact that much sharper curves are permitted to be built. The effect of horizontal alignment on travel speed is investigated at length in Chapter 6.

Like freeways, younger drivers were shown to travel at higher speeds compared to middle aged and older drivers. However, this effect was found to be smaller on two-lane highways which is probably due to the inherent differences between the nature of these facilities and the fact that two-lane highways do not allow for speeding as much. The author also investigated separate models for individual states; however, there found to be significant variability among coverage of a lot of these factors by individual states, resulting in insufficient samples in most cases.

As for the variability in speed, speeds were generally shown to be less variables at higher speed limits; however, some noises were observed which could be due to the sample size variation mentioned previously in the data sections. Also, speeds were shown to have more fluctuations under LOS C and below, a pattern found with the freeway events, as well. No additional differences were identified in the variability in speeds at lower LOSs due to the limited number of events available under such conditions.

Generally, the mixed-effect models were shown to provide improved fit as compared to simple linear models which is reflective of differences in driving patterns between different individual drivers. The select speeds were found to be variable among drivers as much as 4 mph on freeways, whereas this variability reduced to approximately 3 mph on two-lane highways.

Ultimately, this section of the report provides insights as to how drivers select their travel speed on freeways and two-lane highways. Drivers were found to adapt their speeds based upon changes in the roadway environment. Turning to the primary factor of interest, higher speed limits were found to result in higher travel speeds. However, the increases in travel speeds tended to be less pronounced at higher posted limits, which is consistent with recent research in this area (Burritt et al., 1976). Drivers tended to reduce their travel speeds along horizontal curves, under adverse weather conditions, and particularly under heavy congestion. The variability in travel speeds was also found to be influenced by several factors, including the posted speed limit, as well as the presence of congestion or work zone activities.

5.0 SPEED SELECTION ACROSS SPEED LIMIT TRANSITION AREAS

In addition to examining driver speed selection under fixed speed limits, a related item of interest is how drivers adapt their speeds when speed limits increase or decrease. This issue has important practical value as transportation agencies are often tasked with trying to control traffic speeds in high-risk scenarios, such as in work zone environments or under adverse weather conditions. It is also of general interest to discern how drivers alter their travel speeds when speed limits change. This section briefly summarizes a preliminary investigation of driver speeds while traversing through transition areas, where speed limits are either increased or decreased.

For each facility type, random effects linear regression models are estimated, which detail how speeds change when a speed limit reduction or increase is introduced. Side-by-side results are provided for freeways and two-lane highways, respectively. In each case, the mean baseline (i.e., pre-speed limit change) speed is provided, along with estimates of the mean increase (or decrease) in speeds associated with speed limit changes of 5 to 15 mph for freeways and 5 to 25 mph for two-lane highways. For both facility types, degree of curve was also shown to have an impact on speed.

5.1 Data Summary

Data were obtained for speed limit transition areas along both freeways and two-lane highways to gain a better understanding as to how drivers adjust their speeds when posted limits are increased or decreased. According to the manual on uniform traffic control devices (MUTCD), each sign is associated with a code identifier. This is equal to 218 for regulatory speed limit signs. Using the RID sign shapefile, speed limit signs, the associated message, and the corresponding location were extracted across the six study sites. Consequently, a line shape file was developed using these point data with an assumption that speed limit remains constant between every two consecutive speed limit signs. Subsequently, by overlaying the link layer from RID -which consists of short roadway segments generated through the data collection process- with this speed limit layer, the links along which the speed limit changed were identified. Next, select links were manually investigated using the Google Earth add-in in ArcMap to confirm that the links do satisfy the required condition. In addition to the speed limit criterion, the research team ensured with the VTTI that at least 10 traces corresponding to unique drivers are available along each of the requested links. Ultimately, unique link IDs were identified for a total of 79 and 106 locations across freeways and two-lane highways, respectively. This resulted in acquisition of a total of 2,578 and 2,940 traces across each of these facilities.

When examining the select links, they were found to vary significantly in their lengths and in the relative location of the sign to the link's beginning/end. Consequently, the time-series data were obtained for the 30 seconds immediately upstream and downstream of each identified link to capture sufficient data while approaching and passing the speed limit sign. For the purpose of analysis, fixed segments of up to 1000 ft upstream and downstream of the sign were created. This helped to better capture the drivers' behavior across the transition areas. This included segments where the speeds were stable under the initial posted limit, when the driver first noticed

the sign (approximately 400 ft upstream of the sign), and sufficient distance when they passed the sign until they reached a stable speed, again.

As mentioned previously, the location information was collected with a frequency of 1 Hz, while the speed information had higher resolution with frequency of 10 Hz. After some preliminary analysis, it was shown that using the time-series data with a 10-Hz frequency may provide finer and more accurate results in the analysis of these types of segments. As a result, first the obtained time-series were overlaid with the generated segments to extract the portions of trips that fell along these segments. Subsequently, the position of the vehicle during the intermediate time stamps were approximated using the travel speed calculated by equations 5 and 6:

$$x^{(t)} = x^{(t-0.1)} + v^{(t-0.1)} * 1.47 * 0.1 \quad (\text{Eq. 5})$$

$$x^{(t)} = x^{(t+0.1)} - v^{(t)} * 1.47 * 0.1 \quad (\text{Eq. 6})$$

where $x^{(t)}$ is the location of the vehicle at timestamp t ; $v^{(t)}$ is the travel speed at timestamp t in mph; and 1.47 is the conversion factor between mph to ft/s as the locations were measured in feet rather than miles. This resulted in identification of the location of all points included in the analysis set and their relative distance to the sign. Figure 16 displays a randomly selected trace going through a 5-mph increase in the posted speed limit prior and following to location interpolation.

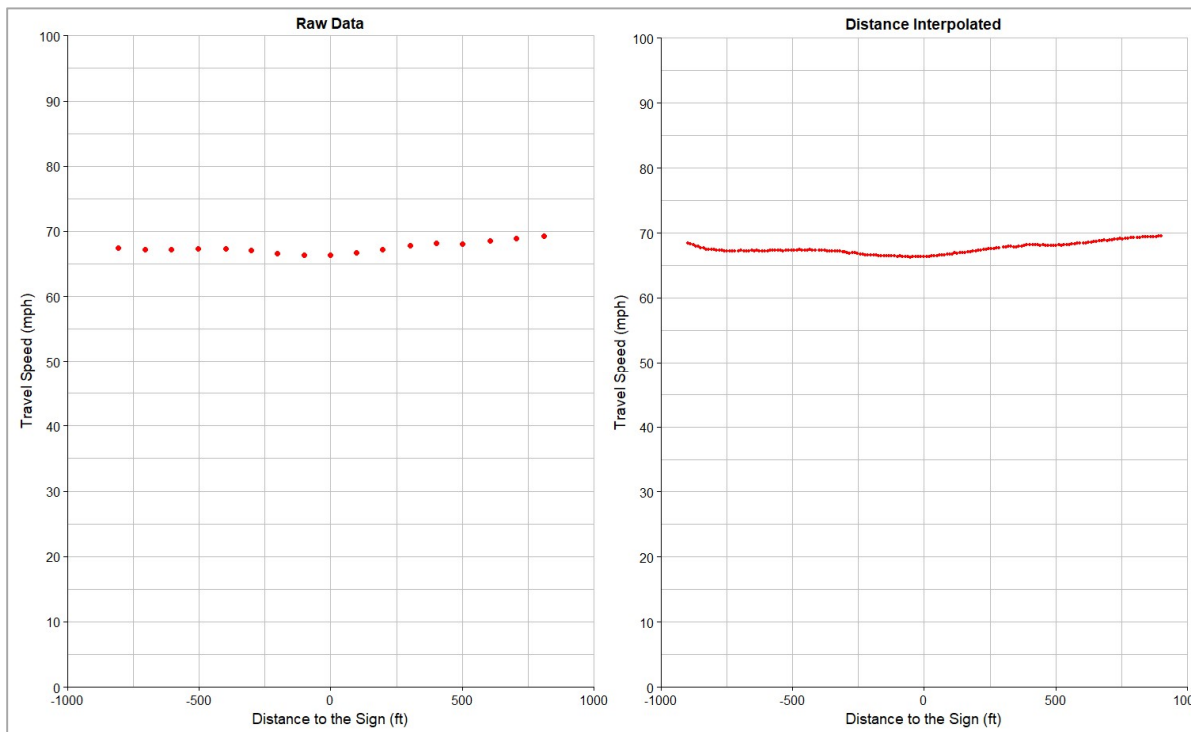

FIGURE 16 Example of a Trace with and without Location Interpolation.

Utilizing the fixed segments as base layer for each of the identified signs also helped to resolve the issue of mixed directions on two-lane highways. While there were unique route identifiers for each direction of travel on divided roadways, single route identifier was assigned to both directions on undivided roadways that may occasionally result in the information of the opposing direction being conflated to the data in the direction of travel.

In addition to approximating the vehicle location using the above equations, the geometric attributes across the intermediate time stamps were filled using the fill-forward method first, and the fill-backward method next. In other words, the geometric attributes were assumed to remain constant until a second observation was recorded. In case of missing geometric data during the beginning of a trace, when no information has yet been recorded, the data were filled using the succeeding observations.

Candidate locations were selected with an aim to cover a wide range of speed limit and speed limit changes, as well as geometric characteristics across both freeways and two-lane highways. However, differences in sample size across speed limits were inevitable due to prevalence of certain limits and limit changes across states. Table 8 provides an overview of the frequency of trips obtained at each speed limit by size of speed limit change. For freeways, the 55- and 65-mph limits had the highest frequencies which was due to the fact that two states in the study (i.e. New York and Pennsylvania) have only 55- and 65-mph limits in place. Consequently, traces under 10-mph increase/reduction had the majority, as well.

TABLE 8. Number of Obtained Trips by Speed Limit and Size of Speed Limit Change on Freeways

Initial Speed Limit (mph)	Size of Speed Limit Change (mph)						Total
	-15	-10	-5	5	10	15	
55	-	-	-	-	584	213	797
60	-	-	-	62	197	-	259
65	-	735	75	228	-	-	1,038
70	190	198	155	-	-	-	543
Total	190	933	230	290	781	213	2,637

Table 9 provides similar information for the number of trips obtained across two-lane highways. In this case, traces covered a wider range of limits and limit changes. Traces under 35- and 45-mph accounted for approximately half of the sample, whereas the traces under 60-mph had the minimum frequency. As far as frequencies across various limit changes, traces under 10-mph reduction held the highest frequency with 813 trips. On the other hand, there were only 97 traces undergoing a 15-mph reduction in posted speed limit. A few cases with 25 mph reduction/increase were identified, as well; however, these trips had to be removed from the sample due to limited frequencies.

TABLE 9. Number of Obtained Traces by Speed Limit and Size of Speed Limit Change on Two-Lane Highways

Initial Speed Limit (mph)	Size of Speed Limit Change (mph)								Total
	-20	-15	-10	-5	5	10	15	20	
25	-	-	-	-	30	174	48	-	252
30	-	-	-	17	40	76	38	-	171
35	-	-	135	41	78	338	-	138	730
40	-	32	72	73	160	62	-	-	399
45	7	51	291	184	-	223	-	-	756
50	-	14	88	26	31	-	-	-	159
55	129	-	227	37	42	-	-	-	435
60	-	-	-	46	-	-	-	-	46
Total	136	97	813	424	381	873	86	138	2,948

Figure 17 and Figure 18 display boxplots of travel speeds at various limits and limit changes upstream of the regulatory speed sign for freeways and two-lane highways, respectively. These plots show the travel speed at each speed limit separated by the upcoming limit change. Any differences between plots within a single speed limit are indicative of variations in speed selection patterns upstream of speed limit signs.

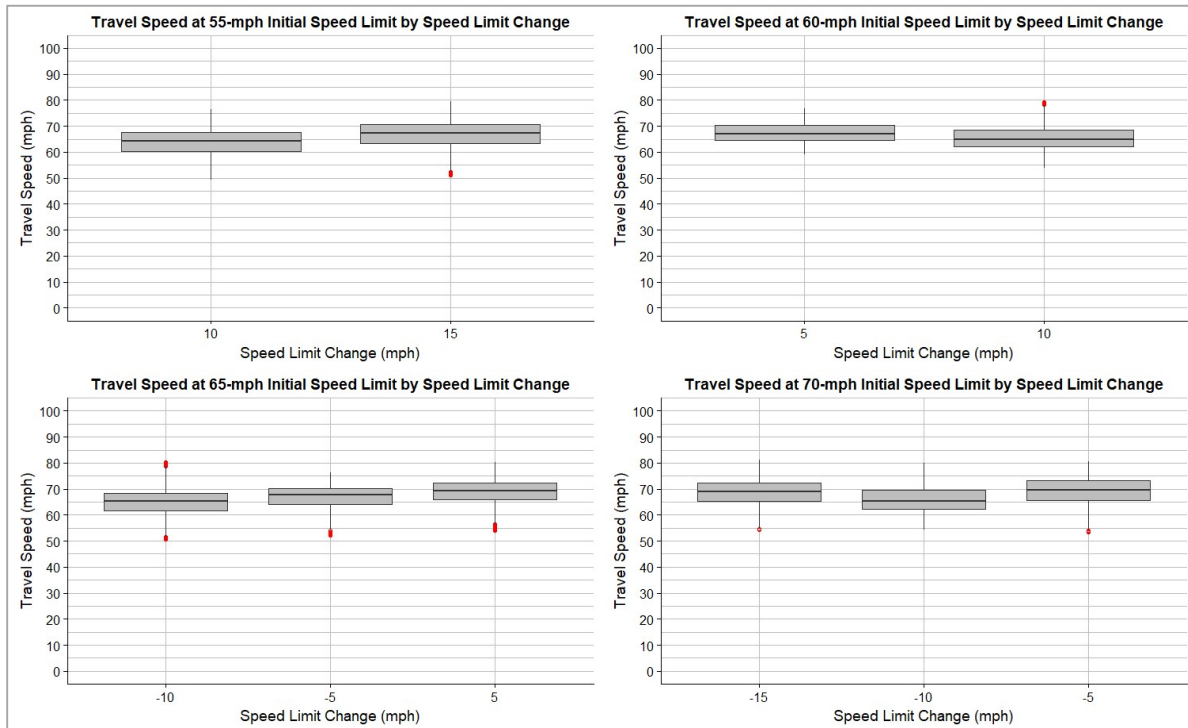

FIGURE 17 Upstream Travel Speeds by Posted Speed Limit and Size of Upcoming Speed Limit Change on Freeways.

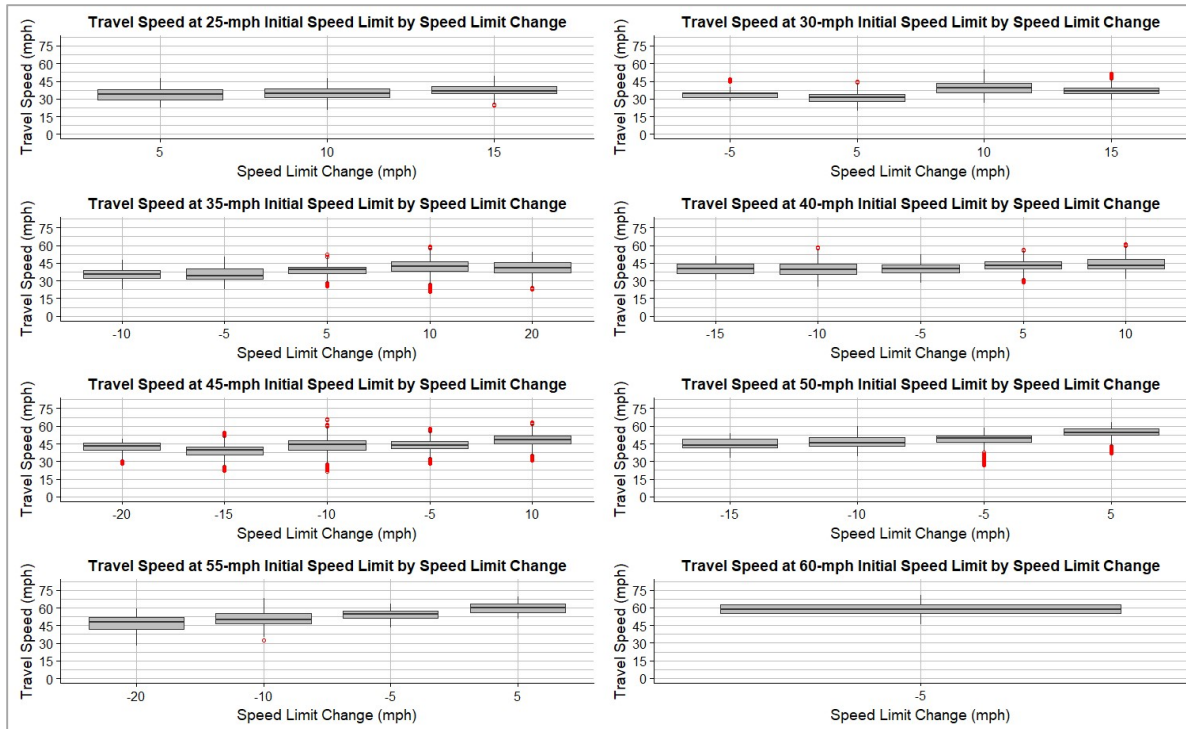

FIGURE 18 Upstream Travel Speed by Posted Speed Limit and Size of Upcoming Speed Limit Change on Two-lane Highways.

One other important issue related to speed selection behavior was the lack of traffic congestion information along these segments since the events were not necessarily among those reduced by VTTI. As such, no information was available to indicate whether the speed profiles are reflective of drivers' own choice of speed or they were essentially imposed from outside. To resolve this issue, forward video data for all the obtained trips were requested by the research team for review. In this process, video data were reviewed by team members with an aim to identify any incident, object, or condition that may potentially impact the select speed. Information was collected regarding presence of leading vehicles or pedestrians, weather condition, time of day (i.e. day versus night), and presence of workzones along the trip. This information was collected as a series of indicator variables that may simply be included in the models.

Figure 19 and Figure 20 display the information extracted from the video data for freeways and two-lane highways, respectively. These results indicate presence of leading vehicles in approximately 50 percent of the trips across both facilities. Also, while the majority of trips occurred under clear or cloudy weather conditions, nearly 6.5 percent of trips took place under snowy weather. The attempt was to match the data elements between these datasets with those available from the InSight reduced data described in the previous section to the extent possible.

The reduced video data were integrated with the time-series data to account for other factors such as presence of a leading vehicle that could have potentially altered drivers' select speed. However, video files were missing in some cases due to the cameras' malfunction or other reasons resulting in losing some traces when using the video data.

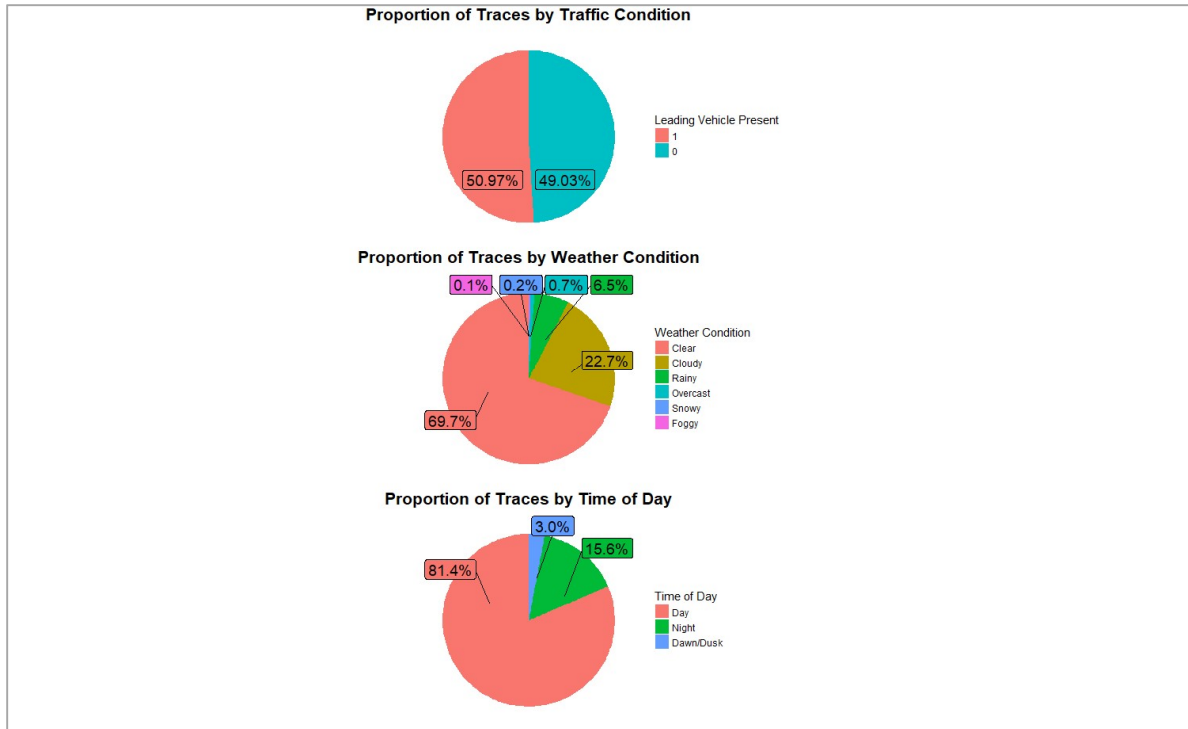

FIGURE 19 Overview of Reduced Video Data for Freeway Transition Areas.

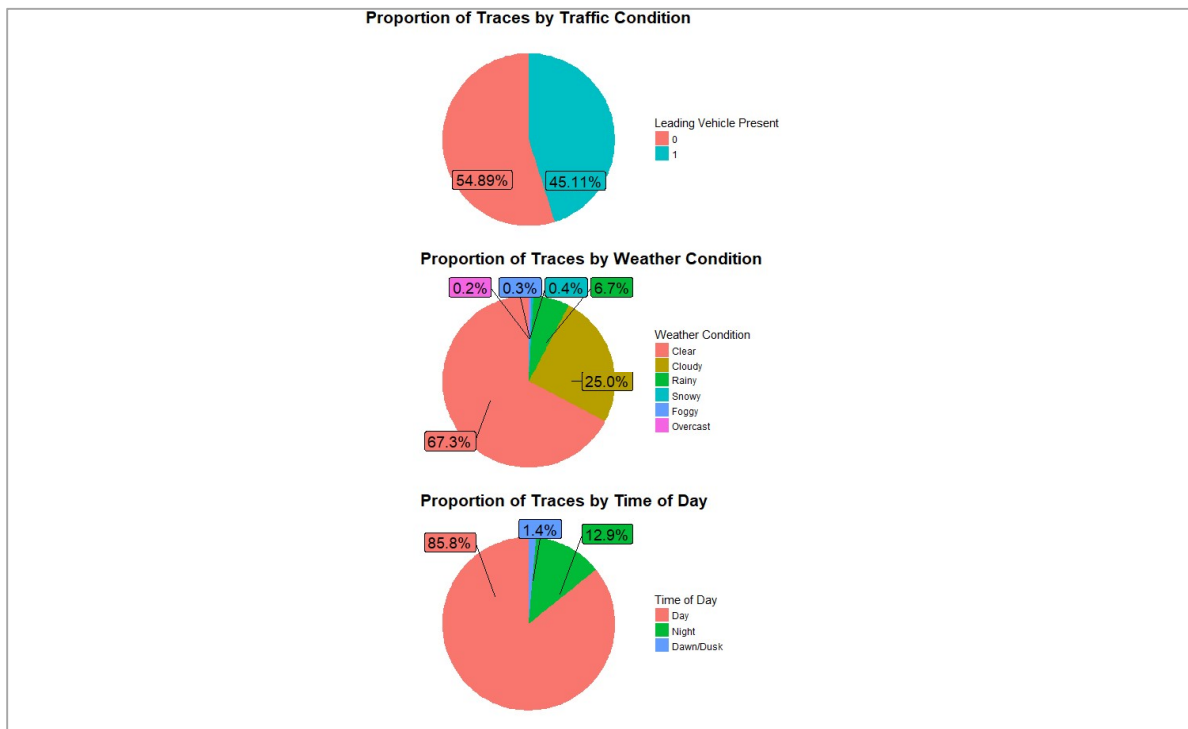

FIGURE 20 Overview of Reduced Video Data for Two-Lane Highway Transition Areas.

5.2 Statistical Methods

Like the previous section, speed analysis was conducted through estimation of mixed-effect OLS regression models. However, in this case speed profiles were included as time-series data instead of averaging the speed over the entire trip duration. This was imperative as the pattern in the speed profiles was of interest. Consequently, although the statistical models presented in this section are similar to those presented previously, there are some important differences to note with respect to how these analyses were conducted. In addition to the participant specific term described in the previous section, two other intercept terms were introduced. The first one was trip-specific that may vary across trips but retained same value for each individual trip. This parameter accounts for unobserved factors that are unique to each event. The second term was location specific and was designed to capture the correlation between traces that took place at same locations. Ultimately, the travel speed at each point is estimated through OLS regression models using the following equation:

$$S_{ijk}^{(t)} = \beta_i^{(t)} \mathbf{X}_i^{(t)} + \varepsilon_i^{(t)} + \delta_j + \gamma_i + \zeta_k \quad (\text{Eq. 7})$$

where $S_{ijk}^{(t)}$ is the travel speed corresponding to trip i , driver j , and location k at timestamp t ; $\beta_i^{(t)}$ is the vector of estimable coefficients, $\mathbf{X}_i^{(t)}$ is a vector of roadway geometric features, traffic attributes, and driver behavior/characteristics at timestamp t ; $\varepsilon_i^{(t)}$ is an error term capturing unobserved heterogeneity; δ_j is the driver-specific term corresponding to driver j to account for potential correlations between different observations corresponding to same individuals; γ_i is an intercept term corresponding to event i to capture correlations between observations within a single trip; and ζ_k is the location specific intercept that controls for unobserved heterogeneity in events corresponding to same location k . These intercept terms are assumed to be normally distributed with mean of zero and variance of σ^2 .

In essence, these terms captured the effects of important, unobserved variables that would otherwise lead to biased or inefficient parameter estimates. For example, some drivers may tend to drive faster (or slower). Consequently, δ_j is a parameter that retains the same coefficient for each driver in every trip (assuming the driver has multiple events in the database) and, thus, is able to capture general differences in speed selection behavior. Likewise, γ_i and ζ_k are parameters that account for unobserved factors that are unique to each specific trip and location, respectively. Adding these participant-, trip-, and location- specific terms results in what is commonly referred to as a random effects model. While these effects are specific to each trip or study participant, they are a random sample from the broader driving population.

5.3 Results and Discussion

For each facility type, random effects linear regression models were estimated, which detail how speeds change when a speed limit reduction or increase is introduced. In each case, the mean baseline (i.e., pre-speed limit change) speed is provided, along with estimates of the mean increase (or decrease) in speeds associated with speed limit changes of 5 to 15 mph for freeways and 5 to 20 mph for two-lane highways. Table 10 demonstrates the results of the mixed linear regression model estimated for freeway trips across transition areas.

TABLE 10. Mixed Effect Linear Regression Model for Travel Speed across Speed Limit Transition Areas on Freeways

	Total Sample			No Leading Vehicle Sample		
Random Effects:						
Groups	Variance	Std. Dev.		Variance	Std. Dev.	
Trip ID	17.238	4.152		15.979	3.997	
Location ID	3.930	1.982		5.195	2.279	
Participant ID	3.893	1.973		2.685	1.639	
Residual	2.247	1.499		1.924	1.387	
Fixed Effects:						
Model Term	Coeff.	Std. Err.	t-stat	Coeff.	Std. Err.	t-stat
Intercept	63.780	0.358	177.924	63.521	0.386	164.672
55-mph limit	Baseline			Baseline		
60-mph limit	Baseline			Baseline		
65-mph limit	0.934	0.281	3.326	0.863	0.269	3.206
70-mph limit	2.990	0.443	6.752	2.320	0.416	5.575
5-mph limit reduction	-0.341	0.018	-19.471	-0.891	0.024	-37.931
10-mph limit reduction	-1.012	0.010	-104.750	-0.768	0.012	-62.712
15-mph limit reduction	-1.422	0.026	-54.726	-1.429	0.028	-51.330
5-mph limit increase	0.745	0.015	51.123	0.686	0.018	38.402
10-mph limit increase	1.118	0.010	107.972	1.077	0.013	81.851
15-mph limit increase	1.515	0.021	70.882	1.371	0.026	53.488
No Leading Vehicle	Baseline			-		
Leading Vehicle Present	-0.448	0.242	-1.853	-		
Clear weather	Baseline			Baseline		
Rain	-1.079	0.469	-2.299	N/S		
Snow	N/S			N/S		
Age 16 to 24	2.080	0.335	6.204	2.501	0.439	5.702
Age 25 to 59	2.150	0.320	6.714	2.357	0.420	5.619
Age 60 or above	Baseline			Baseline		
Null Log-Likelihood			-1221717			-582588
Log-Likelihood			-562107			-297148
Null AIC			2443437			1165180
AIC			1124249			594325
Null BIC			2443459			1165200
BIC			1124429			594475
Number of Observations: 304,799				Number of Observations: 168,140		
Number of Events: 1,525				Number of Events: 829		
Number of Participants: 951				Number of Locations: 623		
Number of Locations: 262				Number of Participants: 218		
N/S: Not Significant						

For such traces, it is interesting to note that speeds remained relatively stable, regardless of the posted limit. No differences were observed between mean speeds at 55- and 60-mph limits where the mean speeds were approximately 63.8 mph. The mean speeds increased by only 0.9 mph at 65 mph and approximately 3 mph at 70 mph (both values relative to the 55-/60-mph limits). This indicates that travel speeds are significantly above the posted limits upstream of the transition points at lower limits, whereas the opposite is true at 65- and 70-mph limits. This probably relates back to the nature of these trips. It is imperative to keep in mind that all traces at 70-mph initial speed limit were upstream of a speed reduction zone, whereas the traces at 55-mph initial speed limits were all followed by speed limit increases of 10 or 15 mph. This could be another reason for the observed mild speed differences, meaning that drivers start to adjust their speeds upstream of the sign, before limit change occurrence. As shown by past literature, drivers tended to change their speeds by lesser amounts at higher posted limits (Parker, 1997; Kockelman et al., 2006; Mannering, 2007).

When changes did occur, the actual speed changes were significantly less than the associated change in the posted limit. For example, increases of 5, 10, and 15 mph, result in increases of 0.7, 1.1, and 1.5 mph, respectively. When speed limits were reduced, similarly muted impacts occurred. When limits were reduced by 5 mph, travel speed decreased by only 0.3 mph; this reduction was slightly greater when limits were reduced by 10 and 15 mph; travel speed reduced by 1.0 and 1.4 mph at each of these limit changes, respectively. It is important to note that while these reductions turned out to be much smaller than expected, they were all statistically significant at a 99 percent confidence interval; meaning that though minimal, some changes in travel speed did occur across transition areas.

Similar to the results from the preceding analyses, some other variables were also found to significantly impact travel speeds aside from posted limits. Presence of a leading vehicle was shown to reduce the mean speeds by approximately 0.5 mph. In addition, travel speeds were found to be lower under rainy weather condition; however, no significant effect associated with snowy weather was found which is probably due to the limited sample size available for such trips. Again, mean speeds were shown to be higher among younger and middle-aged drivers.

In addition, a separate model was estimated for those events that were not found to follow any leading vehicle. This was done with an aim to examine drivers' select speed under free-flow condition. Parameter estimates were found to be relatively stable between the two models. However, the coefficients for the two age categories slightly increased which is probably reflective of more opportunities for speeding when no leading vehicle was present. The slight reductions in speeds in absence of leading vehicles (compared to the total sample), as well as the increased estimates for driver age indicate that when other vehicles are present drivers tend to adjust their speeds with regard to the moving flow. When examining the goodness-of-fit measures, both models were shown to be relatively successful.

Turning to the results for the analysis of two-lane highway trips, presented in Table 11, speeds were comparable on highways posted at 25 or 30 mph where no statistically significant difference was observed. As in the analyses presented previously, travel speeds tended to increase by lesser amounts at higher posted speed limits with an exception for those at 60-mph.

TABLE 11. Mixed Effect Linear Regression Model for Travel Speed across Speed Limit Transition Areas on Two-Lane Highways

Total Sample			No Leading Vehicle Sample			
Random Effects:						
Groups	Variance	Std. Dev.		Variance	Std. Dev.	
Trip ID	16.369	4.046		14.793	3.846	
Location ID	1.580	1.257		3.468	1.862	
Participant ID	13.554	3.682		11.550	3.399	
Residual:	5.572	2.360		4.816	2.195	
Fixed Effects:						
Model Term	Coeff.	Std. Err.	t-stat	Coeff.	Std. Err.	t-stat
Intercept	36.519	0.585	62.406	36.879	0.643	57.398
25-mph limit	Baseline			Baseline		
30-mph limit	Baseline			Baseline		
35-mph limit	2.798	0.663	4.222	2.938	0.722	4.068
40-mph limit	5.689	0.812	7.003	5.265	0.848	6.208
45-mph limit	7.007	0.675	10.378	6.886	0.718	9.589
50-mph limit	10.483	1.036	10.121	10.120	1.170	8.650
55-mph limit	11.896	0.775	15.355	11.897	0.830	14.334
60-mph limit	21.139	2.173	9.729	21.668	2.191	9.888
5-mph limit reduction	-1.198	0.023	-52.281	-1.183	0.028	-41.531
10-mph limit reduction	-2.579	0.016	-159.506	-2.634	0.020	-130.610
15-mph limit reduction	-3.622	0.053	-68.732	-3.147	0.072	-43.554
20-mph limit reduction	-6.032	0.064	-94.657	-6.308	0.083	-75.702
5-mph limit increase	1.479	0.024	62.140	1.352	0.027	49.241
10-mph limit increase	1.988	0.016	121.862	1.995	0.020	101.844
15-mph limit increase	1.937	0.070	27.538	1.344	0.092	14.592
20-mph limit increase	3.069	0.051	60.150	3.802	0.073	51.937
Degree of Curvature	-0.162	0.003	-53.339	-0.241	0.004	-53.652
No Leading Vehicle	Baseline			-		
Leading Vehicle Present	-1.210	0.240	-5.046	-		
Age 16 to 24	1.306	0.293	4.462	1.836	0.392	4.680
Age 25 to 59	0.878	0.293	2.993	0.951	0.393	2.419
Age 60 or above	Baseline			Baseline		
Null Log-Likelihood			-1,299,120			-738,458
Log-Likelihood			-696,226			-386,818
Null AIC			2,598,245			1,476,919
AIC			1,392,498			773,681
Null BIC			2,598,267			1,476,940
BIC			1,392,743			773,902
Number of Observations: 303,230			Number of Observations: 173,892			
Number of Events: 1,491			Number of Events: 864			
Number of Participants: 1,046			Number of Locations: 666			
Number of Locations: 410			Number of Participants: 351			

This could be due to the limited sample available for these traces as presented in Table 9, as well as the fact that only one type of limit change (i.e. 5-mph reduction) occurred at this limit. Also, travel speeds were shown to be markedly above the posted limit at lower speeds and below the posted limit at higher limits. This is a similar trend to that observed with freeway trips. The mean speeds were shown to be significantly above the posted limit at 25 and 30 mph (approximately 36 mph). It is essential to note that all trips at an initial speed limit of 25 mph were upstream of a speed limit increase zone with the majority undergoing a 10-mph increase. On the other hand, all trips under 60-mph limit and approximately 90 percent of those at 55-mph limit went through speed limit decreases.

Interestingly, the speed limit changes were associated with much greater impact on two-lane highways than on freeways. For example, speeds were shown to decrease by 3.6 and 2.6 mph where reductions of 15 and 10 mph occur. These values are roughly two times greater than what was observed for freeways. Much of this may be attributable to the nature of two-lane highways as speed changes generally occur in concert with changes in functional class, land use, access density, and in other ways that significantly alter the driving environment. Drivers were found to decrease their speeds by roughly 1.2 mph for every 5-mph reduction in the posted limit. Reductions of 10, 15, and 20 mph in posted limit decreased mean speeds by only 2.5, 3.6, and 6 mph. It is interesting that much larger changes occurred when the speed limit was decreased as opposed to increased, which may be reflective of concerns as to speed enforcement in addition to some of the other factors noted previously.

Although the speed changes seem to be much lower than what was expected, it is crucial to interpret the results considering both mean baseline speeds and the trip frequencies. For example, all trips at a 60-mph initial limit went through a 5-mph limit increase. For these traces, mean baseline speed was around 57.6 mph upstream and 56.5 mph downstream the sign. Likewise, upstream mean speed was found to be 48.5 mph where initial posted limit was 55 mph. When looking at the frequency distribution of trips, nearly 50 percent of such trips went through a 10-mph limit reduction. Adding such reductions' associated parameter estimate results in a downstream speed of 46 mph which is comparable to the downstream speed limit of 45 mph. These results indicate that drivers start adjusting their travel speeds upstream of the regulatory speed sign. This behavior probably starts as soon as drivers notice the sign. Such behavior is probably more pronounced on roadways with which the drivers are more familiar with and had experienced driving through.

Unlike freeways, mean speeds were shown to be notably reduced across horizontal curves. An impact that was found to be more pronounced when no leading vehicle was present. Due to the substantial impact of horizontal alignment on travel speeds, this impact was investigated in greater detail in Section 6.0. As for driver age, younger and middle-aged drivers were found to be associated with higher travel speeds. However, such impacts were found to be less pronounced across transition areas as compared to areas with no limit change. This is reflective of stronger role of roadway condition rather than individuals' behavior when selecting speeds across transition areas. These models were all found to provide significantly improved fit when considering different goodness-of-fit measures including AIC, BIC, and log-likelihood.

6.0 SPEED SELECTION ON HORIZONTAL CURVES

The results presented previously demonstrate the significant impact of horizontal curvature on driver speed selection, especially on two-lane highways. Consequently, the third focus area of was to examine driver speed selection along horizontal curves on two-lane highways and evaluate the efficacy of advisory speed signs. Few studies have investigated the impact of advisory speed signs on mean speeds and drivers' level of compliance with them in the past and have generally shown minimal or no impact associated with installation of such signs. Also, majority of these studies investigated the drivers' compliance rate or the average speed changes across the curves and fail to account for changes in the speed profiles upstream and downstream of the curves. In addition, much of such studies date back to the 90's or earlier (Ritchie 1972, Chowdhury et al. 1991, Bennett and Dunn 1994) which necessitates revisiting this issue. This section investigates the general drivers' choice of speed on horizontal curves across two-lane highways and the impact of advisory speed signs on them.

Advisory speeds are introduced at certain locations to inform drivers of a lower recommended speed in conditions where the safe speed is below the posted speed limit. Such locations include sharp curves, highway ramps and roundabouts, as well as locations where the sight distance is limited. According to the Manual on Uniform Traffic Control Devices (MUTCD), the difference between the mandatory speed limit and the advisory speed typically ranges from 5 to 25 mph (FHWA, 2009). Table 12 outlines the criteria developed in the 2009 edition of the MUTCD for installing advisory speed signs. This includes conditions where advisory speed signs are required, recommended, or optional. However, it is imperative to note that advisory speeds do not mandate the driver to follow the recommended speed (i.e. citation cannot be issued by law enforcements). Several studies showed that advisory speeds are generally too low compared to what drivers perceive as comfortable (Bennett and Dunn, 1994; Chowdhury et al., 1991).

TABLE 12. MUTCD Criteria for Selection of Horizontal Alignment Sign (FHWA, 2009)

Type of Horizontal Alignment Sign	Difference Between Speed Limit and Advisory Speed				
	5 mph	10 mph	15 mph	20 mph	25+ mph
Turn (W1-1), Curve (W1-2), Reverse Turn (W1-3), Reverse Curve (W1-4), Winding Road (W1-5), and Combination Horizontal Alignment / Intersection (W10-1)	Recommended	Required	Required	Required	Required
Advisory Speed Plaque (W13-1P)	Recommended	Required	Required	Required	Required
Chevrons (W1-8) and/or One Direction Large Arrow (W1-6)	Optional	Recommended	Required	Required	Required
Exit Speed (W13-2) and Ramp Speed (W13-3) on exit ramp	Optional	Optional	Recommended	Required	Required
Note: Required means that the sign and/or plaque shall be used, recommended means that the sign and/or plaque should be used, and optional means that the sign and/or plaque may be used.					

There are also inconsistencies in the installation of advisory speed signs between states, and even between locations within a single state (Ritchie, 1972). Consequently, the efficacy of such signs is still under question and requires further investigation. Examination of drivers' behavior in response to such signs and how they adjust their speed considering the combination of regulatory and advisory speeds when negotiating horizontal curves can shed light on the actual effect of such signs and the levels of drivers' compliance.

Although speed limits and advisory speed signs provide drivers with clues as to what a reasonable travel speed on a roadway is, driver speed selection behavior has been shown to be more sophisticated and difficult to untangle as it is driven by a multitude of factors, speed limit being one of them (Hamzeie et al., 2017b). As a result, there continues to be a debate as to how drivers react to different posted speed limits, visual cues, and environmental conditions, and recent efforts have sought to quantify the relationship between posted speed limit, operating speed, and crash risk.

The intent of all these efforts to regulate travel speed is to lower crash frequencies and the associated level of injuries while allowing drivers to travel at a reasonably high speed. However, travel speed is not the sole contributing factor to safety critical (i.e. crash/near-crash) events. Traffic crashes may occur due to a combination of factors including poor roadway design, adverse environmental conditions, or inappropriate driver behavior. Researchers have long been trying to examine crashes to identify the contributing factors, suggest potential solutions to eliminate them, or mitigate the consequences (Aarts and Van Schagen, 2006; Solomon, 1964; Cirillo, 1968; Munden, 1967). However, these efforts were mostly limited to examination of crashes as outcomes of geometric attributes and traffic conditions and lacked thorough investigation of the impacts that driver behavior and their characteristics have on the resulting incident. However, according to the National Motor Vehicle Crash Causation Survey (NMVCCS), human error is the critical reason for 93% of crashes where critical reason is perceived as the last event in the crash causal chain (NHTSA, 2008). Consequently, assessing driver behavior at time of safety critical events, as well as during normal driving events provide insights as to the factors that distinguish between such incidents. Identification of crash contributing factors including driver behavior and the associated characteristics, as well as the cross-sectional and geometric attributes will help to recommend appropriate countermeasures, improve existing design criteria, revise in-place legislations if necessary, and better target public education and outreach.

Horizontal curves and roundabouts, as well as exit and entrance ramps are integral components of highway design. While these roadway elements have long drawn significant amount of attention from researchers, crash statistics show that such locations still experience a disproportionate number of severe crashes. As a result, various methods and techniques have been employed to warn drivers as to potential hazards associated with driving across such locations. One of such methods is to install curve warning signs with or without advisory speeds.

Warning signs are generally installed to notify drivers with a change in alignment that may not be evident to the road user. Advisory speed signs often supplement warning signs to recommend drivers a lower speed with which the curve can be traversed comfortably. A comprehensive list

of such signs is presented in the Manual on Uniform Traffic Control Devices (MUTCD) and is shown in Figure 21.

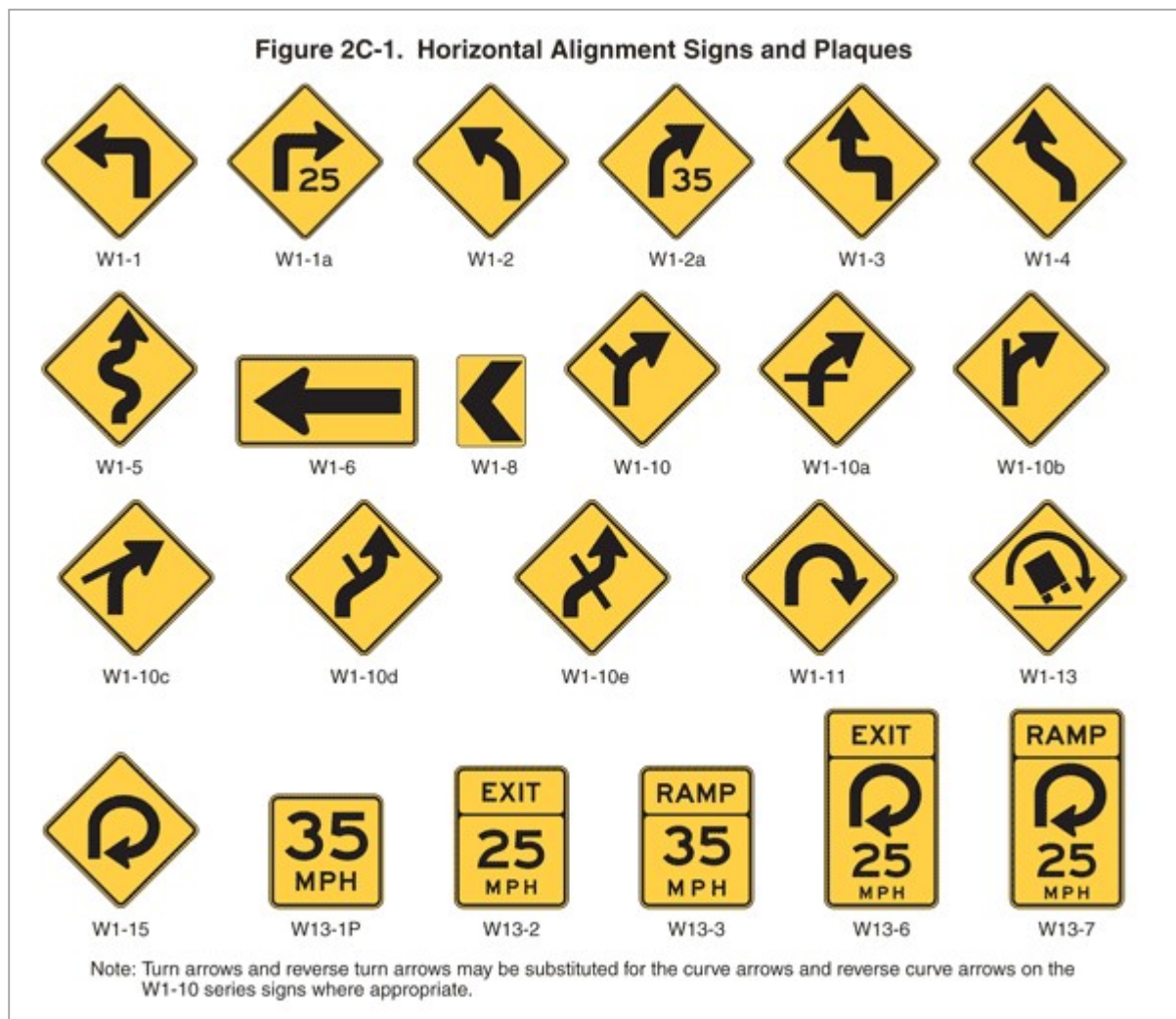

FIGURE 21 Horizontal Alignment Signs and Plaques Outlined in MUTCD (FHWA, 2009).

According to the Federal Highway Administration (FHWA), curve advisory speeds can be determined using six different methods: (1) Direct Method (using field measurements of curve speeds), (2) Compass Method (through a single-pass survey technique using a digital compass), (3) Global Positioning System (GPS) Method (through a single-pass survey using a GPS and software to derive curve radius and deflection angle), (4) Design Method (using the curve radius and deflection angle from the as built plans), (5) Ball-Bank Indicator Method (record the ball-bank indicator through a collection of field driving tests), and (6) Accelerometer Method (record the maximum lateral gravitational force using an electronic accelerometer device and a GPS receiver through a collection of field driving tests). While this list included most of methods that are currently being used by agencies to determine the advisory speeds, some other methods have previously been used to designate the advisory speed most important of which is the American Association of State Highway Officials (AASHTO)'s method which simply derive the advisory

speed using superelevation, side friction factor, and curve radius. Due to this variety in the methods and procedures to determine the advisory speeds, there is no consistency in determining advisory speed among different states, and even within a state at different locations. This has impacted the plausibility and effectiveness of such signs. Consequently, numerous studies tried to examine the influence of advisory speed signs on travel speed and how drivers adhere to such signs.

In one of the earlier studies, 50 drivers drove through 162 curves which can be grouped into three different categories: (1) curves with no warning signs, (2) curves with warning signs, and (3) curves where advisory speed sign was installed in conjunction with warning signs. The advisory speeds ranged between 15 to 50 mph, and the state speed limit was 60 mph at the time of study. Lateral acceleration, as well as travel speed data were collected. Interestingly, Ritchie reported that drivers travel at higher speeds on curves where a warning sign was installed as compared to those with no sign, and such behavior was more pronounced when an advisory speed sign was present in addition to curve warning sign. The participants were found to drive at higher speeds compared to what was recommended by the sign with an exception for advisory speeds of 45 and 50 mph where the subjects' speeds were roughly the same as the recommended speed which could be related to the posted speed limit of 60 mph at the time (Ritchie, 1972).

A 1991 study examined speed data on 28 curves to investigate drivers' compliance with in-place advisory speeds. The results showed the level of compliance to vary between different advisory speeds, with zero percent complying with advisory speeds of 15-20 mph, and only 43 percent adhering to the 45-50 mph advisory speeds. They also reported that the actual observed drop in vehicles' speeds was less than half of what was suggested by the advisory speed sign, and is detailed in Table 13 (Chowdhury et al., 1991).

TABLE 13. Observed Average Speed Reduction Reported (Chowdhury et al., 1991)

State	Suggested Speed Drop (mph)	Actual Speed Drop (mph)
Virginia	15.8	4.6
Maryland	18.7	10.4
West Virginia	7.9	4.9
All Curves	15.1	6.1

Bennett and Dunn (1994) evaluated drivers' speed selection behavior on 23 different curves in New Zealand and concluded that in only less than 39 percent of cases were the speeds below the design values. They further investigated those curves with advisory speeds in place and observed that the 85th percentile speeds were approximately 10-28 km/h (9 to 17 mph) greater than that of advisory speed sign.

The effectiveness of advisory speeds was also examined using drivers' eye scanning and fixation duration. Zwahlen (1987) concluded that advisory speeds do not have significant impact on reducing travel speeds under dry weather conditions when compared to curve warning signs.

However, it was noted that such signs may be of more beneficial impacts when considering heavy vehicles and motorcycles.

In general, previous research has shown lack of efficacy when installing advisory speed signs. Most critiques have attributed this relative ineffectiveness to the inconsistencies in methods utilized to determine the advisory speeds. The majority of research conducted to evaluate the impact of advisory speeds have shown travel speeds to be higher than what was recommended by the sign. This could be hazardous when drivers, on the other hand, assume consistencies between locations. For example, a driver who travels through a curve on a daily basis may realize that he could still travel comfortably and safely at speeds beyond the advisory speed. Following such perception, he may assume for same settings when travelling through an unfamiliar curve with similar sign where the design speed is lower than that of previous location. As such, further research as to the impact of advisory speed signs on travel speed and safety, as well as investigating how same individuals react to different conditions is warranted.

6.1 Data Summary

A procedure similar to that of speed limit transition areas was followed to identify links associated with advisory speed signs. Using the various speed limit/advisory speed combinations from Table 12, a series of links associated with advisory speed signs were identified. Subsequently, these links and the identified signs were reviewed using the Google Earth add-in available in ArcMap to confirm that the select candidates are indeed curve advisory speed signs and do display the listed message. Also, like the previous dataset, the minimum 10 traces per link criterion was considered. Ultimately, a total of 135 links associated with curve advisory speed signs were identified. In addition, 29 links were identified corresponding to curves without advisory speed signs to be utilized as control segments. When selecting these links, curve radius and length, as well as posted speed limits were considered so that they match the ones in the other set to the extent possible. However, in most cases it was difficult to identify identical curves since if a collection of characteristics does satisfy the criteria for installation of curve advisory signs, it is somewhat unlikely to have them not being associated with an advisory sign. As with the speed limit transition areas, requested time-series data were extended for the 30 seconds immediately before and after each link where a sign was located. Ultimately, a total of 4,604 and 842 traces were obtained for curves with and without advisory speed signs, respectively. The frequency distribution of the obtained trips is provided in Table 14. The increase in the number of trips in this table compared to the previously mentioned values is due to the fact that in a few cases extending the trips for 30 seconds upstream and downstream of the sign link resulted in capturing other advisory signs, and as a result the total number of trip segments used for analysis increased.

One complication associated with preparation of this set of data related back to the point-based nature of the sign shapefiles. While regulatory speed limits were assumed consistent between consecutive signs, this assumption does not apply to advisory speed signs. Subsequently, a curve inventory dataset was created for the collection of curves for which the data were requested. For each location, information was collected as to the location of the curve beginning, referred to as point of curvature (PC), curve end, referred to as point on tangent (PT), and advisory speed sign. These segments were extended for 400 ft upstream of the sign to capture the patterns in travel speeds preceding to the sign, as well. Once this inventory was put together, these segments were

overlaid by the obtained time-series data using the ArcMap’s “Overlay Route Events” tool, described in Section 3.3, to integrate the obtained data with the curves and the associated characteristics.

TABLE 14. Frequency Distribution of Obtained Trips by Posted Speed Limit and Suggested Speed Reduction

Posted Speed Limit (mph)	Suggested Speed Reduction (mph)						Total
	0	5	10	15	20	25	
30	191	278	220	5	-	-	694
35	50	693	250	114	211	23	1,341
40	127	60	103	81	-	-	371
45	213	658	949	177	8	178	2,183
50	65	14	48	60	22	-	209
55	87	56	564	201	27	9	944
Total	733	1759	2,134	638	268	210	5,742

Like speed limit transition areas, time-series data were used with 10-Hz frequency where travel speed information was recorded with a resolution of 10th of a second. Similarly, the intermediate locations were interpolated using Equation 8 and Equation 9. This was done to capture the changes in drivers’ select speed both upstream and downstream of the curve.

Figure 22 displays the boxplots of the baseline mean travel speeds by posted limit and advisory speed. Some slight differences are evident between the baseline speeds based on the size of upcoming advisory speed. These plots indicate that upstream speeds were decreased as the difference between posted speed limit and advisory speed increased. This finding indicates that drivers begin adjusting their speeds far upstream of the curve PC, especially when larger reductions are suggested.

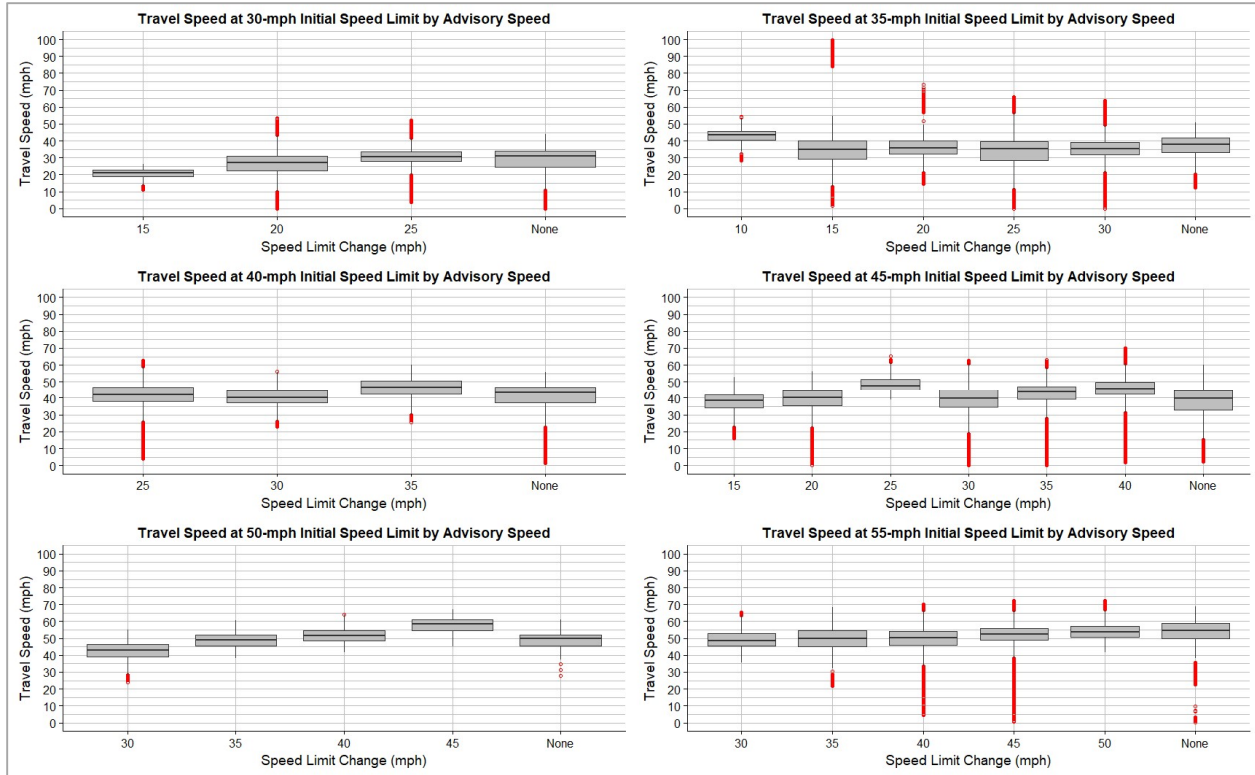

FIGURE 22 Upstream Travel Speed by Posted Speed Limit and Advisory Speed.

In addition, video data were obtained and reviewed by the research team following similar process outlined previously. Figure 23 presents a summary of the reduced video data. Nearly 45 percent of the subject vehicles were found to be following a leading vehicle which may potentially impact travel speeds. Although the majority of trips occurred under clear weather condition, 8.5 percent of them were found to occur under rainy weather, whereas less than 1 percent were associated with snowy weather condition.

Next the integrated data were analyzed using two different methods. First, mixed effect linear regression models were estimated as described previously. In addition, time-series data were analyzed using Functional Data Analysis (FDA) methods at select locations to better investigate the patterns in drivers' speed selection behavior. Following section describes the underlying theory of FDA and discusses the steps performed to evaluate the patterns in the functional data.

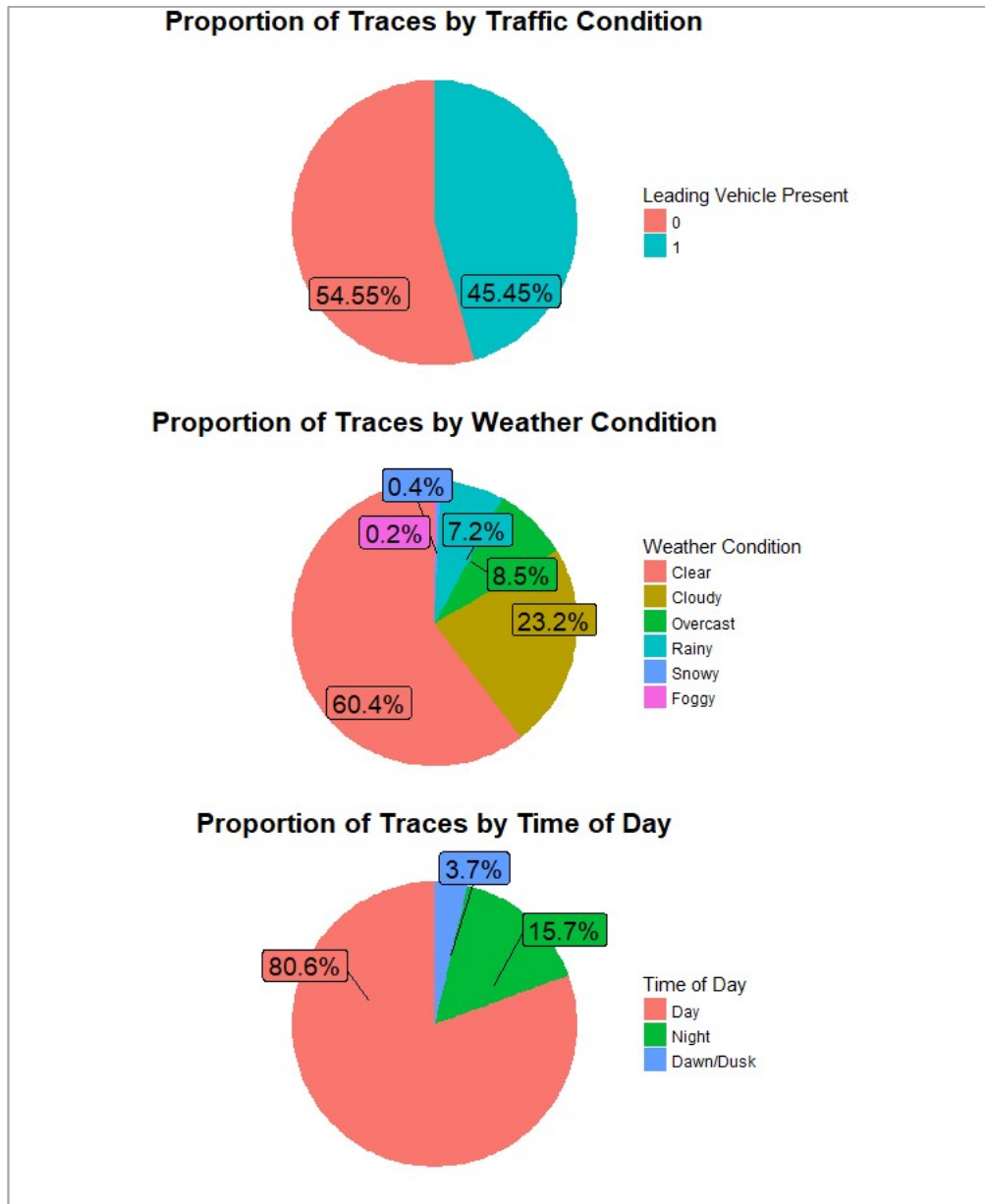

FIGURE 23 Overview of the Reduced Video Data for Curves.

6.2 Statistical Methods

In addition to investigation of driver behavior with respect to speed selection across speed limit transition areas and horizontal curves, a more in-depth analysis of behavioral data was conducted through employing Functional Data Analysis (FDA) methods for select locations. This study used the procedures for FDA as outlined by Ramsay and Silverman in the book ‘Functional Data Analysis’ (Ramsay, 2006). FDA is essentially employed by researchers (where possible) to demonstrate the existing data in a way that more prominent characteristics can be highlighted. Also, such analysis is broadly conducted to further examine the existing pattern and variations in the data, as well as to identify the sources resulting in such variations in the outcome or dependent variable. More importantly, what makes FDA a strong analysis candidate method is

its ability to compare the variation and patterns between two or more sets of data. Such datasets may be made of different replicates of same function, or different functions built from same replicates.

In the context of FDA, functions are presented as linear combination of basis functions. Fourier and B-spline basis functions are broadly used for FDA purposes. Fourier basis functions are generally employed when some sort of periodicity and cyclic trends are present, whereas use of B-spline basis functions is suggested in absence of such repetitive patterns. The basic assumption of FDA is that the observed discrete data values are basically snapshots of an underlying smooth function at any given time (or other continuous domain). In addition, the underlying function is assumed to be smooth to some degree, meaning that certain number of derivatives are defined and computable. While smoothness of the assigned function is one of the fundamental assumptions of FDA, the discrete observed vector $\mathbf{y} = (y_1, y_2, y_3, \dots, y_n)$ may not exhibit such property due to the presence of noise in the data, and is specified as:

$$y_j = x(t_j) + \varepsilon_j \quad (\text{Eq. 8})$$

where y_j is the observed value at point j , $x(t_j)$ is the assigned function evaluated at point t_j , and ε_j is the error or disturbance term, normally distributed with mean zero and variance of σ^2 . As alluded to previously, functional data are generated through a weighted sum of K basis functions φ_k as:

$$x(t) = \sum_{k=1}^K c_k \varphi_k(t) \quad (\text{Eq. 9})$$

where c_k is the k^{th} element of the vector of coefficients denoting the weights, and φ_k is the k^{th} basis function. For speed analysis purposes conducted as part of this study, B-spline basis functions were used as they best fit data that are open-ended and do not exhibit any periodic patterns. The roughness penalty, or regularization, approach was used to smooth the discrete functional data as it not only preserves the general properties of basis functions, but also generates better results particularly when considering derivatives.

The objective of an FDA was to fit the discrete measures $y_j, j = 1, 2, \dots, n$ a function $x(t)$ such that it minimizes the residuals sum of squares. In a standard model, such measure is defined as:

$$SMSSE(\mathbf{y}|\mathbf{C}) = \sum_{j=1}^n [y_j - \sum_k c_k \varphi_k(t_j)]^2 = (\mathbf{y} - \mathbf{\Phi c})'(\mathbf{y} - \mathbf{\Phi c}) \quad (\text{Eq. 10})$$

However, an underlying assumption for this standard model is that the residuals (ε_j 's) are independently and identically distributed (IID) with mean of zero and constant variance of σ^2 which is often violated with real world data. Consequently, to account for autocorrelated errors, Equation 10 is expanded to:

$$SMSSE(\mathbf{y}|\mathbf{C}) = (\mathbf{y} - \mathbf{\Phi c})\mathbf{W}'(\mathbf{y} - \mathbf{\Phi c}) \quad (\text{Eq. 11})$$

where \mathbf{W} is the inverse variance-covariance matrix.

One other concern that arises when smoothing the functional data is the tradeoff between smoothness and bias. While the observed value of y_j is an unbiased estimator for $x(t_j)$, it may result in high variance curves which exhibit high frequency local fluctuations. As such, a new term is added to Equation 11 to penalize the sum of squared errors for excessive roughness, resulting in Equation 12:

$$PENSSE_\lambda(x|\mathbf{y}) = [\mathbf{y} - x(\mathbf{t})]' \mathbf{W} [\mathbf{y} - x(\mathbf{t})]^2 + \lambda PEN_2(x) \quad (\text{Eq. 12})$$

where λ is a smoothing parameter, and PEN_2 is a measure of roughness calculated based on the second derivative of the introduced function (defined across the entire range of values), and is defined as:

$$PEN_2(x) = \int [D^2 x(s)]^2 ds \quad (\text{Eq. 13})$$

By using the *penalized sum of squared errors* (PENSSE), the function goodness of fit, as well as its roughness are considered simultaneously to identify an appropriate smooth function. Larger values of λ results in marked penalty amounts for SSE, and in this way more emphasis must be given to function smoothness rather than goodness of fit. As such, when λ goes to infinity the smoothed function (*i. e.* $x(t)$) approaches the standard linear regression, whereas when λ goes to zero, there is nothing to penalize the SSE for, and as a result, $x(t)$ is just an interpolant to the data.

The subsequent step was to identify an appropriate smoothing parameter that refrains excessive roughness while still capturing the noticeable properties of the underlying function. In this study, the *generalized cross-validation* (GCV) method (Golub, Heath and Wahba, 1979) was used to choose the tuning functions, with the following specification:

$$GCV(\lambda) = \left(\frac{n}{n-df(\lambda)} \right) \left(\frac{SSE}{n-df(\lambda)} \right) \quad (\text{Eq. 14})$$

Once the smoothed functions were developed, the mean and confidence interval of groups of functional data, as well as the first derivatives were calculated to further investigate driver behavior in speed across various horizontal curves. The mean of functional data is simply the point-wise average of the generated functional data as:

$$\bar{x}(t) = \frac{\sum_1^n x_i(t)}{n} \quad (\text{Eq. 15})$$

Ultimately, given the variance-covariance matrix of the fitted functions as $Var(\hat{y}) = \Phi C \Sigma C^T Q^T$, the confidence interval of the group of time-series data can be computed as:

$$CI = \hat{y}(t) \pm z\alpha/2\sqrt{Var(\hat{y}(t))} \quad (\text{Eq. 16})$$

In the context of this study, deriving the patterns in the first derivative of the speed profiles was also beneficial as they exhibit where drivers begin adjusting their acceleration. As a result, similar procedures were conducted to smooth and estimate the mean acceleration function at select locations. Following section, summarizes the findings from the regression analysis, as well as the outcomes of the FDA.

6.3 Results and Discussion

Initially, a series of mixed effect linear regression models was developed to examine drivers' select speed on horizontal curves using the time-series data. Various analysis strategies were investigated to identify the most proper informative model. Table 15 presents the result of the model where segments were split into only two chunks upstream and downstream of the curve PC. Parameter estimates are provided for mean baseline speed at each speed limit, as well as the associated reduction in travel speeds downstream of the PC. The impact of advisory speed signs was investigated by considering the difference between the posted speed limit and the advisory speed sign's message rather than the advisory message itself. Like previous analyses separate models were developed for the total sample, as well as a subset where no leading vehicle was present according to the forward video.

No significant difference was observed between the mean speeds at 55- and 50-mph posted limits where the mean speed was shown to be nearly 49 mph. Likewise, mean speeds were comparable between 40- and 45-mph limits where less than 1 mph difference was observed. Also, mean speeds were estimated approximately 36.5 and 28 mph at 35- and 30-mph limits, respectively.

Turning to the parameter of interest, interestingly, the associated reductions in travel speeds were found to be much lower than the suggested amount by the advisory speed sign. For example, speeds were reduced by 3.5 and 2.8 mph when reductions of 25 and 20 mph were introduced, respectively. The parameter estimates were found to be relatively similar between 20 and 15 mph reductions, as well as 10 and 5 mph reductions. These estimates are all relative to the curves where no advisory speeds were installed. Despite these comparably small estimates, it is essential to note that they were all found to be statistically significant at a 95-percent confidence interval.

In addition to both regulatory and advisory speeds, a few other variables were shown to impact drivers' select speed. Like past analyses, speeds were reduced where leading vehicles were present and under adverse weather condition. Travel speeds were reduced by approximately 1 and 3.7 mph under rainy and snowy weather, respectively. Speeds were found to be considerably different between younger and older drivers, a finding that was consistent across various other analyses.

TABLE 15. Mixed Effect Linear Regression Model for Travel Speed across Horizontal Curves – No Distance Variable Included

	Total Sample			No Leading Vehicle Sample		
Random Effects:						
Groups	Variance	Std. Dev.		Variance	Std. Dev.	
Trip ID	20.340	4.509		13.230	3.637	
Participant ID	10.390	3.224		13.310	3.648	
Location ID	23.480	4.845		23.810	4.879	
Residual:	15.190	3.898		13.420	3.663	
Fixed Effects:						
Model Term	Coeff.	Std. Err.	t-stat	Coeff.	Std. Err.	t-stat
Intercept	48.977	0.663	73.872	48.675	0.673	72.347
30-mph limit	-21.178	1.187	-17.838	-21.615	1.215	-17.787
35-mph limit	-12.121	0.973	-12.457	-11.996	0.996	-12.048
40-mph limit	-5.991	1.156	-5.183	-6.343	1.196	-5.301
45-mph limit	-5.096	0.740	-6.887	-4.824	0.733	-6.585
50-mph limit	Baseline			Baseline		
55-mph limit	Baseline			Baseline		
Advisory Sign Suggested Reduction						
No reduction (control)	Baseline			Baseline		
5-mph reduction	-0.642	0.018	-36.482	-0.708	0.024	-29.422
10-mph reduction	-1.111	0.016	-71.248	-1.766	0.020	-87.314
15-mph reduction	-2.755	0.031	-89.846	-3.790	0.037	-102.230
20-mph reduction	-2.810	0.047	-60.137	-4.046	0.052	-78.237
25-mph reduction	-3.591	0.054	-66.860	-3.898	0.062	-62.777
Degree of Curvature	-0.133	0.001	-200.233	-0.103	0.001	-137.582
No Leading Vehicle	Baseline			-		
Leading Vehicle Present	-1.273	0.188	-6.773	-		
Clear weather	Baseline			Baseline		
Rain	-1.079	0.345	-3.125	-1.040	0.427	-2.436
Snow	-3.710	1.328	-2.795	-7.526	1.748	-4.306
Age 16 to 24	1.714	0.278	6.160	2.199	0.351	6.271
Age 25 to 59	1.319	0.277	4.762	1.795	0.344	5.221
Age 60 or above	Baseline			Baseline		
Null Log-Likelihood			-4018423			-2027043
Log-Likelihood			-2576071			-1298318
Null AIC			8036875			4054113
AIC			5152181			2596884
Null BIC			8036851			4054091
BIC			5152416			2596674
Number of Observations:	922,481			Number of Observations: 475,413		
Number of Events:	3,938			Number of Events: 2,066		
Number of Participants:	1,760			Number of Participants: 1,118		
Number of Locations:	259			Number of Locations: 252		

Moreover, degree of curvature was still found to play a significant role in drivers' speed selection behavior. The associated parameter estimate was found to be lower than what was observed before which indicates that parts of such effect were captured by the variables introduced for advisory signs. However, the statistically significant impact of degree of curvature even in presence of those variables is reflective of considerable differences in the sharpness of curves with similar posted speed limit and advisory speed signs. These differences are furtherly discussed in the analysis of select location using FDA.

When comparing the two models, the total sample and the subset with no leading vehicle, a few differences stand out. First, although the mean speeds were nearly the same upstream the curve PC at each speed limit, the reductions were more pronounced when no leading vehicle was present. However, the degree of curvature parameter estimate was marginally reduced. This indicates that when no leading vehicle was present, drivers tended to adjust their speeds more based on the visual cues (i.e. curve warning and curve advisory speed signs). On the other hand, when leading vehicles were present, drivers rather moved with the flow and adjusted their speeds according to the curve sharpness as they traversed it. The parameter estimates for drivers' age and rainy weather condition remained relatively stable; however, the reductions in speeds were found to be more pronounced under snowy weather condition. This increased impact was partly because of the limited sample size available for trips under such condition.

While the previous model did provide some general insights as to how drivers adjust their speeds when traveling across horizontal curves, it did not yield into any finding as to where drivers start altering their speeds upstream of the curves and how these alterations emerge as they traverse the curves. As a result, another model was developed with an aim to gain a better understanding as to these patterns. Table 16 displays the results of this effort where the speed profiles were approximated by including a series of variables for intermediate segments upstream and downstream of the curve PC. The trips were split into smaller segments depending on their relative distance to the curve PC and PT. The parameter estimates for baseline speeds, far upstream of the curve PC, were found to be similar to those presented previously in Table 15. However, the results of the new model indicated that speed alteration begins approximately 200 ft upstream of the curve PC. In addition, it was shown that these changes do vary based on the magnitude of the suggested speed reduction. Consequently, separate variables were introduced for each individual suggested reduction. When looking at the general trends, drivers tended to reduce their speeds gradually as they approached the curve. This reduction continued as they entered the curve at higher reductions; however, drivers were found to start accelerating back to baseline speed within the curve where a 5-mph reduction was introduced. No marked changes were observed in the parameter estimates for other variables including drivers' age and weather condition.

Comparing the parameter estimates between the overall model and the subset under free flow yielded to similar findings discussed previously. For example, more pronounced reductions were found when no leading vehicle was present, whereas the impact of degree of curvature was lessened. The goodness-of-fit measures presented in Table 16 exhibit marginal improvements when compared to those of Table 15, which indicate that speed changes did occur gradually and not abruptly.

TABLE 16. Mixed Effect Linear Regression Model for Travel Speed across Horizontal Curves – Step Function

	Total Sample			No Leading Vehicle Sample		
Random Effects:						
Groups	Variance	Std. Dev.		Variance	Std. Dev.	
Trip ID	20.22	4.50		13.19	3.63	
Participant ID	10.40	3.23		13.20	3.63	
Location ID	23.24	4.82		23.37	4.83	
Residual:	15.01	3.87		13.22	3.64	
Fixed Effects:						
Model Term	Coeff.	Std. Err.	t-stat	Coeff.	Std. Err.	t-stat
Intercept	49.135	0.660	74.437	48.807	0.668	73.060
30-mph limit	-21.188	1.182	-17.928	-21.623	1.206	-17.933
35-mph limit	-12.058	0.969	-12.449	-11.952	0.988	-12.097
40-mph limit	-5.990	1.151	-5.203	-6.344	1.189	-5.336
45-mph limit	-5.108	0.736	-6.937	-4.850	0.727	-6.670
50-mph limit	Baseline			Baseline		
55-mph limit	Baseline			Baseline		
5-mph suggested reduction						
100-200 ft upstream PC	-0.331	0.033	-10.066	-0.148	0.045	-3.263
0-100 ft upstream PC	-1.064	0.030	-35.962	-0.646	0.041	-15.623
0-30 percent through curve	-1.064	0.025	-42.431	-0.785	0.035	-22.447
30-60 percent through curve	-0.947	0.025	-37.428	-1.020	0.035	-28.978
60-90 percent through curve	-0.300	0.026	-11.593	-0.548	0.036	-15.371
10-mph suggested reduction						
100-200 ft upstream PC	-0.116	0.027	-4.283	0.048	0.036	1.363
0-100 ft upstream PC	-0.601	0.025	-23.638	-0.665	0.033	-20.022
Table 17. (Continued)						
0-30 percent through curve	-0.440	0.022	-19.909	-1.003	0.029	-34.684
30-60 percent through curve	-1.204	0.023	-53.444	-1.720	0.029	-58.784
60-90 percent through curve	-1.213	0.023	-53.539	-1.796	0.029	-61.068
15-mph suggested reduction						
100-200 ft upstream PC	-1.113	0.049	-22.654	-1.326	0.059	-22.411
0-100 ft upstream PC	-3.577	0.047	-75.738	-4.427	0.056	-79.442
0-30 percent through curve	-3.094	0.045	-69.400	-4.248	0.054	-78.522
30-60 percent through curve	-3.655	0.046	-78.760	-4.963	0.056	-89.110
60-90 percent through curve	-2.854	0.048	-59.818	-4.002	0.058	-69.174
20-mph suggested reduction						
100-200 ft upstream PC	N/S			N/S		
0-100 ft upstream PC	-1.583	0.070	-22.529	-1.285	0.079	-16.233
0-30 percent through curve	-1.549	0.072	-21.526	-2.287	0.080	-28.626
30-60 percent through curve	-2.543	0.071	-35.838	-3.595	0.078	-46.118
60-90 percent through curve	-3.275	0.071	-46.231	-4.396	0.077	-57.112

25-mph suggested reduction

100-200 ft upstream PC	-2.297	0.097	-23.624	-1.657	0.115	-14.386
0-100 ft upstream PC	-6.269	0.089	-70.378	-6.414	0.103	-62.358
0-30 percent through curve	-3.525	0.078	-44.926	-3.923	0.091	-43.283
30-60 percent through curve	-3.507	0.079	-44.153	-4.152	0.092	-45.351
60-90 percent through curve	-3.597	0.075	-48.262	-3.600	0.086	-41.705
Degree of Curvature	-0.145	0.001	-	-	-	-
No Leading Vehicle	Baseline		223.690	-0.117	0.001	158.810
Leading Vehicle Present	-1.277	0.188	-6.807	-		
Clear weather	Baseline			Baseline		
Rain	-1.083	0.344	-3.146	-1.057	0.426	-2.481
Snow	-3.756	1.324	-2.836	-7.514	1.744	-4.308
Age 16 to 24	1.710	0.278	6.153	2.203	0.350	6.303
Age 25 to 59	1.322	0.277	4.778	1.803	0.343	5.259
Age 60 or above	Baseline			Baseline		
Null Log-Likelihood			-			-
			4018423			2027043
Log-Likelihood			-			-
			2570426			1294742
Null AIC			8036875			4054113
AIC			5140929			2589560
Null BIC			8036851			4054091
BIC			5141387			2589981
Number of Observations: 922,481				Number of Observations:		
				475,413		
Number of Events: 3,938				Number of Events: 2,066		
Number of Participants: 1,760				Number of Participants: 1,118		
Number of Locations: 259				Number of Locations: 252		

Although this second model was able to marginally reduce the existing heterogeneity through estimation of a step function, it was not able to provide a smooth continuous replicate of the speed profiles. In addition, as indicated by the mixed-effect linear regression models presented before, the drivers' select speeds did vary between different locations even when parameters like speed limit, advisory speed, and curve sharpness were controlled for. These limitations may be relaxed by deploying the FDA method. The FDA method provides an appropriate framework to compare the existing patterns and variations in groups of time-series data. Using this method, speed profiles were estimated as a linear combination of a series of B-spline basis functions to better examine the actual patterns in speed profiles when traversing horizontal curves. Here the results of the FDA analysis are presented for a subset of locations. These locations were selected with an aim to estimate the average driver behavior across a wide range of speed limits, advisory speeds, curves radius, and curves length.

Starting with the minimum suggested reduction, speed profiles were approximated using the FDA method for a curve posted at 35 mph with an advisory speed sign of 30 mph. The curve's

radius and curve length were 418 ft and 800 ft, respectively. First the speed profiles were examined visually. The drivers were shown to start reducing their speeds upstream of the sign with minimal deceleration as shown in Figure 24. This deceleration starts to increase as they approach the curve, especially when they were approximately 200 ft upstream of the curve PC. The absolute deceleration magnitude was highest at curve PC. Once drivers entered the curve, the reduction continued with milder rates. Ultimately, they started to accelerate back to the baseline speed after traversing approximately 25 percent of the curve.

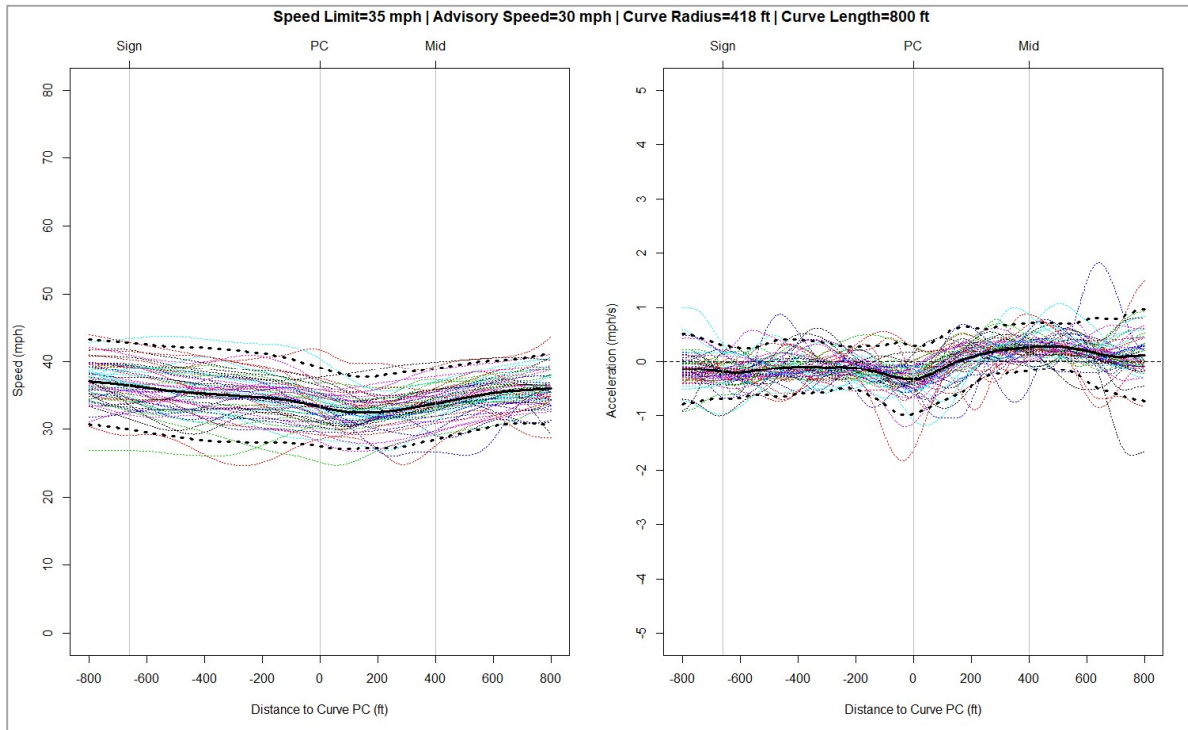

FIGURE 24 FDA Results for a Curve Posted at 35 mph and Advisory Sign of 30 mph.

To quantify the visual patterns, travel speeds were evaluated at two points upstream of the curve including the baseline travel speed upstream of the sign and at advisory speed sign location, as well as the curve PC and eight equally distant points along the curve (100 ft steps). Next, paired two-sample t-test was conducted between the speeds of each two consecutive points to discern if the observed changes were statistically significant. These results did confirm the findings from the visual inspection and are presented in Table 17. The results indicate that though drivers started reducing their speeds as soon as seeing the sign, much of speed reductions occurred between the advisory sign and the curve PC (approximately 3 mph). This reduction continued for the first 100 ft of the curve where the speeds were lowest. Approximately, 200 ft through the curve drivers were shown to start increasing their speeds. All the pairwise comparisons were found to be statistically significant under a 95 percent confidence interval except for the speeds across the first and last 200 ft of the curve where they were shown to remain stable. The lowest mean speed evaluated across this curve was 32.5 mph indicating that drivers reduced their speeds by only half of what had been suggested by the advisory sign.

TABLE 17. Paired Two-Sample t-test Results for a Curve Posted at 35 mph and Advisory Sign of 30 mph

Distance to Curve PC (ft)	Mean Speed (mph)	Mean Differences (mph)	P-Value
-800	36.997	-	-
-660	36.405	-0.592	<0.001
0	33.285	-3.120	<0.001
100	32.503	-0.782	<0.001
200	32.494	-0.008	0.947
300	32.974	0.480	<0.001
400	33.715	0.741	<0.001
500	34.557	0.842	<0.001
600	35.289	0.732	<0.001
700	35.690	0.401	0.003
800	35.961	0.271	0.07

A similar process was conducted to examine the speed profiles across other select locations. Figure 25 exhibits the results of the FDA for a curve posted at 45 mph and an advisory speed of 35 mph. The curve had a radius of 582 ft and was 820 ft long. Figure 24 illustrates the result of the FDA for this curve. A total of 47 trips were used to approximate the average drivers' select speed at this location. Similarly, speeds were shown to be reduced downstream of the sign. Unlike previous example, the reduction continued even downstream of the curve PC. Speeds were shown to be lowest approximately 200 ft past the curve PC and remained relatively consistent after. The results of the paired two-sample t-test conducted to compare the mean differences, presented in Table 18, indicate that drivers reduced their travel speeds by nearly 2.6 mph between the point they first saw the advisory sign and the curve PC. Additional reduction was observed over the first 200 ft (25 percent) of the curve and stayed stable until curve PT. Over the entire length of the curve, the minimum observed mean travel speed was approximately 39.5 mph, nearly 5 mph over the advised speed which again demonstrates that speeds were reduced by only half of the difference between speed limit and the advisory speed.

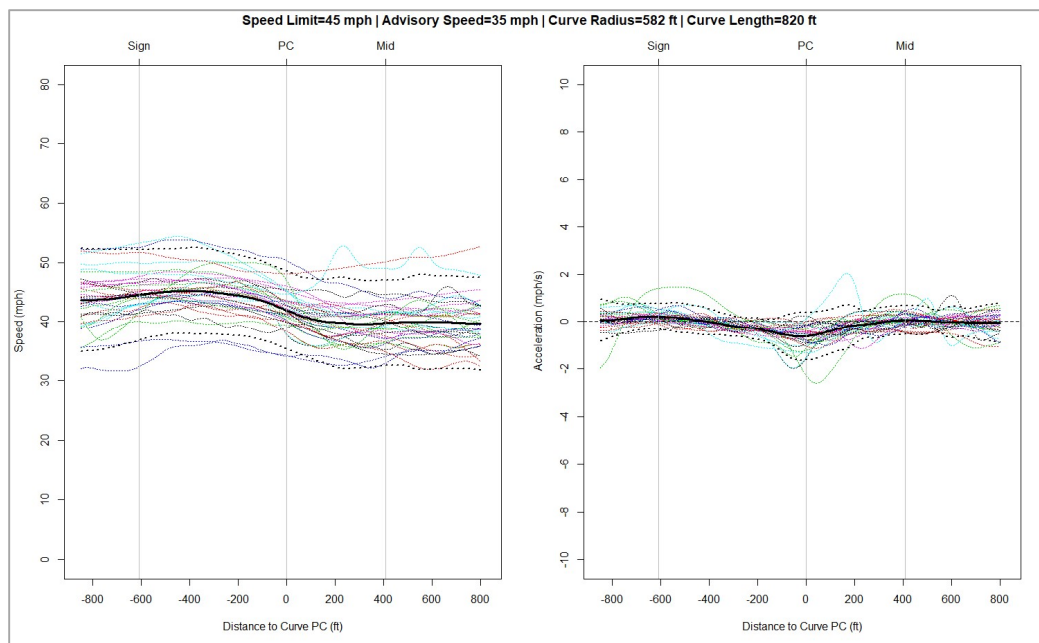

FIGURE 25 FDA Results for a Curve Posted at 45 mph and Advisory Sign of 35 mph.

TABLE 18. Paired Two-Sample t-test Results for a Curve Posted at 45 mph and Advisory Sign of 35 mph

Distance to Curve PC (ft)	Mean Speed(mph)	Mean Differences (mph)	P-Value
-850	43.64		
-610	44.52	0.88	<0.01
0	41.93	-2.59	<0.01
100	40.50	-1.44	<0.01
200	39.88	-0.62	<0.01
300	39.59	-0.28	0.06
400	39.76	0.16	0.29
500	39.92	0.16	0.33
600	39.89	-0.03	0.78
700	39.83	-0.06	0.68
800	39.67	-0.16	0.37

As for 15 mph advised reduction, speed profiles were examined across a curve with a posted limit of 55 mph and an advisory speed sign of 40 mph. The curve associated radius and length were 828 ft and 600 ft, respectively. As shown in Figure 26, functional data were smoothed for a total of 73 trips at this location. Despite the large difference between the posted speed limit and the advisory speed message, no significant reduction is evident when visually examining the mean speed profile, a finding implied by the acceleration profile, as well. To statistically confirm this, two sampled t-test was conducted, and its results are presented in Table 19.

The baseline mean speed, upstream of the sign is approximately 53 mph at posted limit of 55 mph. The speeds were shown to be reduced by only 1.5 mph over 650 ft from the advisory sign location, and curve PC. The minimal reduction in speeds continued for the first half of the curve resulting in an average speed of 50 mph which is 10 mph over the advised speed. This minimal reduction may be attributed to the large curve radius and is reflective of inconsistencies in guidelines regarding advisory speed sign installation. Past literature has generally shown drivers' sensitivity to curves to decrease as the curve radius increases where no significant alteration occurs across curves with radii around 1000 ft (Schurr et al., 2002; Wang et al., 2015).

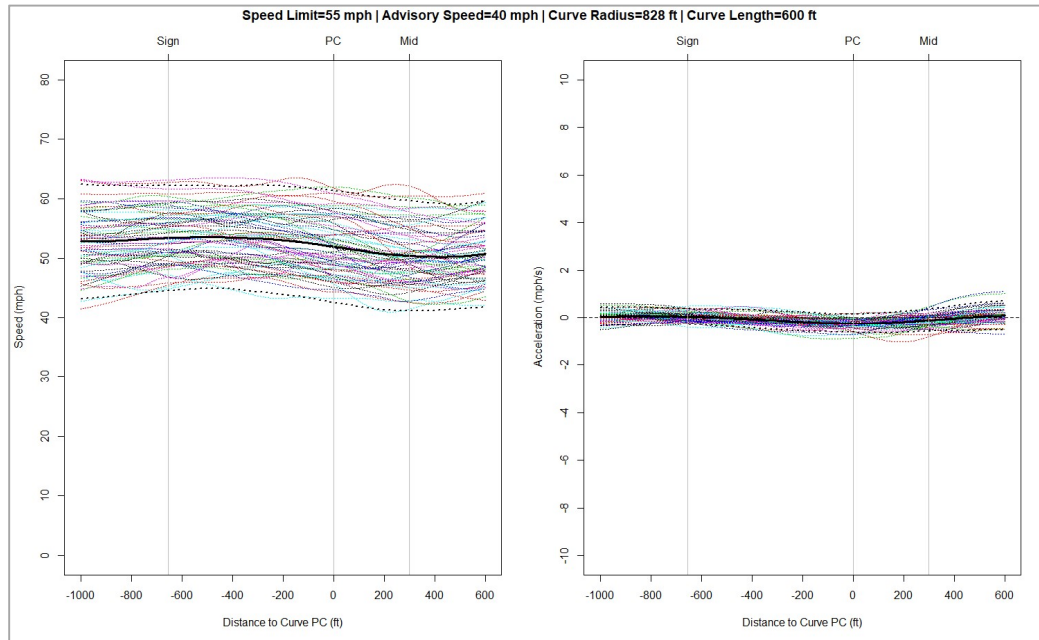

FIGURE 26 FDA Results for a Curve Posted at 55 mph and Advisory Sign of 40 mph.

TABLE 19. Paired Two-Sample t-test Results for a Curve Posted at 55 mph and Advisory Sign of 40 mph

Distance to Curve PC (ft)	Mean Speed	Mean Differences	P-Value
-1000	52.83		
-650	53.43	0.60	<0.001
0	51.97	-1.45	<0.001
100	51.34	-0.63	<0.001
200	50.75	-0.59	<0.001
300	50.43	-0.32	<0.001
400	50.26	-0.17	0.055
500	50.33	0.07	0.465
600	50.77	0.44	<0.001

The last FDA conducted as part of this study corresponded to a curve with a 45-mph limit in place, and advised speed of 20 mph. The curve was associated with a radius of 555 ft and was 410 ft long. The time-series data were obtained for a total of 28 trips along this curve. Figure 27 presents the results of the FDA for these trips where a marked reduction in travel speeds is apparent. Drivers tended to sustain their initial travel speed beyond the sign and began to reduce their speeds approximately 200 ft upstream of the curve PC. Travel speeds continued to decrease with an average deceleration of 1.5 mph/s all the way to 100 ft downstream of the curve PC. Subsequently, drivers began to accelerate and reached a stable speed around curve midpoint.

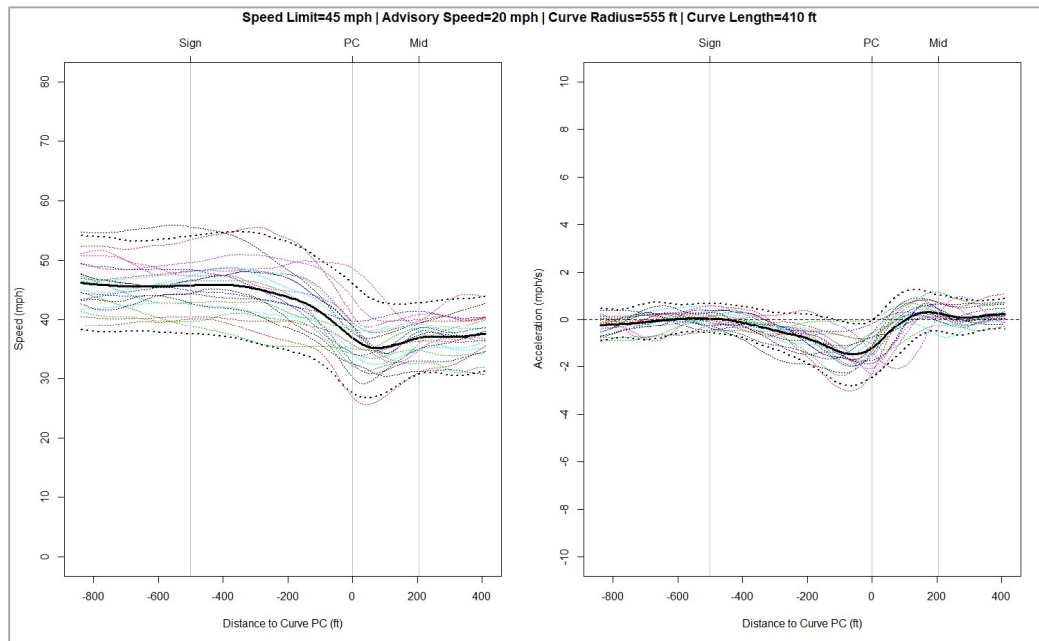

FIGURE 27 FDA Results for a Curve Posted at 45 mph and Advisory Sign of 20 mph.

To quantify the visual findings, the mean speed function was evaluated at seven points ranging from 1000 ft upstream of the PC to curve PT as shown in Table 20. The baseline mean speed at this location was around 46 mph which is comparable to the posted speed limit. No speed reduction occurred upstream of the sign; however, drivers reduced their speeds by about 9 mph between the sign’s location and the curve PC. This reduction continued for 100 ft within the curves. After this point drivers started to increase their speeds. The notable finding here is a total reduction of 12 mph over nearly 1000 ft resulting in mean speed of 35 mph within the curve which is 10 mph over the advised speed. This again confirms the previous finding that the overall reduction in travel speeds is about half of the advised reduction.

Comparing the results for these four examples indicated that drivers tended to adjust their speeds based on the associated sharpness of curves rather than the advised speed. For example, the radii for the second and the fourth curves are comparable (582 ft versus 555 ft). However, the advised speed for the first one was found to be 35 mph, whereas the second curve was associated with a 20-mph advisory speed. Despite the 15-mph difference between the two advised speeds, drivers were found to negotiate the curve similarly with nearly same travel speed across the curve.

TABLE 20. Paired Two-Sample t-test Results for a Curve Posted at 45 mph and Advisory Sign of 20 mph

Distance to Curve PC (ft)	Mean Speed (mph)	Mean Differences (mph)	P-Value
-1000	46.22	-	-
-650	45.80	-0.41	0.369
0	36.83	-8.97	<0.001
100	35.23	-1.60	<0.001
200	36.75	1.52	<0.001
300	36.97	0.23	0.47
400	37.46	0.49	0.029

In general, this section of the report provided some insights as to drivers' speed selection when traversing horizontal curves. Drivers were shown to reduce their speeds based on curve radius and in presence of advisory speeds. However, the results indicated that the advisory speeds are generally too conservative considering roadway conditions and, generally, drivers tend to drive significantly above the recommended speed.

7.0 CRASH RISKS ON FREEWAYS AND TWO-LANE HIGHWAYS

As detailed previously, one of the key benefits to the use of the SHRP2 NDS data is the inclusion of detailed data for crash, near-crash, and baseline events. Prior naturalistic driving studies have shown evidence as to importance of including such incidents as they can provide researchers with unique opportunities to investigate critical factors and behaviors pertaining to traffic safety (Dingus et al. 2006). The risk and prevalence of safety critical events including crash and near-crash incidents may be examined in consideration of drivers' behavior and attributes, environmental conditions, and roadway geometry. This can help to identify contributing factors and, subsequently, introduce solutions and potential countermeasures. Also, as the connected/autonomous vehicles (CAVs) become more popular among the public and receive greater attention from researchers, it becomes of a greater importance to know how human drivers generally behave at time of incidents to identify and plan appropriate strategies especially when mixture of conventional and CAVs are present on the road.

This section of the report examines the precipitating factors preceding crash and near-crash events. A variety of factors including driver behaviors, roadway geometry, and environmental conditions were considered. While numerous previous studies have examined the relationship between speed selection and crash risk, this study is unique in the use of high-fidelity data from the naturalistic driving study as opposed to prior research that has generally relied on police crash reports.

7.1 Data Summary

This section of the study used the event data from the SHRP2 NDS described previously. Three types of events were initially requested for analysis including crash, near-crash, and baseline events. The VTTI provided definition of crash and near-crash incidents as follows:

- **Crash:** "Any contact that the subject vehicle has with an object, either moving or fixed, at any speed in which kinetic energy is measurably transferred or dissipated is considered a crash. This also includes non-premeditated departures of the roadway where at least one tire leaves the paved or intended travel surface of the road, as well as instances where the subject vehicle strikes another vehicle, roadside barrier, pedestrian, cyclist, animal, or object on or off the roadway." (Hankey et al. 2016)
- **Near-Crash:** "Any circumstance that requires a rapid evasive maneuver by the subject vehicle, or any other vehicle, pedestrian, cyclist, or animal, to avoid a crash is considered a near-crash. A rapid evasive maneuver is defined as steering, braking, accelerating, or any combination of control inputs." (Hankey et al. 2016)

The time-series data provided by the VTTI did not include the geographic information for crashes due to confidentiality concerns. Consequently, it was not possible to extract the RID features for such events. Ultimately, the event data used in this study were comprised of only near-crash and baseline events. The summary statistics for the freeway and two-lane highway event datasets were presented previously in Table 2 and Table 3, respectively. Among freeway events, there were a total of 448 and 3,927 near-crash and baseline events, respectively. For two-

lane highways there found to be 242 near-crash and 2,659 baseline events. A variety factors including driver behavior and roadway characteristics were examined to identify those factors influencing the likelihood of involvement in near-crash events.

7.2 Statistical Methods

In addition to analyzing driver speed selection, a companion objective in this study was to assess those factors affecting crash risk. To this end, logistic regression models were estimated to examine trends in crash/near-crash involvement among study participants on both freeways and two-lane highways. Logistic regression presents an appropriate modeling framework since the dependent variable is dichotomous in nature (involvement versus non-involvement in a crash or near-crash). As describes before, near-crash incidents were used as surrogates for crashes in this study. Under the logistic regression framework, the odds of a participant being involved in a near-crash is related to a linear function of predictor variables as shown in Equation 17:

$$\log\left(\frac{p_i}{1-p_i}\right) = \beta_i X_i + \varepsilon_i \quad (\text{Eq. 17})$$

where p_i is the probability of participant i being involved in a crash or near-crash event, β_i is a vector of estimable parameters, and X_i indicates a vector of explanatory variables associated with the event outcome (e.g., driver, vehicle, roadway, and temporal characteristics), and ε_i is an error term which follows the logistic distribution.

The logistic regression model assumes that the error terms (ε_i) are independently and identically distributed (IID), which is potentially problematic as there is expected to be potential correlation in the rate of crash/near-crash events among study participants, resulting in a violation of the IID assumption. This assumption can be relaxed by adding a participant-specific parameter vector that varies randomly across drivers, similar to the approach that was utilized in the speed models discussed previously. This vector allows the constant term to vary across participants, permitting the model to capture heterogeneity that is due to other unobserved factors. Under this setting, the probability of crash or near-crash involvement is then:

$$p_i = \int \frac{\text{EXP}(\beta x_i + \varepsilon_i)}{1 + \text{EXP}(\beta x_i + \varepsilon_i)} f(\beta|\varphi) d\beta \quad (\text{Eq. 18})$$

where $f(\beta|\varphi)$ is the density function of β with φ referring to a vector of parameters of the density function (mean and variance), and all other terms as previously defined. This model structure is commonly referred to as random effects (or random intercept) logistic regression model. Following section provides the results of the logistic regression models developed for SCE analysis on freeways and two-lane highways.

7.3 Results and Discussion

Mixed-effect logistic regression models were estimated to assess factors affecting near-crash involvement on freeways and two-lane highways. Table 21 presents results of the analysis for freeway events, where positive coefficients indicate a variable is associated with a higher risk of

a near-crash while negative coefficients are indicative of conditions that are associated with lower risks.

The results show that the risk of a crash or near-crash increased significantly with increases in the standard deviation of speeds over the course of each event. The odds of a crash/near-crash increased by approximately 19.2 percent for a 1-mph increase in the standard deviation of speed during the 20-s interval. This finding is likely reflective of several factors, including greater variability in general driving speeds among crash/near-crash involved drivers, as well as the effects of other factors that may influence speeds but were not available in the analysis dataset such as the influence of other vehicles in the traffic stream. In any case, these results further demonstrate the importance of minimizing variability in travel speeds to reduce crash potential. Interestingly, mean speed and speed limit were not shown to impact crash risk directly. However, speed limit was shown to have an indirect effect through the standard deviation variable.

TABLE 21. Random Effect Logistic Regression Model for Crash/Near-Crash Risk, Freeways

Model Term	Coeff.	Std. Err.	z-stat	Pr(> z)	Odds Ratio
Intercept	-4.599	0.231	-19.865	<0.001	-
Speed std. dev.	0.176	0.024	7.39	<0.001	1.192
LOS A	Baseline				-
LOS B	1.418	0.156	9.074	<0.001	4.129
LOS C	2.29	0.208	10.984	<0.001	9.875
LOS D	3.24	0.272	11.921	<0.001	25.534
LOS E/F	2.134	0.349	6.119	<0.001	8.449
Non-junction	Baseline				-
Junction	0.63	0.129	4.896	<0.001	1.878
Non-work zone	Baseline				-
Work zone	0.487	0.277	1.76	0.078	1.627
Age 34 or less	Baseline				-
Age 35 to 74	-0.349	0.158	-2.214	0.027	0.705
Age 75 plus	Baseline				-
Null Log-Likelihood	-1445				
Log-Likelihood	-1162				
Null AIC	2892				
AIC	2345				
Null BIC	2898				
BIC	2408				
Number of Observations:	4,375				
Number of Participants:	1,975				

Turning to the other factors of interest, crash risks were highest under heavy congestion (LOS D) and particularly within work zone environments. The results indicate that presence of a work

zone increase the likelihood of involvement in a near-crash by approximately 63 percent. Likewise, near-crashes were found to be more like at junctions (i.e. interchanges) where the probability of involvement in such incidents was increased by 88 percent. Conversely, such risks were lower among drivers aged 35 to 74.

Table 22 provides the results of the similar analysis conducted using the two-lane highways event data. Crash/near-crash risk was found to be highest under moderate congestion, peaking under LOS C. This may be reflective of the fact that speeds generally decrease in a linear fashion as volumes increase on two-lane highways. Consequently, as traffic conditions approach capacity, speeds are significantly lower. This provides an explanation as to why crash risks were not significantly different between free-flow conditions (LOS A) and LOS D through F.

TABLE 22. Random Effects Logistic Regression Model for Crash/Near-Crash Risk, Two-Lane Highways

Model Term	Coeff.	Std. Err.	z-stat	Pr(> z)	Odds Ratio
Intercept	-8.967	0.492	18.231	<0.001	-
Speed std. dev.	0.145	0.04	3.574	<0.001	1.156
LOS A	Baseline				-
LOS B	1.703	0.292	5.836	<0.001	5.490
LOS C	2.574	0.727	3.542	<0.001	13.118
LOS D/E/F	Baseline				-
No access points	Baseline				-
Intersection	Baseline				-
On-street parking	-1.67	0.574	-2.909	0.003	0.188
Driveway	-0.809	0.428	-1.892	0.058	0.445
Null Log-Likelihood	-833				
Log-Likelihood	-728				
Null AIC	1667				
AIC	1470				
Null BIC	1673				
BIC	1512				
Number of Observations: 2,901					
Number of Participants: 1,593					

Interestingly, crash risks were lower where on-street parking or driveways were present, but higher at intersections and on segments with no access points. Parking may serve as a proxy for the level of development, so this finding may also be an indication of lower speeds due to increased congestion and activity levels in more urban environments. In contrast, segments that included intersections showed higher risk, which is likely reflective of increases in the number of traffic conflicts present, as well as negative impacts of the intersections on operations along the upstream segment. Surprisingly, segments with no access points also showed higher crash risk in general. In this case, it is important to note that access density is lower on higher functional class roads. Consequently, this finding could relate to other characteristics of higher class roads.

Like freeways, mean speeds and speed limits were not shown to be directly correlated with crash/near-crash involvement. However, speed standard deviation over the duration of trips was found to have a significant impact on the likelihood of near-crash occurrence. The probability of involving in a near-crash was shown to increase by nearly 16 percent for each 1-mph increase in the speed standard deviation. This impact is marginally lower than what was observed with freeways which is probably related to the lower speed limits on two-lane highways.

The analyses presented in this section of the report identified various factors that significantly impact the likelihood of near-crash involvement. The results demonstrated the importance of speeds variability in traffic safety and how fluctuations in travel speed can result in occurrence of safety critical events. Likewise, near-crash involvement was shown to be directly influenced by the level of congestion. Near-crashes were more likely under moderate to severe congestion, as well as in presence of junctions and intersections.

8.0 PREVALENCE AND IMPACTS OF DISTRACTED DRIVING

In 2015, at least 10 percent of fatal crashes, 15 percent of injury crashes, and 14 percent of all vehicular crashes were influenced by distracted driving (NHTSA, 2017). This resulted in more than 3,400 fatalities and an additional 391,000 injuries. Although distracted driving is commonly associated with the use of technologies such as cell phones, a variety of other distractions occur both inside and outside of the vehicle, including eating, conversing with passengers, and operating in-vehicle dashboard utilities (e.g., radio and navigation systems). These sources of distraction pose a significant public health risk across the United States.

Because distracted driving has been identified as a major threat to traffic safety, hundreds of research studies have been conducted to better understand the nature of those factors associated with driver inattention. The sources of distraction as well as various driver performance measures were categorized from 342 individual studies over 50 years. Ultimately, 81 percent of the analyses indicated that driver distractions degraded performance, while 16 percent noted no significant effect on performance parameters. (Atchley et al., 2016).

One of the primary contemporary concerns in this area is cell phone use by drivers. Although many states have legislation in place that prohibits cell phone usage while operating a motor vehicle, a study from NHTSA noted that 18 percent of all drivers have sent text messages or emails while driving under these regulations (Tison et al., 2011). Of those surveyed, more than half believed that using a cell phone while driving did not affect their individual driving performance, but when considering the same scenario as a passenger (i.e. riding as a passenger with a driver using their cell phone), 90 percent of the respondents noted they would feel “very unsafe” if a driver was using a handheld electronic device while driving. This overestimation of personal driving abilities and underestimating of distracted driving consequences generates an unsafe social norm, as 33 percent of young drivers (aged 18 to 24) believe that they can divert their attention from the roadway for 3 to 10 seconds before a secondary task becomes significantly dangerous.

Research by Prat et al. (2016) showed that, although drivers were aware of a ban on all cell phone-based activities, almost 44 percent admitted to texting while driving. Additionally, 32 percent admitted to talking on their device while driving. Engelberg et al. (2015) found that more than 65 percent of adults reported texting while driving and, additionally, almost 25 percent of their time while driving on the freeway was spent using a cell phone for various tasks. Another national survey of drivers showed that almost 60 percent reported texting on a cell phone within the past 30 days of taking the survey (Gliklich et al., 2016). Reading text messages (48 percent), viewing GPS navigation (43 percent), and writing text messages (33 percent) were the most frequent types of distraction. More frequent engagement in distracting behaviors was also found to be correlated with greater likelihood of crash involvement by the drivers.

Several studies have demonstrated that motorists consciously or subconsciously use compensatory behavior when engaging in a distracting behavior while driving to indirectly reduce their crash risk (Young and Regan, 2007). Some of these self-regulating behaviors include an intentional reduction in travel speed, an artificial increase in the lateral space between

their car and the car in front of them, or knowingly shifting their attention between the primary driving task and a secondary distracting task rapidly in hopes that the brief moments of inattention will be insignificant in relation to their overall driving experience.

Vieira and Larocca (2016) analyzed driver performance under distraction in a driving simulator environment. A variety of secondary tasks were performed by the participants and compared to baseline tests with no distraction present. Distracted drivers performed worse than non-distracted drivers; distracted individuals did not recognize the beginning of a curve from the same distance as they did when they were not distracted. Also, the speed at which the subjects traversed curves was much greater while engaging in the secondary tasks.

The preceding discussion illustrates the critical need for additional research into distracted driving. To this end, this chapter details a series assessments of driver distraction using observational, time-series collected as a part of the SHRP 2 NDS. This was done by leveraging the detailed information available from the NDS and the associated RID. Ultimately, three specific research questions were addressed through the resultant analyses:

- How did driver distraction affect the crash risk of motorists?
- What type of risk-taking behaviors and human characteristics made drivers more likely to engage in distracted driving activities?
- Under what roadway conditions were motorists more likely to engage in distracted driving activities?

8.1 Data Summary

All the data utilized in this analysis were obtained as a part of the SHRP2 Implementation Assistance Program (IAP). A NDS has two main advantages over traditional crash-based or operational-based analyses: (1) meticulously detailed and reviewable pre-crash information regarding the participant driver's behavior an instant before a crash occurs and (2) exposure information collected at a disaggregate level that measures the frequency and likelihood of driving behaviors and additional context of the contributing factors leading to a crash. Ultimately, the disaggregate nature of the NDS data allows for the analysis of human behavior while driving and the risk-taking tendencies of motorists, which was previously difficult to obtain using traditional data collection methods.

Driver behavioral information is critical when attempting to understand crash causal factors. Traditional methods of analysis relied on police-reported crash data, which is typically collected by an investigating officer who considered the accounts of those involved in the crash, witnesses to the crash, and the evidence available through property damage to the vehicle(s) in question, among additional considerations (i.e. tire markings, weather conditions, animal presence, etc.). These after-the-crash investigations cannot accurately determine behavior before an accident because only aggregate information is available at the time of crash documentation, as well as the personal information provided by the vehicle occupants. Because of this, there is an inherent bias when using after-the-crash data as motorists would be less likely to report inappropriate

behavior while driving, as additional charges may be associated with a crash caused due to poor operator behavior. Using NDS data, the detailed behavior of motorists was documented and confirmed in the instants immediately before a crash occurred. Driver impairment due to distraction, inattention, drowsiness, lack of judgement, or any additional human behavior characteristics was captured within the NDS framework and can be utilized in an analysis to determine future crash risk based on these disaggregate driver characteristics alone. Tracking of obvious changes in behavior, such as the utilization of a cell phone or eating while operating, was conducted by analyzing the internal video camera imagery after the data collection had completed (Campbell, 2012).

The roadway information collected by the van included:

- Number of lanes
- Lane type and width
- Grade
- Superelevation
- Beginning and ending points of horizontal curves
- Curve radius
- Paved shoulder presence and width
- Speed limit information and signage location
- Intersection locations and number of approaches
- Traffic control device locations

Based on the available disaggregate human behavior data, the accompanying risk-taking characteristics from the required personal assessment tests, and the roadway geometrics collected from the participant traveled routes, the SHRP2 program NDS supports a comprehensive assessment of how driver performance is impacted by within-vehicle behavior, motorist attributes, and roadway characteristics. The primary benefit of this extensive data repository is the ability to determine those behaviors, characteristics, and geometrics with directly impact the driving performance of the motorist.

For the purposes of these analyses, time-series data were collected from all the freeway trip events completed by the solicited participants throughout the four-year NDS data collection period. The time-series data was sampled at a rate of 10 Hz by the onboard DAS installed on participants' vehicles.

The time-series freeway trip event data was provided in 30-s intervals for crash and near-crash events, meaning that 300 observations were available for each freeway trip event that involved any type of crash or near-crash (since a measurement was taken by the DAS every decisecond), while 21-second intervals (i.e. 210 observations) were provided for non-crash events. Additionally, the provided non-crash (i.e. control) events were randomly sampled freeway trip events that did not involve any type of crash. Each freeway trip event was given a unique identification number so proper data migration could occur when considering the information observed from the onboard DAS, the results of the personal assessment tests, and the RID.

In this study, the effect of driver distraction on crash risk was analyzed. Additionally, the characteristics of drivers who were more likely to become distracted were considered in a separate analysis. Lastly, the effects of roadway parameters, such as characteristics and geometrics, were analyzed to determine their impact on the likelihood of driver distraction. To complete this analysis, the data were merged and analyzed based on the unique freeway trip event identifier previously mentioned to ensure accuracy among the three various data sources. All the video data for the NDS was analyzed and aggregated by VTTI. This included the review, analysis, and coding of the following human behavior aspects: the presence of distractions that occurred during the participant's freeway trip events, the time during which the participant was engaged and not engaged in such behavior, the answers to the personal assessment tests, and many other behavioral variables. This information was provided by VTTI to ensure that participant anonymity was maintained. Quality control procedures were also performed to ensure that the final dataset was accurate before the information was available to researchers.

Indicators were provided by VTTI to determine if the driver engaged in a distracting event during the freeway trip event. If a distraction occurred, the type of distraction was coded in the provided dataset, as was the time duration of the distraction. During the freeway trip event interval, each tenth of a second was given a corresponding identification value. Using both the unique freeway trip event indicator and the corresponding identification value of time, the interval during which the distraction event occurred was identified for further analysis purposes. After removing observations with missing data or data that could not be interpreted, the analysis datasets contained 497 participants who engaged in distracting behavior during their freeway trip events and 530 participants who did not engage in any distractions during their freeway trip events. This led to 20,571 observations in the distracted dataset, and 21,144 observations in the non-distracted dataset.

As mentioned previously, the front facing camera imagery was analyzed by VTTI researchers on a secure network to determine the exact timing of both crash and near-crash events. A crash event was denoted as any contact that a subject vehicle had with any object, whether fixed or moving (Hankey et al., 2016). This also included any non-premediated departures from the roadway. A near-crash event was any situation which required an evasive maneuver by the subject vehicle to avoid a crash (Hankey et al., 2016). Due to the similarity in the actions required by the motorist for these event types, both crash events and near-crash events were combined in the distracted and non-distracted datasets. Freeway trip events without a crash or near-crash event were classified as a non-crash (i.e. control) event for analysis comparison.

Besides the freeway trip event data that was collected, various demographic characteristics were obtained from the NDS participants through a series of surveys and interview questionnaires as mentioned previously. Before officially enrolling in the NDS, each of the participants completed a series of detailed personal assessment tests that collected various demographic information as well as tendencies and risk-taking behaviors, among other variables of interest. The participants answered a series of questions focused on their driving habits, how they performed under stressful situations, and measured their risk-taking likelihoods. The survey also documented any health impacts and medications or physical restrictions that may impair the participants from successfully enrolling in the NDS. This information was also integrated into the distracted and non-distracted datasets for each of the participants.

The RID, which contained aggregate information about the roadways traveled by the participants in all six states, provided variables related to alignment (i.e. tangent or curved surface), the number of lanes, lane width, and both left and right shoulder widths that were present during the freeway trip events. Ultimately, this information was matched with the freeway trip events for both the distracted and the non-distracted datasets. This information was included in the resultant analysis to determine the effects that roadway geometries and characteristics had on the likelihood of a driver to become distracted while operating a motor vehicle. Following the integration of the RID variables into both the distracted and non-distracted datasets, the two separate files were merged together with distraction-based binary indicators to create the dataset utilized for analysis.

The descriptive statistics of all of the variables utilized in the subsequent analyses are provided in Table 23, Table 24, Table 25, and Table 26. These tables contain the minimum, maximum, mean, and standard deviation of the time-series data, RID geometrics, driver characteristics, and driver behavioral survey results, respectively. Note that various parameters were represented using binary indicators. These variables had a zero if the parameter was not present during that time, and a one if the parameter was present during that time.

The descriptive statistics for the driver-selected speed is included in Table 23. The measured travel speed of the driver was included in the time-series information, as well as the posted speed limit of the roadway. A binary indicator was included to represent the occurrence of a crash event. The “distraction event” variable was a summation of the disaggregate distraction categories in Table 23 and identified when any type of distraction occurred during a freeway trip event. The “distraction time” characteristic noted the exact moments during the freeway trip event that a distraction occurred, if present.

TABLE 23. Descriptive Statistics of Time-Series Data

Variable	Mean	St. Dev.
Driver selected speed (mph)	51.828	18.085
Speed limit (mph)	55.456	9.328
Baseline event (0/1)	0.838	0.368
Crash or near-crash event (0/1)	0.162	0.368
Driver not distracted (0/1)	0.507	0.500
Instrument panel-related distraction (0/1)	0.022	0.146
Hygiene-related distraction (0/1)	0.025	0.155
Appearance-related distraction (0/1)	0.003	0.057
Cell phone-related distraction (0/1)	0.092	0.290
Passenger-related distraction (0/1)	0.128	0.334
Consumption-related distraction (0/1)	0.027	0.163
Smoking-related distraction (0/1)	0.010	0.102
External distraction (0/1)	0.052	0.223
Internal distraction (0/1)	0.049	0.216
Activity-related distraction (0/1)	0.084	0.278

Table 24 contains a summation of the RID geometrics, weather conditions, and traffic condition variables that were utilized in the analysis dataset. The “tangent lane type” and “curve lane type” variables were binary indicators that assumed a value of one when the horizontal alignment of interest was present (i.e. denoting when the freeway segment was tangent or curved). Note that a tangent segment is a roadway segment with a curve radius of 0°. The roadway geometrics of interest, including lane width, number of lanes, left shoulder width, and right shoulder width, were included at their per-second observation rate as well as averages over the duration of the freeway trip event. The “degree of curvature” variable was measured in degrees and had a value of zero along tangent segments. The “vertical grade” parameter was the collected percent grade from the data collection van. Lastly, the included weather and LOS parameters were binary indicators that were one when present during the freeway trip event and zero otherwise.

TABLE 24. Descriptive Statistics of RID Geometrics, Weather Conditions, and Traffic Congestion

Variable	Mean	St. Dev.
Tangent lane type (0/1)	0.686	0.464
Curve lane type (0/1)	0.314	0.464
Lane width (ft.)	11.811	2.618
Number of lanes	2.851	0.983
Left shoulder width (ft.)	4.609	3.537
Right shoulder width (ft.)	7.089	4.290
Degree of curvature (deg.)	0.676	1.936
Vertical grade (%)	0.021	1.721
Clear weather (0/1)	0.898	0.302
Light rain weather (0/1)	0.035	0.184
Rainy weather (0/1)	0.054	0.226
Foggy weather (0/1)	0.009	0.093
Rainy/foggy weather (0/1)	0.002	0.047
Snowy weather (0/1)	0.002	0.039
Level-of-service A (0/1)	0.460	0.498
Level-of-service B (0/1)	0.372	0.483
Level-of-service C (0/1)	0.097	0.296
Level-of-service D (0/1)	0.045	0.207
Level-of-service E (0/1)	0.022	0.148
Level-of-service F (0/1)	0.004	0.061

The descriptive statistics in Table 25 are all binary indicators that describe the various socioeconomic characteristics of the SHRP2 participants that were included in this analysis. As previous, the count value for each variable was the summation of the per-second observations within the time-series dataset. There was slightly more females than males and the age distribution of the operators was skewed towards the younger age categories. Most drivers had a collegiate education and a median annual income value.

TABLE 25. Descriptive Statistics of Driver Characteristics

Variable	Mean	St. Dev.
Female drivers (0/1)	0.521	0.500
Male drivers (0/1)	0.479	0.500
Driver age 16-19 (0/1)	0.041	0.198
Driver age 20-24 (0/1)	0.212	0.409
Driver age 25-29 (0/1)	0.133	0.340
Driver age 30-34 (0/1)	0.101	0.301
Driver age 35-39 (0/1)	0.054	0.225
Driver age 40-44 (0/1)	0.058	0.234
Driver age 45-49 (0/1)	0.067	0.250
Driver age 50-54 (0/1)	0.070	0.256
Driver age 55-59 (0/1)	0.075	0.263
Driver age 60-64 (0/1)	0.045	0.208
Driver age 65-69 (0/1)	0.059	0.235
Driver age 70-74 (0/1)	0.047	0.211
Driver age 75-89 (0/1)	0.039	0.195
Some high school education (0/1)	0.010	0.101
High school diploma (0/1)	0.068	0.251
Some education beyond high school (0/1)	0.239	0.427
College degree (0/1)	0.332	0.471
Some graduate school education (0/1)	0.116	0.320
Advanced degree (0/1)	0.235	0.424
Annual income under \$29,000 (0/1)	0.116	0.320
Annual income between \$30,000 and \$39,999 (0/1)	0.094	0.292
Annual income between \$40,000 and \$49,999 (0/1)	0.101	0.302
Annual income between \$50,000 and \$69,999 (0/1)	0.194	0.396
Annual income between \$70,000 and \$99,999 (0/1)	0.188	0.390
Annual income between \$100,000 and \$149,999 (0/1)	0.208	0.406
Annual income more than \$150,000 (0/1)	0.099	0.299
Average annual mileage less than 5,000 miles (0/1)	0.041	0.198
Average annual mileage between 5,000 and 10,000 miles (0/1)	0.180	0.384
Average annual mileage between 10,000 and 15,000 miles (0/1)	0.368	0.482
Average annual mileage between 15,000 and 20,000 miles (0/1)	0.174	0.379
Average annual mileage between 20,000 and 25,000 miles (0/1)	0.091	0.287
Average annual mileage between 25,000 and 30,000 miles (0/1)	0.069	0.253
Average annual mileage more than 30,000 miles (0/1)	0.077	0.267
Zero violations within the last twelve months (0/1)	0.648	0.478
One violation within the last twelve months (0/1)	0.249	0.433
Two or more violations within the last twelve months (0/1)	0.103	0.303
Zero crashes within the last twelve months (0/1)	0.718	0.450
One crash within the last twelve months (0/1)	0.226	0.418
Two or more crashes within the last twelve months (0/1)	0.057	0.231

The mileage variables represented the average annual mileage indicated by the driver before enrolling in the study. The average annual mileage category with the greatest frequency of observations was between 10,000 and 15,000. Lastly, the violation and crash parameters were a portion of the driver behavioral study in which the participant identified the number of violations and crashes they were involved in over the last twelve months before enrolling in the NDS. More than one-third (35 percent) of the operators had at least one ticketed violation, while 28 percent were involved in at least one crash.

The descriptive statistics for all of the included driver behavioral survey results are in Table 26. Note that these were also all binary indicators, similar to the characteristics included in Table 24. The parameters in Table 26 were the output of the written behavioral survey completed by all SHRP2 participants before enrolling in the program. For this portion of the survey, the participants were required to estimate how often they personally performed the behavior of interest. The options for each question were “never”, “rarely”, “sometimes”, or “often”. For this analysis, the operators who selected “never” or “rarely” were considered as non-risky motorists, as they had a lower frequency of poor roadway behavior in their past driving experiences. Conversely, operators who selected “sometimes” and “often” for the behaviors in question were considered as risky motorists, as they frequently exhibited poor roadway behavior in their past driving experiences.

The first four characteristics in Table 26 note a personal reflection on the driving abilities of the motorist. For this question, the driver rated their personal driving abilities compared to what they considered as the average driver. The remaining parameters followed the format described previously; the options for the frequency of engagement in each poor roadway behavior were “never”, “rarely”, “sometimes”, or “often”. The run red signals variables determined how frequently the operator ran red signals at intersections in their past driving experiences. The speed for fun characteristic determined the frequency the driver sped while driving for fun, while the tailgate, race drivers at green signals, accelerate at yellow signals, and road rage variables all measured the aggressiveness of the participant based on their prior driving experiences. The secondary task variable measured how often the operator admitted to performing a distracting activity while driving previously, while the race other driver’s variable measured how frequently the motorist raced other drivers in the past. The two speeding parameters in Table 26 detail how often the participant traveled ten to twenty mph over the speed limit and how often they traveled more than twenty mph over the speed limit. Lastly, the seatbelt usage characteristic estimated the frequency of seatbelt non-usage while driving.

TABLE 26. Descriptive Statistics of Driver Behavioral Survey Results

Variable	Mean	St. Dev.
Driving abilities somewhat worse than the average driver (0/1)	0.061	0.239
Driving abilities about the same as the average driver (0/1)	0.306	0.461
Driving abilities somewhat better than the average driver (0/1)	0.447	0.497
Driving abilities much better than the average driver (0/1)	0.186	0.389
Never run red signals (0/1)	0.589	0.492
Rarely run red signals (0/1)	0.386	0.487
Sometimes run red signals (0/1)	0.023	0.151
Often run red signals (0/1)	0.001	0.035
Never speed for fun (0/1)	0.813	0.390
Rarely speed for fun (0/1)	0.151	0.358
Sometimes speed for fun (0/1)	0.032	0.175
Often speed for fun (0/1)	0.004	0.065
Never tailgate (0/1)	0.500	0.500
Rarely tailgate (0/1)	0.385	0.487
Sometimes tailgate (0/1)	0.103	0.304
Often tailgate (0/1)	0.013	0.112
Never race drivers at green signal (0/1)	0.444	0.497
Rarely race drivers at green signal (0/1)	0.334	0.472
Sometimes race drivers at green signal (0/1)	0.184	0.387
Often race drivers at green signal (0/1)	0.038	0.192
Never accelerate at yellow signal (0/1)	0.151	0.358
Rarely accelerate at yellow signal (0/1)	0.509	0.500
Sometimes accelerate at yellow signal (0/1)	0.307	0.461
Often accelerate at yellow signal (0/1)	0.033	0.179
Never road rage (0/1)	0.522	0.500
Rarely road rage (0/1)	0.318	0.466
Sometimes road rage (0/1)	0.149	0.356
Often road rage (0/1)	0.012	0.107
Never perform secondary tasks (0/1)	0.092	0.289
Rarely perform secondary tasks (0/1)	0.316	0.465
Sometimes perform secondary tasks (0/1)	0.372	0.483
Often perform secondary tasks (0/1)	0.220	0.414
Never drive ten to twenty mph over the speed limit (0/1)	0.210	0.408
Rarely drive ten to twenty mph over the speed limit (0/1)	0.469	0.499
Sometimes drive ten to twenty mph over the speed limit (0/1)	0.225	0.418
Often drive ten to twenty mph over the speed limit (0/1)	0.095	0.294
Never drive more than twenty mph over the speed limit (0/1)	0.753	0.431
Rarely drive more than twenty mph over the speed limit (0/1)	0.206	0.404
Sometimes drive more than twenty mph over the speed limit (0/1)	0.037	0.188
Often drive more than twenty mph over the speed limit (0/1)	0.004	0.065
Never drive without wearing a seatbelt (0/1)	0.900	0.300
Rarely drive without wearing a seatbelt (0/1)	0.077	0.266
Sometimes drive without wearing a seatbelt (0/1)	0.015	0.123
Often drive without wearing a seatbelt (0/1)	0.008	0.089

8.2 Statistical Methods

Based on the aggregate findings from the state-of-the-art literature review, the crash risk of motorists was likely to increase when engaged in a secondary task. There may also be some roadway features that are more conducive to distracted driving opportunities and increase the likelihood of a driver to engage in a distracting task. Lastly, some specific demographic characteristics or behavioral information may be correlated with the likelihood of drivers to engage in secondary tasks. To understand these relationships, detailed driver behavioral information from the SHRP2 program NDS and corresponding RID were integrated into a distracted dataset and a non-distracted dataset, as mentioned previously. These data were carefully merged together to create one cohesive dataset after generating two separate binary indicators: (1) an indicator that identified if a freeway trip event had a distraction occur at any time during the trip event, and (2) an indicator that identified the exact time during which the distraction was occurring. Using this information, the following questions of interest were addressed:

- Under what roadway conditions were motorists more likely to engage in distracted driving activities?
- What types of drivers, in terms of demographics and risk profiles, were more likely to engage in secondary tasks?
- How did driver distraction affect the crash risk of motorists?

To examine these questions thoroughly, various regression models were estimated using the data from the SHRP 2 NDS. As mentioned previously, each of the participants in the NDS completed a series of demographic and behavioral surveys. A written driving test was also conducted that determined the participant's level of traffic knowledge. This included a risk assessment test in which the participants characterized the level of risk they associated with various poor driving behaviors. An additional portion encouraged the participant to document their likelihood of engaging in such driving behaviors and approximate the number of times they exhibited these behaviors while driving on the roadway in the past year.

By linking the well documented distraction indicators from the time-series data to the participant survey results, those solicited participants who were distracted during their recorded freeway trip events were identified. Using this information, the demographic and characteristic attributes of these participants was compared to those individuals who did not engage in a secondary task during the study period. The intent of this analysis was to determine the various attributes that increased the likelihood of a motorist to engage in a distracting activity while driving.

To this end, logistic regression models were generated that examined the documented characteristics of the study participants. A logistic regression was an appropriate framework for the corresponding survey data as the dependent variable (i.e. engaging in a secondary task while driving) was dichotomous in nature. The purpose of the model was to describe the relationship between the binary dependent variable and the significant independent explanatory variables, which described the participant's demographic characteristics and risk-taking behaviors. The assumption of the logistic regression framework was that the significant explanatory variables

directly influenced the outcome (or likelihood) of the dependent variable (i.e. engaging in a secondary task). The general form of the logistic regression model was a function of the covariates as follows:

$$Y_i = \text{logit}(P_i) = \ln\left(\frac{P_i}{1-P_i}\right) = \beta_0 + \beta_1 X_{1,i} + \beta_2 X_{2,i} + \dots + \beta_K X_{K,i} \quad (\text{Eq. 19})$$

where the dependent term, Y_i , is the logistic transformation of P_i (Karlaftis et al., 2010). P_i was the probability of a freeway trip event involving a distracting behavior. $X_{1,i}$ through $X_{K,i}$ represented explanatory variables for each specific survey response, β_0 represented a constant term, and β_1 through β_K were the parameter estimates associated with the explanatory variables.

8.3 Results and Discussion

This section details a series of analyses of the driver distraction data. Note that each of the model estimates in the upcoming tables were generated using a random effects framework; both the unique freeway trip event identifier and the unique participant identifier were included as random effects parameters. Various regression frameworks were considered to answer the three primary research questions, including linear and logistic regression models.

Numerous types of distractions occurred during the freeway events included in the analysis dataset. Because several distraction categories were infrequent, aggregate categories (that combined similar types of distractions) were created for further analysis. The types of distraction vary greatly, ranging from cell phone usage to eating without utensils; however, similar distractions were grouped together from the disaggregate categories and aggregated based on the type of action performed within the vehicle.

Table 27 contains the results of the random effects logistic regression model for any type of distraction included in the analysis. To accomplish this, a binary indicator was created that identified when any of the distractions that occurred during a freeway event. Therefore, the results reflect the conditions and types of individuals who were likely to engage in a distracting event.

Based on the statistical estimates in Table 27, both weather factors and driver behaviors and characteristics had a significant impact on the likelihood of engaging in any type of distracting activity. While driving in foggy conditions, the likelihood of a driver to engage in a distracting secondary behavior was reduced by 42 percent. Conversely, driving during clear weather conditions increased the probability of engaging in a distraction by 32 percent. Furthermore, drivers with advanced degrees (i.e. any type of graduate degree) were less likely to engage in a distraction while operating a motor vehicle. Drivers who reported being involved in two or more crashes in the previous twelve months seemed to drive more cautiously, as their likelihood of engaging in a distraction was also reduced based on the statistical estimates. After being involved in multiple crashes, drivers may experience a significant shift in their behavior while driving, which may cause them to be more cautious and take less risks during their trip events. Lastly, risk-averse drivers were less likely to engage in any type of secondary task while driving.

TABLE 27. Random effects logistic regression model for any distraction

Variable	Estimate	Std. Error	z-Value	Pr(> z)
Intercept	0.662	0.081	8.180	<0.001
Clear weather conditions (1 if yes; 0 otherwise)	0.279	0.035	8.063	<0.001
Foggy weather conditions (1 if yes; 0 otherwise)	-0.545	0.119	-4.563	<0.001
Level-of-service A (1 if yes; 0 otherwise)	0.184	0.020	9.225	<0.001
Female drivers (1 if yes; 0 otherwise)	0.181	0.020	9.056	<0.001
Advanced degree (1 if yes; 0 otherwise)	-0.315	0.024	-13.299	<0.001
Two or more violations within the last twelve months (1 if yes; 0 otherwise)	0.455	0.033	13.595	<0.001
Two or more crashes within the last twelve months (1 if yes; 0 otherwise)	-0.311	0.044	-7.146	<0.001
Never drive without wearing a seatbelt (1 if yes; 0 otherwise)	-1.125	0.075	-15.093	<0.001
Rarely drive without wearing a seatbelt (1 if yes; 0 otherwise)	-0.714	0.082	-8.672	<0.001
Modal Diagnostics				
Null deviance	57,821	DOF	41,714	
Residual deviance	56,729	DOF	41,705	
AIC	56,749			
Fisher scoring iterations	4			

There were also various traffic conditions and behavioral characteristics that increased the likelihood of a driver to perform a distracting activity. Distractions were more likely to occur during optimal LOS conditions. This finding was intuitive as less traffic is on the roadway under LOS A conditions, which may have resulted in the operators feeling more comfortable while driving and ultimately engaging in a distracting activity under conditions in which they felt were less risky. When considering the gender of the operator, female drivers were more likely to engage in a distracting behavior. Lastly, those drivers who noted that they had two or more violations within the last twelve months were 58 percent more likely to engage in a distracting secondary task. This finding presents an interesting result when compared to the crash event estimates in Table 27. Based on the statistical results, those drivers who were repeatedly cited for driving violations (i.e. risky drivers) were likely to continue exhibiting poor driving behavior, while those that were involved in multiple crash events were less likely to engage in a distracting activity.

Table 28 depicts the statistical estimates of the random effects logistic regression model for distractions related to cell phone use. Ultimately, distractions caused by cell phones were

classified as any type of interaction with a mobile electronic device while the operator was driving along the freeway. This included dialing, talking, listening, texting, or web browsing on a cell phone, as well as reaching for a phone.

TABLE 28. Random effects logistic regression model for cell phone distraction

Variable	Estimate	Std. Error	z-Value	Pr(> z)
Intercept	-1.993	0.078	-25.590	<0.001
Driver selected speed (mph)	-0.019	0.001	-21.757	<0.001
Tangent lane type (1 if yes; 0 otherwise)	0.278	0.040	7.026	<0.001
Female drivers (1 if yes; 0 otherwise)	0.470	0.036	13.029	<0.001
Average annual mileage less than 5,000 miles (1 if yes; 0 otherwise)	-0.349	0.101	-3.450	<0.001
Two or more violations within the last twelve months (1 if yes; 0 otherwise)	0.837	0.046	18.280	<0.001
Often perform secondary tasks (1 if yes; 0 otherwise)	0.806	0.037	21.785	<0.001
Never drive without wearing a seatbelt (1 if yes; 0 otherwise)	-0.177	0.053	-3.360	<0.001
Modal Diagnostics				
Null deviance	25,717	DOF	41,714	
Residual deviance	23,973	DOF	41,707	
AIC	23,989			
Fisher scoring iterations	5			

Table 29 contains the results of the random effects logistic regression model for crash risk during the freeway trip events. Using the forward facing video camera imagery, various crash categories were recorded by VTTI, including crash events and near-crash events. As mentioned previously, a near-crash is any event in which an evasive maneuver must be performed to prevent a crash from occurring. These two categories were aggregated together for the analysis of crash risk.

The results show that female drivers were less likely to be involved in a crash than their male counterparts. Furthermore, a similar trend was present between high-risk and risk-averse drivers. Risk-averse motorists were generally less likely to be crash involved, while those with a higher risk profile tended to have increased crash risks. Various other factors also increased crash risk. As the number of lanes increased, the probability of being in a crash event also increased. For every one lane increase in the roadway, the crash risk increased by 28 percent.

TABLE 29. Random effects logistic regression model for crash risk

Variable	Estimate	Std. Error	z-Value	Pr(> z)
Intercept	-2.178	0.054	-40.030	<0.001
Activity-related distraction (1 if yes; 0 otherwise)	0.492	0.046	10.595	<0.001
Hygiene-related distraction (1 if yes; 0 otherwise)	0.707	0.080	8.804	<0.001
Cell phone-related distraction (1 if yes; 0 otherwise)	1.152	0.040	28.829	<0.001
Internal distraction (1 if yes; 0 otherwise)	1.391	0.050	27.687	<0.001
Average number of lanes	0.248	0.014	17.619	<0.001
Female drivers (1 if yes; 0 otherwise)	-0.163	0.028	-5.890	<0.001
Never tailgate (1 if yes; 0 otherwise)	-0.124	0.029	-4.335	<0.001
Never race drivers at green signal (1 if yes; 0 otherwise)	-0.572	0.036	-16.103	<0.001
Rarely race drivers at green signal (1 if yes; 0 otherwise)	-0.398	0.036	-11.131	<0.001
Often road rage (1 if yes; 0 otherwise)	1.124	0.098	11.511	<0.001
Model Diagnostics				
Null deviance	36,931	DOF	41,714	
Residual deviance	34,743	DOF	41,704	
AIC	34,765			
Fisher scoring iterations	4			

Turning to the primary factor of interest, driver distraction was found to introduce a significantly higher risk of crash/near-crash involvement. Four broad categories of distraction were found to be correlated with an increase in crash risk. The odds of crash/near-crash involvement increased by 63.6 percent if the driver was involved in a general in-vehicle activity, such as singing or dancing while driving. Crash risk more than doubled if the driver was engaged in a hygiene-related activity, such as combing their hair, putting on makeup, etc. A cell phone-related distraction increased the odds of a crash or near-crash over 300 percent while another type of internal distraction, which diverted the driver’s attention entirely from the road (e.g., reaching for a cell phone, touching the radio dials) resulted in a four-fold increase in crash risk. Collectively, these statistics highlight continuing concerns with respect to the widespread use of cell phones and other forms of in-vehicle distractions by motorists.

9.0 DRIVER RESPONSE DURING CRASH/NEAR-CRASH EVENTS

Each year, more than 6 million motor vehicle crashes occur across the United States, resulting in more than 37,000 fatalities (National Center for Statistics and Analysis, 2018). Traffic crashes represent a serious public health dilemma and are among the leading causes of death, particularly among people ages 16 through 25 (Liu, Singh, & Subramanian, 2015). Research has shown the critical reason for crashes is related to the driver in more than 90 percent of all cases (Singh, 2015), highlighting the importance of better understanding the factors that precipitate crash and near-crash events. To this end, human factors, or the interaction among humans and other elements of a system, is crucial to safe driving and a critical consideration in the highway design process.

The American Association of State Highway and Transportation Officials' (AASHTO) A Policy on Geometric Design of Highway and Streets ("the Green Book") notes that human factors and driver performance are important when considering the suitability of how a highway is designed (AASHTO, 2011). A properly designed highway should be compatible with most drivers' capabilities and restrictions. The possibilities of human errors to occur increase during driving if the use of a highway is beyond a driver's abilities or if the driving environment introduces limitations to safe operation. To this end, improved comprehension of driver behavior could provide substantial benefit to the areas of roadway design and traffic safety. There are several behavioral factors that are of particular interest to highway design, including reaction time and deceleration rate.

Reaction time reflects driver responses to visual cues in the roadway environment under various circumstances. For design purposes, reaction time is defined as "the period from the time the object or condition requiring a response becomes visible in the driver's field of view to the moment of initiation of the vehicle maneuver (e.g., first contact with the brake pedal)" (Campbell et al., 2012). Average reaction time as per the AASHTO Green Book is 0.6 seconds for expected events, which increases by 35 percent for unexpected events (AASHTO, 2011).

Longer reaction time are generally associated with greater possibilities of human errors. Several factors affect reaction time, including characteristics of the driver (e.g., age, experience, familiarity), the object (contrast, object height), and the roadway environment (e.g., glare, visual complexity). There are multiple circumstances under which a driver would be expected to recognize and react to unexpected situations. For example, the driver may encounter an object in the roadway requiring a sudden stopping maneuver.

In this case, understanding drivers' braking performance is also important to roadway design. Collectively, reaction time and deceleration rate are the two critical human factors components associated with stopping sight distance. The rate of deceleration reflects driver braking performance, with the AASHTO Green Book assuming a rate of 11.2 ft/s^2 (0.35 g) for normal braking scenarios and 14.8 ft/s^2 (0.46 g) for emergency scenarios. NCHRP Report 600 suggests a value of 13.8 ft/s^2 (0.43 g) for average deceleration rate and 0.38 g for the 85th percentile deceleration rate under wet conditions with standard brakes (Campbell et al., 2012). With anti-locking brake system (ABS), the average deceleration rate is 17.1 ft/s^2 (0.53 g), and the 85th

percentile is around 14.5 ft/s² (0.45 g) on wet pavements. These typical values are based only on the underlying physics without any consideration of human factors. Although the deceleration rate or braking behavior is significantly affected by roadway surface conditions, driver characteristics may also play an important role (Campbell et al., 2012). Ultimately, both reaction time and deceleration rate play an important role in highway design as numerous elements rely on these factors, including dimensions for intersections, freeway ramps, and turnout bays for buses (AASHTO, 2011).

Examining issues such as reaction time and deceleration rate is challenging. Much of the prior research in this area has utilized traditional methods, such as driving simulator and field experiments to study driver behaviors. However, these traditional methods have several inherent limitations. For example, the use of driving simulators may not accurately reflect how drivers would respond to real-world conditions and study participant behavior may vary due to their awareness of participating in a specific experiments (Van Schagen & Sagberg, 2012). Recently, naturalistic driving studies (NDS) have introduced a promising means for overcoming these limitations. NDS generally collect data by recording real-time information on vehicle kinematics, driver behavior, and roadway information through intricate data collection equipment, including an array of video cameras and radars. These data have the potential to provide excellent insight for researchers to better understand driver performance (Van Schagen et al., 2011). NDS provide a robust method to examine research questions through the unobtrusive collection of data on driver behavior under natural conditions.

To this end, the primary objective of this study is to investigate driver behavior preceding crash and near-crash events. Of specific interest is how drivers' reaction times and deceleration rates vary under different roadway environments. The second Strategic Highway Research Program (SHRP 2) NDS dataset and the associated Roadway Information Database (RID) are used to conduct this research. These datasets provide specific information about driving behaviors, roadway characteristics, and geometrics, as well as corresponding traffic operations and environmental information.

9.1 Prior Research on Driver Response

9.1.1 Reaction Time

Reaction time is one of the critical component of determining stopping, decision, passing, and intersection sight distances (AASHTO, 2011). The AASHTO Green Book recommends a 2.5-second reaction time for stopping sight distance evaluations based upon several previous studies (Massachusetts Institute of Technology, 1935; Normann, 1953; Johansson & Rumar, 1971; Fambro et al., 1997).

Many of these early research studies estimated reaction time through field experiments or driving simulators. For example, Johansson and Rumar (1971) performed separate experiments among two groups, the first of which was required to apply the brakes under expected conditions, as well as a second group who were required to brake under both expected and unexpected

conditions. The median reaction time among the first group was 0.9 sec., which was equal to the 75th percentile in the second group.

Additionally studies have explored factors that could potentially influence reaction time such as speed, age, gender, and whether drivers were distracted or not. Olson and Sivak (1986) conducted similar experiments and measured reaction times among groups of older and younger drivers. The 95th percentile reaction times were approximately 1.6 sec. for both age groups. Higgins et al. (2017) found the median reaction time for teenagers (16 to 19 years old) was 1.36 times larger than among older drivers. Several studies have shown males to exhibit shorter reaction times than females (Der & Deary, 2006; Dane & Erzurumluoglu, 2003).

Tornros (1995) found reaction times were smaller at a lower speed (43.5 mi/h) versus a higher speed (68.4 mi/h). Dozza (2013) also found that speed influenced reaction time as higher speeds (25-45 mi/h) correlated with smaller reaction times as compared to speeds under 25 mi/h. Additionally, drivers had quicker reaction times when they encountered road departures, and sideswipe crashes, or experienced darkness.

Several recent studies have evaluated reaction times using data from naturalistic driving studies. Gao and Davis (2017) examined the impact of driver distraction on brake reaction times under car-following scenarios from 130 crash, near-crash, and crash-relevant events on freeways from the SHRP2 NDS. They found that the longer the duration of distraction for the driver, the longer their reaction time. Higgins et al. (2017) examined the influence of distraction on driver's reaction time in analyzing SHRP2 NDS data from 249 lead-vehicle or approaching-vehicle incidents involving 179 drivers. The analysis showed the median reaction time was 40.5 percent greater among drivers who were involved in visual-manual distractions; the median reaction time for crashes or near-crashes events occurred in urban area was 1.377 times longer than the events in highway or residential areas. Dozza (2013) investigated variables that impacted reaction time using data from the 100-car and 8-truck NDS. The results showed that when the drivers' eyes were off the road, reaction times were significantly greater than when focused on the road. Additionally, reaction times for distracted drivers were higher than the attentive drivers. Younger drivers showed, on average, less reaction time.

9.1.2 Deceleration Rate

There have also been various studies that have examined deceleration rates under various settings. Fambro et al. (1997), found that if drivers needed to stop for an emergency or unexpected events, or objects in their travel lanes, most of them had deceleration rates greater than 14.8 ft/s² (0.46 g). However, on wet surfaces, 90 percent of drivers decelerated at a rate about 11.2 ft/s² (0.35 g) if they were capable of staying in their driving lane and maintaining steering control during the braking maneuver. This serves as the basis for the deceleration rate of 11.2 ft/s² in the AASHTO Green Book (AASHTO, 2011).

Research by Wood and Zhang (2017) summarized findings related to deceleration rates from several previous studies (Fambro et al., 1997; Fitch et al., 2010; Paquette & Porter, 2014; Deligianni et al., 2017; Ariffin et al., 2017). Average deceleration rates ranged from 8.7 ft/s²

(0.27 g) to 24.8 ft/s² (0.77 g), with most of the deceleration rates exceeding the recommended value from AASHTO. This review also found that deceleration rates tended to be lower on curves than on tangents, as well as lower on wet versus dry pavements.

Additional research has investigated the relationship between braking performance and other characteristics. For instance, Fitch et al. (2010) used instrumented vehicles to examine deceleration rates in response to an inflatable barricade at 45 mi/h, finding strong correlation between deceleration rate and gender, age, and vehicle type. A study by Deligianni et al. (2017) investigated driver braking behaviors using NDS data from the Pan-European TeleFOT project. The results revealed the most critical factors affecting deceleration events were initial speed, distance, deceleration profile, and the reason for braking.

El-Shawarby et al. (2007) investigated braking performance at the onset of a yellow-phase transition on high-speed approaches to a signalized intersection and found deceleration rates to range from 5.0 ft/s² (0.16 g) to 24.5 ft/s² (0.76 g), with an average of 10.7 ft/s² (0.33 g). The results also indicated males decelerated at a slightly higher rate than females while drivers under 40 years old and over 59 years old had higher deceleration rates as compared to drivers ages 40 to 59. Loeb et al. (2015) also found age to be an influential factor as novice driver deceleration rates were 50 percent less on average as compared to experienced adults.

Several studies have also utilized SHRP2 NDS data. Wood and Zhang (2017) found the mean deceleration rates among crash and near-crash events to be approximately 14.2 ft/s² (0.44 g). Lindheimer et al. (2018) analyzed deceleration rates in urban corridors and compared the braking behaviors of drivers involved in crash or near-crash events with those of normal drivers. Deceleration rates ranged from 1.84 ft/s² (0.06 g) to 23.46 ft/s² (0.73), with an average rate of 8.38 ft/s² (0.26 g).

9.2 Data Summary

For the purposes of this study, kinematic data were obtained from an initial sample that included all events that occurred on freeways over the course of the NDS study that had already been reduced by VTTI. Subsequently, these events were filtered to include only crash and near-crash events.

The kinematic data, which were obtained at 10 Hz resolution by the data acquisition system (DAS) installed on the subject vehicles, included vehicle speed, acceleration, and brake pedal activation. All crash, near-crash, and crash-relevant events include 30-sec. data snapshots, which include 20 seconds prior to the precipitating event, as well as 10 sec. after the start of the event. These kinematic data were linked with data from event, driver, and vehicle tables that are publicly available through the InSight website.

These data were then integrated with roadway geometric information from the Roadway Information Database (RID), which was obtained from the Center for Transportation Research and Education (CTRE) at Iowa State University (ISU). The RID is a geospatial database that

includes roadway characteristics covering 25,000 miles of roadway where the NDS was conducted among the six study states. This includes information such as the number, type, and width of travel lanes, grade, cross-slope, horizontal and vertical curve characteristics, and the presence of lighting, barriers, rumble strips.

Ultimately, this study focused on freeways events because design standards are relatively consistent across states, traffic flow is generally uninterrupted, and there is less statistical noise associated with the vehicle kinematic data. Unfortunately, neither the NDS data nor the RID includes a field that specifies roadway functional class. Consequently, a multi-step procedure was required that involved:

1. Identifying prospective freeway events using the “Locality” field from the Event Detail table in the InSight database. The Locality type was designated as “Interstate/Bypass/Divided Highway with no traffic signals”.
2. All crash- and near-crash events that occurred along these segments were then integrated with the associated Link ID from the RID. A manual review of these segments using satellite imagery showed that a significant number of the locations were not limited access freeways.
3. A full review of the events was conducted using Google Earth after filtering the RID segments based upon speed limit (55 mph and above), number of lanes (four and above), median presence (yes), and presence of a traffic signal within 0.5 miles of either end of the event trace (no).

Once the events had been confirmed to have occurred on a freeway, they were filtered to identify those that involved braking maneuvers. This determination was made by utilizing the “V1 Evasive Maneuver” field from the Event Detail table in the InSight database. There are a total of six categories in this field that relate to braking events, which include the following:

- Braked (no lockup)
- Braked (lockup)
- Braked (lockup unknown)
- Released brakes
- Braked and steered left
- Braked and steered right

After confirming a braking event had occurred, additional events were filtered out from the dataset if they occurred under stop-and-go conditions as determined using the “Traffic Density” field from the Event Detail table in the InSight database. All cases where this field was equal to “Level-of-service F: Forced traffic flow condition with low speeds and traffic volumes that are below capacity” were removed to reduce potential biases due to periodic speed reductions under congested operations. Lastly, if an event included missing values for more than ten observations out of 300 (i.e., 1.0 s out of 30.0 s), the whole event was excluded from the dataset to ensure the completeness and accuracy of the data. When less than 1.0 s of data were missing, linear interpolation was used to impute missing values. The final dataset ultimately included a total of 159 events among 126 participants who were involved in crash or near-crash events.

9.2.1 Reaction Time Data

In order to determine reaction times, two timestamps are required from the NDS data: (1) the time at which a driver noticed an unexpected event (e.g., another vehicle braking or changing lanes, an unexpected object in the roadway); and (2) the time at which the driver started to react to this event. There are two different methods by which reaction time has been determined in prior analyses of the SHRP2 NDS data. These methods are briefly described here:

- Gao and Davis (2017) defined reaction time as the time gap between the VTTI-coded timestamp for “Event Start” and the timestamp corresponding to the point at which the driver started to react. Within the context of this study, the latter time would correspond to when the brake pedal was activated.
- Higgins et al. (2017) defined reaction time as the time gap between the VTTI-coded timestamp for “Event Start” and the timestamp for “Subject Reaction Start”.

The definition for the “Event Start” variable is “the point in the video when the sequence of events defining the occurrence of the incident, near-crash, or crash begins, Defined as the point at which the Precipitating Event (i.e., the action by the subject vehicle, another vehicle, person, animal, or non-fixed object was critical to this vehicle becoming involved in the crash or near-crash.) begins” (SHRP2 NDS, 2013). The definition for the “Subject Reaction Start” variable is the moment when drivers begin to react after they observed the incidents occurring. It was manually identified from the facial videos and recorded by the VTTI data reductionist (SHRP2 NDS, 2013). A quality assurance review was conducted to compare the timestamp for brake pedal initiation with the “Subject Reaction Start” field. In general, these timestamps were quite close to one another, though occasionally one time would occur before or after the other. Consequently, both definitions were examined as a part of this study with the Gao and Davis (2017) definition denoted as r_1 and the Higgins et al. (2017) definition denoted as r_2 .

9.2.2 Deceleration Rate Data

As in the case of reaction time, in order to determine the deceleration rate, two pieces of information are required: (1) the time at which the driver began pressing on the brake pedal (i.e., at the conclusion of interval r_1 or r_2); and (2) the time at which the vehicle reached its minimum speed (contingent on the speed occurring after the reaction time had ended).

Identifying this point required a concurrent manual review of the forward-view video and the time-series kinematic data at 10 Hz resolution. Once the initial and final speeds were confirmed, the deceleration rate was calculated based on the fundamental kinematic equation:

$$d = \frac{(v_f - v_i)}{t}, \quad (\text{Eq. 20})$$

where:

- d = deceleration rate (ft/s²)
- v_f = final travel speed when driver reached minimum speed (ft/s)
- v_i = initial travel speed when driver started braking maneuver (ft/s)
- t = time from start of braking maneuver to reach minimum speed (s)

As two reaction times were defined (r_1 and r_2), this also necessitated the calculation of two deceleration rates, which are referred to as d_1 and d_2 , respectively.

9.2.3 Descriptive Statistics

Table 30 provides summary statistics for the 159 crash and near-crash events included as a part of this investigation. Variables are aggregated based upon whether they are based on the time-series data, describe the roadway/environment, or the driver/event characteristics. For each variable, the minimum, maximum, mean, and standard deviation are provided.

Starting with the primary variables of interest, the mean values for reaction time were 1.57 seconds (r_1) and 1.46 seconds (r_2). There were a limited number of events with reaction times of 0.0 seconds where the timestamp for the “Event Start” corresponded exactly with the “Subject Reaction Start” or the time at which the brakes were applied. The maximum reaction times in the sample were 5.80 seconds. The average deceleration rates were 9.67 ft/s² (0.30 g) for d_1 and 9.40 ft/s² (0.29 g) for d_2 and the average speeds at the onset of the braking maneuver were approximately 50 mph.

Three variables were created to classify each of the crash/near-crash events based upon the precipitating factors that led to the braking maneuver. Three categories were developed, which included “rear-end conflict”, “sideswipe conflict”, and “unexpected object”. These corresponded to events in which the driver had to brake due to a lead vehicle braking in front of them, either the subject or another vehicle changing lanes and resulting in a conflict, or if an unexpected object (e.g., board, bucket) was located in the traveled way, respectively.

The other variables are broadly reflective of the distribution of events in the NDS freeway dataset with a few notable exceptions. Events were overrepresented at 60-mph speed limit, which comprised 45 percent of the sample. The NDS also oversampled among young drivers, which explains in part why 48 percent of the sample was between ages 16 and 29. There were limited instances of some scenarios, including adverse weather conditions. Lastly, only two percent of the events included crashes, with the vast majority being near-crashes. This is largely due to the fact that location data could not be provided for most of the crash events due to privacy concerns related to the personal identifying information in the NDS data.

TABLE 30. Summary Statistics for Driver Response Data

Time-Series Variables (units/values)	Min	Max	Mean	Std. Dev
Reaction time 1 (t_1) (sec.)	0.00	5.80	1.57	1.22
Reaction time 2 (t_2) (sec.)	0.00	5.55	1.46	1.27
Initial speed for d_1 (mi/h)	10.02	105.71	50.63	18.62
Initial speed for d_2 (mi/h)	6.35	101.17	49.87	19.10
Deceleration rate 1 (d_1) (ft/s ²)	0.55	31.01	9.66	5.04
Deceleration rate 2 (d_2) (ft/s ²)	0.16	27.22	9.40	4.94
Roadway/Environmental Variables (units/values)	Min	Max	Mean	Std. Dev
Lane width (ft.)	9.92	25.70	12.36	2.45
Number of lanes	1.70	6.00	3.39	0.90
Left shoulder width (ft.)	0.20	20.97	7.26	3.30
Right shoulder width (ft.)	0.25	19.23	7.53	3.08
Horizontal curve (0/1)	0.00	1.00	0.63	0.49
Degree of curve (degrees)	0.00	2.77	0.38	0.65
Grade (%)	-4.41	2.92	-0.38	1.44
55 mph speed limit (0/1)	0.00	1.00	0.27	0.45
60 mph speed limit (0/1)	0.00	1.00	0.45	0.50
65 mph speed limit (0/1)	0.00	1.00	0.13	0.34
70 mph speed limit (0/1)	0.00	1.00	0.14	0.35
Upgrade (0/1)	0.00	1.00	0.54	0.50
Downgrade (0/1)	0.00	1.00	0.46	0.50
Level-of-service A (0/1)	0.00	1.00	0.13	0.34
Level-of-service B (0/1)	0.00	1.00	0.37	0.49
Level-of-service C (0/1)	0.00	1.00	0.23	0.42
Level-of-service D (0/1)	0.00	1.00	0.18	0.39
Level-of-service E (0/1)	0.00	1.00	0.08	0.28
Clear (0/1)	0.00	1.00	0.37	0.48
Cloudy (0/1)	0.00	1.00	0.51	0.50
Fog (0/1)	0.00	1.00	0.01	0.08
Mist/light rain (0/1)	0.00	1.00	0.06	0.24
Rain and fog (0/1)	0.00	1.00	0.01	0.08
Raining (0/1)	0.00	1.00	0.04	0.21
Driver/Event Related Variables (units/values)	Min	Max	Mean	Std. Dev
Female (0/1)	0.00	1.00	0.58	0.50
Male (0/1)	0.00	1.00	0.42	0.50
Age 16 to 29 (0/1)	0.00	1.00	0.48	0.50
Age 30 to 64 (0/1)	0.00	1.00	0.43	0.50
Age 65 to 94 (0/1)	0.00	1.00	0.09	0.28
Not Distracted (0/1)	0.00	1.00	0.79	0.41
Distracted (0/1)	0.00	1.00	0.21	0.41
Crash/crash-relevant event(0/1)	0.00	1.00	0.02	0.09
Near-crash event (0/1)	0.00	1.00	0.98	0.14
Rear-end conflict (0/1)	0.00	1.00	0.59	0.49
Sideswipe conflict (0/1)	0.00	1.00	0.38	0.49
Unexpected object (0/1)	0.00	1.00	0.03	0.16
Zero violations prior to study (0/1)	0.00	1.00	0.58	0.50
One violation prior to study (0/1)	0.00	1.00	0.24	0.43
Two or more violations prior to study (0/1)	0.00	1.00	0.18	0.39

9.3 Statistical Methods

In order to better understand the mechanisms contributing to safety-critical events, a series of statistical analyses were conducted to examine various aspects of driver behavior leading up to, and during, crash and near-crash events. These analyses involved the estimation of multiple linear regression models for reaction time (r_1 and r_2) and deceleration rate (d_1 and d_2).

For analysis purposes, the 10 Hz resolution time-series data were aggregated such that each event was included once in the dataset (rather than a repeated measures setup). For time-invariant variables, such as driver age and gender, this aggregation had no impact. However, several variables changed over the course of the 30-s event. For most roadway, environmental, driver, and event related factors, the variables were typically averaged over the first 20 seconds immediately prior to the precipitating event for the crash. Some variables, such as whether or not the driver was distracted, were coded in a binary nature (equal to one if the condition occurred at any point prior to the crash/near-crash and zero otherwise).

Consequently, each observation (i.e., row in the dataset) was associated with one event. The reaction time and deceleration rate data were only obtained for those events that resulted in a crash or near-crash event. However, average travel speed and standard deviation of travel speed were examined for both crash/near-crash events, as well as normal baseline driving events. This allowed for an explicit comparison of differences in speed selection behavior between those drivers who were crash/near-crash involved and those who were not.

Each of the dependent variables noted above is essentially continuous in nature. To investigate the relationships between continuous variables and a series of independent variables of interest, ordinary least square (OLS) linear regression presents an appropriate modeling framework. The functional form (Equation 21) of the OLS linear regression model is (Washington et al., 2011):

$$Y_i = \beta_0 + \beta_1 X_1 + \beta_2 X_2 + \dots + \beta_k X_k + \varepsilon \quad (\text{Eq. 21})$$

- Y_i = Dependent variable (r_1 , r_2 , d_1 , d_2 , μ_s , or σ_s) for event i
- β_0 = Constant term (i.e., y-intercept)
- $\beta_1, \beta_2, \dots, \beta_k$ = Estimated regression coefficients for each independent variable
- $X_1 \sim X_k$ = Independent variables (e.g., driver characteristics, roadway geometry)
- ε = Normally distributed error term with mean of zero and variance of σ^2

The error term is assumed to be independently and identically distributed across events. However, one concern that arises within the context of this study is that multiple events may be correlated since several drivers had a number of different trip events in the analysis dataset. For example, one driver was shown to have a reaction time of 3.3 sec. when involved in one event, but a 4.2 sec. reaction time when involved in a second event. Likewise, the same driver decelerated at 9.29 ft/s² during the first event and 19.56 ft/s² during the second event. It is assumed that this driver may tend to react or decelerate differently (faster or slower) than other drivers due to factors that are not observed in the dataset. This would result in correlation among

events involving this same driver. For the perspective of the analysis, it was critical to account for this correlation to avoid any biased estimates for the influences of specific features (e.g., drivers' behavior and roadway characteristics) and underestimate the variability in the reaction times and deceleration rate.

To address the concern discussed before, a participant-specific intercept term was added to the model. This intercept term was used to account for the unique characteristics of individual drivers (e.g., driving styles and performance, risk perception) which were not able to be reflected by the information from NDS and RID. This term allowed the coefficient for each participant in every event to remain the same, capturing the variability in reaction times and deceleration rates. The functional equation of the model after introducing the participant-specific intercept term is given by Equation 22:

$$Y_i = \beta_0 + \beta_1 X_1 + \beta_2 X_2 + \dots + \beta_k X_k + \varepsilon + \delta \quad (\text{Eq. 22})$$

δ = A participant-specific intercept term, with a mean of zero and variance of σ^2

This model is also referred to as the random effect linear regression model. It assumes these events were a random sample from a broader driving population with the specific individual effects. As in the case of reaction time and deceleration rate, a participant-specific intercept term was also included when examining the mean speed and standard deviation in speed for events involving the same driver.

9.4 Results and Discussion

The primary goal of the study was to understand several driver behaviors by the naturalistic driving study. To do so, the freeway events from SHRP 2 NDS program and RID were analyzed by utilizing the random effect linear regression models to examine those factors related to the driver, vehicle, and roadway that influence reaction time, deceleration rate, and speed selection. The results provide insights that are valuable for improving roadway design and other traffic safety policies and programs in consideration of driver behavior under these high-risk scenarios.

9.4.1 Reaction Time

Due to the unique characteristics of the datasets, the reaction times were calculated in terms of two time periods. The first reaction time (r_1) was determined depended on the time difference between the timestamp of "Event Start" and the time point when the driver applied the brake. The distribution of r_1 is given in Figure 28. The minimum, maximum, and average values and standard deviation of r_1 were 0 sec., 5.80 sec., 1.57 sec., and 1.22 sec., respectively. The extant literature determined similar results. For example, Dozza (2013) conducted a study that showed the mean of the reaction time was 1.45 sec. for both distracted and non-distracted drivers. Another study utilized the same method to identify the reaction time indicated that the average reaction time of normal drivers was 1.58 sec. and 2.11 sec. for the distracted drivers (Gao, 2017).

The second reaction time (r_2) was calculated by directly subtracting the timestamps of “Event Start” from the timestamps of “Subject Start to React,” which were recorded by the VTTI reductionists. The distribution of r_2 is also provided in Figure 28. It displays a trend that is similar to r_1 . The histograms for both reaction times displayed right-skewed distributions. Additionally, most reaction times fell in the range of 0 to 1 sec. Only a few drivers had reaction time greater than 3 sec. Despite the similar distributions, the minimum, maximum, average values and standard deviations of r_2 were 0 sec., 5.55 sec., 1.46 sec., and 1.27 sec., respectively, which were similar to the statistics of r_1 to a great extent.

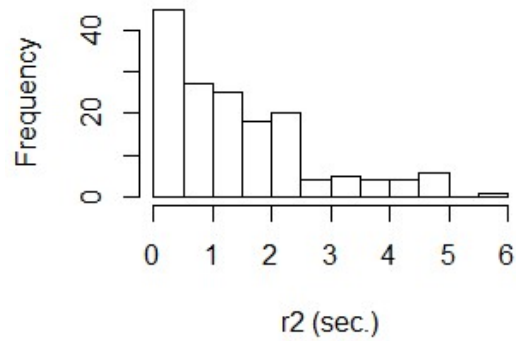
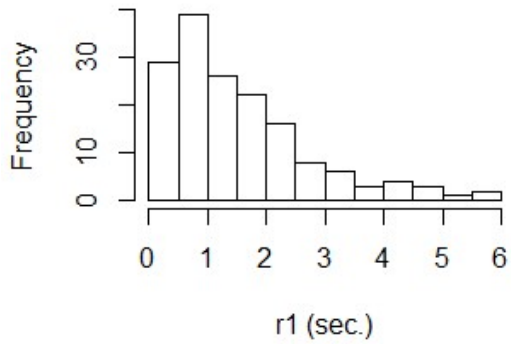

Pct.	r1 (sec.)	r2 (sec.)
0%	0.000	0.000
5%	0.290	0.083
10%	0.400	0.137
15%	0.500	0.244
20%	0.600	0.395
25%	0.700	0.477
30%	0.740	0.538
35%	0.800	0.690
40%	1.000	0.776
45%	1.100	0.999
50%	1.200	1.140
55%	1.400	1.275
60%	1.600	1.411
65%	1.700	1.744
70%	1.900	1.914
75%	2.100	2.085
80%	2.400	2.273
85%	2.700	2.513
90%	3.300	3.459
95%	4.210	4.231
100%	5.800	5.554

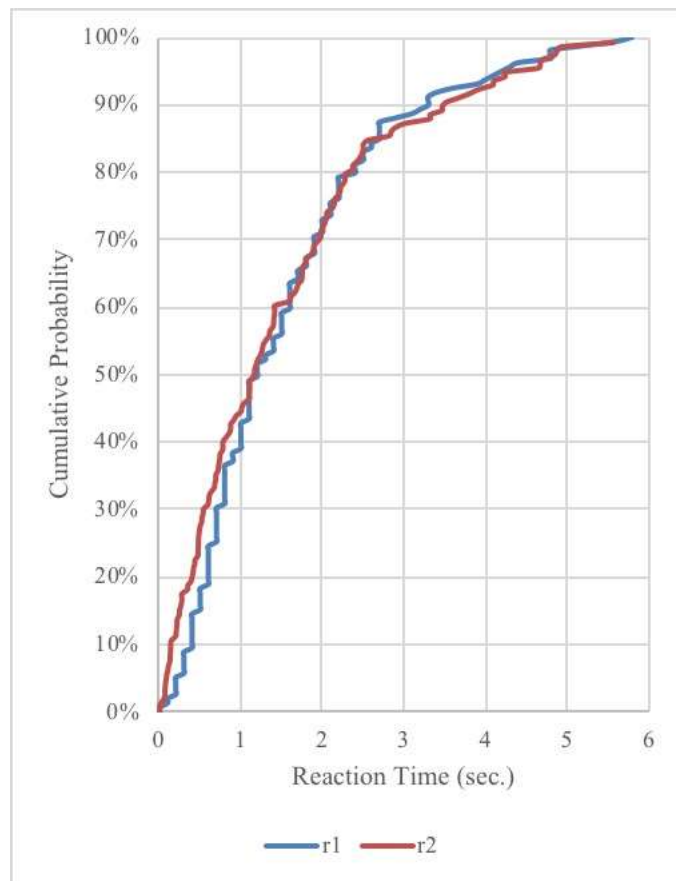

FIGURE 28 Probability Density & Cumulative Distribution Functions for Reaction Time.

In addition to descriptive statistics and distributions, cumulative distribution plots and nth percentiles were utilized to compare r_1 and r_2 as well, which are presented in Figure 28. As expected, the probability density and cumulative distribution functions for r_1 and r_2 were comparable. Moreover, Figure 28 showed that the 85th percentile reaction time was, on average, 2.60 sec. (2.70 sec. for r_1 , 2.51 sec. for r_2), which were similar with the value of 2.50 sec. indicated in several previous studies (Massachusetts Institute of Technology, 1935; Normann, 1953; Johansson & Rumar, 1971; Fambro et al., 1997). Under stopping sight situations, a 2.5 sec. reaction time reflects the capabilities of most motorists. If r_1 and r_2 were compared merely regarding data summary and distributions, there were no significant differences between r_1 and r_2 . The following sections will examine and compare the factors affecting reaction time to provide an in-depth understanding of driver's reaction time.

The 159 crash-relevant events were analyzed by the statistical model with the dependent variable of reaction time and independent variables of event-related, driver-related, and roadway geometrics-related characteristics. The results of r_1 and r_2 are provided in Table 30.

The results from Table 30 show that the type of crash/near-crash driving event (i.e., rear-end, sideswipe, or reaction to an unexpected object in the roadway), gender of the driver, and whether the driver was distracted all exhibited a statistically significant relationship with reaction time. This was true for both definitions of reaction time (r_1 and r_2) that were considered as a part of the analysis. The roadway geometrics and other roadway characteristics did not show statistically significant correlation with the reaction time in this study. This may be reflective of several factors, including the relatively homogenous nature of freeway facilities or the consistency in driving behavior on such facilities.

TABLE 30. Random Effect Linear Regression Model for the Reaction Time

Variable	Reaction time 1 (r_1)			Reaction time 2 (r_2)		
	Estimate	Std. Error	P-value	Estimate	Std. Error	P-value
(Intercept)	1.323	0.174	<0.001	1.388	0.174	<0.001
Rear-end Crashes/Near Crashes (1 if yes, 0 otherwise)	Baseline					
Sideswipe Crashes/Near Crashes (1 if yes, 0 otherwise)	-0.275	0.199	0.167	-0.588	0.205	0.005
Encounter Unexpected Objects (1 if yes, 0 otherwise)	-1.221	0.572	0.037	-1.046	0.598	0.082
Distracted Female (1 if the driver is distracted, 0 otherwise)	0.869	0.290	0.003	0.977	0.300	0.001
Distracted Male (1 if the driver is distracted, 0 otherwise)	0.939	0.356	0.009	0.574	0.364	0.117
Non-Distracted Female (1 if the driver is distracted, 0 otherwise)	Baseline					
Non-Distracted Male (1 if the driver is distracted, 0 otherwise)	0.458	0.218	0.037	0.387	0.218	0.078

Reaction times were lowest for crash/near-crash events where non-distracted female drivers encountered an unexpected object in the roadway. Reaction times varied with respect to both gender and distraction and the results varied within and across genders when considering the two different means by which reaction time was calculated.

The model result for r_1 showed drivers reacted 0.27 sec. faster if they were engaged in a sideswipe conflict, which could include another vehicle changing lanes unexpectedly (compared to the reaction time of rear-end conflicts). Drivers reacted 1.22 sec. quicker (compared to rear-end events) when they were confronted by unexpected objects in the roadway. Drivers displayed the longest reaction times when they encountered rear-end conflicts where the leading vehicle began braking. This is likely due, in part, to the fact that drivers were able to pick up on other visual cues in advance of when the leading vehicle began its braking maneuver. For example, traffic congestion upstream may lead to drivers being generally more alert in these settings. In contrast, a vehicle or an object suddenly appearing in the driver's field of view was likely to be more surprising and prompt a more aggressive response from the driver. Most drivers assume other motorists would check carefully before they change to another lane and no object would suddenly occur on the road, especially on the freeways. However, the braking of a leading vehicle would happen more frequently due to the traffic jam or other possible situations.

Of particular concern, distracted drivers responded significantly more slowly than non-distracted drivers. Overall, distracted females and males showed nearly a one-second longer response time (0.87 sec. for distracted females and 0.94 sec. for distracted males) as compared to non-distracted females. The non-distracted males reacted 0.46 sec. slower than non-distracted females. In cases of distraction, the driver's attention is not completely focused driving and the roadway environment and it would be more difficult to notice behaviors of other motorists. These results substantiate findings from previous research. Interestingly, the reaction times were almost identical for distracted females and males. However, the females showed faster reaction time than males under non-distracted situations, even though the extant literature (Der & Deary, 2006; Dane & Erzurumluoglu, 2003) suggested males generally react more quickly than females.

The results for the second reaction time variable (r_2) showed comparable findings with the first (r_1). The drivers responded slower when they confronted the vehicle braking ahead, while the drivers had shorter reaction time in situations of sideswipe crashes or near crashes, as well as unexpected objects suddenly appearing on the roads. Furthermore, the results presented that distractions increased the drivers' reaction time, and non-distracted females reacted faster than non-distracted males. The only result different from r_1 was that distracted males were related with shorter reaction times compared with distracted females. The reasons of the difference between model results of r_1 and r_2 , as well as the difference between previous work and the current study might be due to the difference in how the reaction time is determined, the fact that females had shorter reaction times under non-distracted conditions in this particular study, or the small sample size of the study. Further investigation will be conducted in the future to explore this point.

9.4.2 Deceleration Rate

To understand the braking behaviors of drivers, an investigation focused on the deceleration rates when drivers started to respond to unexpected events in crash or near-crash scenarios. The deceleration rate was calculated from the onset of the braking maneuver to the point at which the lowest speed occurred over the course of the event. Two deceleration rates were calculated, with these rates calculated at the end of reaction time 1 (r_1) and reaction time 2 (r_2). These rates are referred to as d_1 and d_2 , respectively. The distribution for d_1 is shown in Figure 6. As the data summary shows, d_1 had an average rate with standard deviation of 9.66 ft/s² (0.30 g) and 5.04 ft/s² (0.17 g), respectively. The calculated average values were marginally lower than the values reported in the previous literature. For instance, Wood and Zhang (2017) determined a mean deceleration rate of 14.17 ft/s² (0.44 g) with the standard deviation of 8.32 ft/s² (0.26 g) for the crash and near-crash events from SHRP 2 NDS dataset. These values were determined based on the data including all types of roadways and relatively higher sample size. Therefore, the deceleration rates in these studies varied from the rate of this study. Another study conducted by utilizing the SHRP 2 NDS dataset showed a lower deceleration rate compared to the current study. It showed an average deceleration rate of 8.38 ft/s² (0.26 g). This research only focused on near-crash events occurred on urban local roadways during daytime (Lindheimer et al., 2018), yet the current study focused on freeway crash and near-crash events during day and night time. Thus, the values were moderately different from d_1 .

For d_2 , the average rate and standard deviation of deceleration were 9.40 ft/s² (0.29 g) and 4.94 ft/s² (0.15 g) as summarized in Figure 29, which similar to the values shown previously for d_1 . The distribution of d_2 is also depicted in Figure 29. The histograms of two rates were similar to each other. The graphs showed the trend of normal distributions with the most values on the range of 5 ft/s² to 15 ft/s².

As with reaction time, nth percentiles and cumulative distributions were used to provide extensive comparison between d_1 and d_2 , which are included in Figure 29. The values associated with each percentile and trend of plots of d_1 and d_2 were similar with each other. Additionally, the finding of deceleration rate supported the finding from previous study. Specifically, 85th percentiles of d_1 and d_2 were comparable to the value of 14.80 ft/s² (0.46 g) in the study from Fambro et al. (1997), which was the braking rate that most drivers had when they encounter situations requiring emergency stop. More investigation regarding the deceleration rate will be introduced in the following section.

The deceleration rates were treated as the dependent variables and analyzed by the random effect linear regression model with predictors of event-related, driver-related, and roadway geometrics-related variables. Table 31 exhibits the model results of two deceleration rates.

In contrast to the reaction time analysis, the results for the two models for deceleration rate produced very consistent results. The same variables were found to be statistically significant. Furthermore, the magnitudes and signs of the estimated coefficients for each variable in the two models were close to each other, as well.

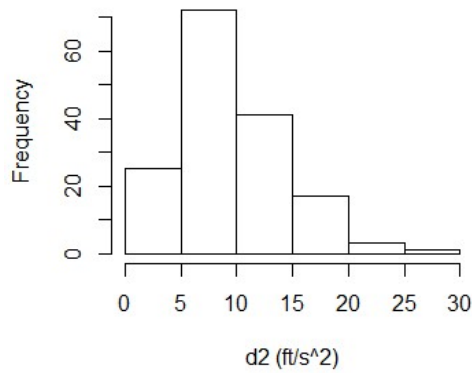
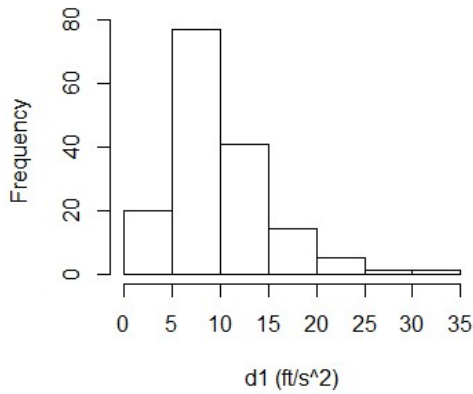

Percentile	d ₁ (ft/s ²)	d ₂ (ft/s ²)
0%	0.555	0.164
5%	2.591	2.369
10%	3.608	3.395
15%	5.248	4.612
20%	5.732	5.967
25%	7.048	6.655
30%	7.318	6.941
35%	7.673	7.311
40%	7.894	7.486
45%	8.320	8.004
50%	8.583	8.407
55%	9.352	9.103
60%	9.880	9.670
65%	10.641	10.676
70%	11.286	11.244
75%	11.962	12.094
80%	12.895	13.253
85%	14.502	14.187
90%	16.111	16.060
95%	18.993	18.118
100%	31.010	27.220

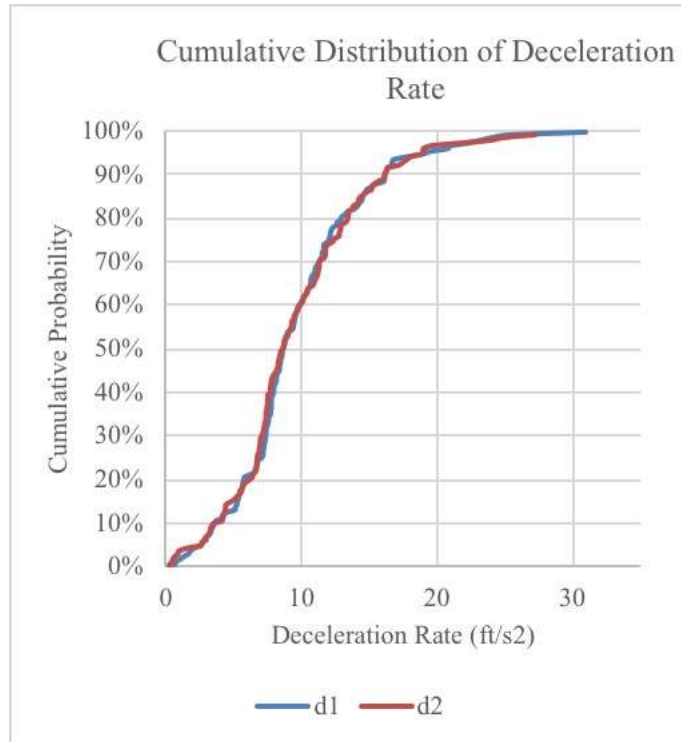

FIGURE 29 Probability Density and Cumulative Distribution Functions for Deceleration Rate.

The results indicated there was no correlation between deceleration rate and other event-related, driver-related, and roadway geometrics-related factors, except the initial speed of calculation of deceleration rate, whether the roadway was in an upgrade, and the types of crash or near crash (i.e., rear-end, sideswipe, or reaction to an unexpected object in the roadway). The initial speed was a continuous variable. As expected, vehicles with higher initial speed had a higher likelihood to decelerate slowly than vehicles with lower initial speed. This phenomenon might be caused by the natures of higher speeds and the associated driving behaviors. Specifically, the negative sign and estimated coefficient meant as the initial speed increased one mi/hr., the deceleration rate decreased 0.05 ft/s² (0.06 ft/s² for deceleration rate 2). The findings of the study supported the

results of previous studies in the literature. For example, Deligianni et al. (2017) indicated that the drivers were more likely to brake at a greater rate if the initial speed was low.

TABLE 31. Random Effect Linear Regression Model For Deceleration Rate

Description	Deceleration Rate (d ₁)			Deceleration Rate (d ₂)		
	Estimate	Std. Error	P-value	Estimate	Std. Error	P-value
(Intercept)	12.060	1.165	<0.001	12.277	1.090	<0.001
Initial Speed (mi/h)	-0.047	0.021	0.027	-0.056	0.020	0.005
Downgrade or Tangent (1 if yes, 0 otherwise)	Baseline					
Upgrade (1 if yes,0 otherwise)	2.162	0.719	0.003	2.035	0.691	0.004
Rear-end Crashes/Near Crashes (1 if yes, 0 otherwise)	Baseline					
Sideswipe Crashes/Near Crashes (1 if yes, 0 otherwise)	-3.041	0.789	<0.001	-2.983	0.765	<0.001
Encounter Unexpected Objects (1 if yes, 0 otherwise)	-4.102	2.307	0.077	-4.589	2.216	0.040

Another statistically significant factor was the upgrade roadway. Unlike the initial speed, the binary variable was created to indicate if the roadway was an uphill road or not. The negative sign and the estimated coefficient demonstrated that the vehicle was more likely to decelerate at a rate 2.16 ft/s² greater on the upgraded roadway than a vehicle deceleration rate on the downgrade or tangent roadway. The drivers generally apply brake while they are traveling on the downhill roadways for the safety purpose and accelerate on the uphill roadways to provide more tractions. Additionally, the gravity might be another significant cause of this situation. The motorists need to overcome the gravity while they traveling on an upgrade roadway. Therefore, when an unexpected event occurred and drivers traveled on an upgrade roadway, they required to brake at a higher rate.

The following factors in the Table 12 were indicator variables as well. The magnitudes and signs of estimated coefficients specified that vehicles encountering sideswipe conflicts with other vehicles or unexpected objects suddenly appearing on the roadway were associated with deceleration rates 3.04 ft/s² and 4.10 ft/s² more, when compared to vehicles observing the brake lights of leading vehicles. The drivers involved in the sideswipe crashes or near crashes were related to a lowest deceleration rate, while the drivers involved in the rear-end crashes or near-crashes had a higher likelihood to decelerate at a higher rate. This could be due to the vehicles need to fully stop to avoid the conflict with the leading vehicles in most cases, but only require slightly speed reduce to stay away from the sideswipe conflicts.

10.0 SUMMARY AND CONCLUSIONS

This study provides important insights into how drivers adapt their behavior under various roadway and environmental conditions. Time-series data from the SHRP 2 NDS were leveraged to examine how drivers adapt their speeds: 1) under constant speed limits; 2) across speed limit transition areas; and 3) along horizontal curves. These speed data were subsequently used to investigate the speed-safety relationship by examining crash/near-crash risk on both freeways and two-lane highways. The research also examined driver distraction, including the circumstances under which distraction was most prevalent, as well as the effects of distraction on crash risk. Lastly, driver behaviors were examined leading up to crash and near-crash events to assess how reaction times and deceleration rates varied among drivers involved in these safety-critical events.

Ultimately, the substantial breadth and depth of data elements available through the NDS for crash, near-crash, and baseline driving events provide a unique opportunity to identify salient factors impacting traffic safety at the level of individual drivers. The findings from this study are largely supportive of the extant research literature and identified several important considerations for transportation agencies in considering policies, programs, and countermeasures to address speed-related concerns, distracted driving, and various design issues. The following sections briefly summarize key findings of this study and discuss the resulting implications, as well as the associated limitations and potential avenues for future research.

10.1 Speed Selection under Constant Speed Limits

Drivers' speed selection behavior under constant speed limit was investigated for freeways and two-lane highways through the estimation of a series of regression models for each facility type. Unsurprisingly, higher speed limits were found to result in higher travel speeds; however, the increases in travel speeds tended to be less pronounced at higher posted limits. Drivers are generally shown to drive above the posted limit on the lower range of posted speed limits and, as limits are increased, mean speeds tend to revert nearer to the posted limit. The maximum limits at NDS sites is 70 mph, inhibiting the ability to analyze how this behavior may vary at higher limits.

In addition to responding to changes in speed limits, drivers were found to adapt their speeds based upon changes in the roadway environment, such as the introduction of horizontal curves. As noted by AASHTO (2011), travel speeds were also found to be affected by other roadway and environmental characteristics. Drivers tended to significantly reduce their speeds under congested conditions, when adverse weather conditions were present, and when encountering work zone environments. As for drivers' characteristics, it was shown that those who are under 24 tend to travel at higher speeds, whereas this impact is less pronounced for drivers between 25 and 59 (both compared to drivers who age over 60).

Beyond changes to mean speeds, the impacts of speed limits and other characteristic on the variability of travel speeds is also of particular interest. Within the context of this study, the standard deviation of speeds within individual 20-s event intervals was examined. Consequently,

this measure of variability is reflective of how drivers adapt their speeds over space and time. This variability is reflective of changes in traffic conditions, geometry, and differences in the behaviors of individual drivers.

On freeways, speeds tended to be more variable at lower posted limits, particularly at 55 and 60 mph, which is likely reflective of several factors beyond just the posted limit, such as the more urban nature of these lower speed facilities. These areas tend to have more frequent interchanges, increased levels of congestion, and may exhibit general differences in driving behavior as compared to more rural areas. The variability in travel speeds was also found to increase in the presence of congestion or work zone activities.

Likewise, speed fluctuations were generally higher at lower speed limits on two-lane highways, as well. Speed standard deviation was increased under traffic congestion, along horizontal curves, and in presence of on-street parking which all probably relates back to changes in roadway environment, and especially are indicative of more urban areas.

Ultimately, drivers select their speeds in consideration of a combination of various factors including speed limit, roadway geometry, environmental conditions, and driver behavior. The impacts of speed limits were shown to be highly variable depending upon these other factors, particularly the context of the driving environment. These findings can be used to help support policy decisions such as the establishment of maximum limits, as well as the determination as to when and where advisory speeds may be appropriate. The results also suggest contexts in which the identification of countermeasures and appropriate strategies for speed management are most needed. For example, this study demonstrated increased crash risk under variable travel speeds. As such, introducing countermeasures including speed display trailers and dynamic speed feedback signs to reduce such fluctuations may be beneficial. In addition, this study provided some evidence as to non-compliance of drivers with advisory speed signs in most cases. Consequently, revisiting the criterion for installation of such signs, as well as developing uniform guidance are warranted.

In addition, the outcomes of this study have some important implications in the area of connected and autonomous vehicles. These findings can be directly utilized in the learning stages of developing CAVs. Further, traffic engineers can benefit from the results of this study to develop traffic management strategies to overcome challenges introduced when a mixture of autonomous and conventional vehicles is present on the roads.

10.2 Speed Selection across Speed Limit Transition Areas

In addition to examining travel speeds under constant speed limits, another related item of interest was how drivers adapt their speed when the speed limit increases or decreases. As such, speed profiles were examined under a variety of transition areas, where speed limit increases and decreases occurred on both freeways and two-lane highways. Time-series data were examined from segments with 5, 10, or 15 mph increases or decreases in posted speed limits on freeways. Two-lane highways included a wider range of speed limit changes, including increases or

decreases from 5 to 20 mph. Collectively, these analyses suggest that speed changes are very gradual in the areas immediately upstream and downstream of where the posted limit changes.

For freeways, speeds were shown to marginally increase at higher speed limits. The differences between mean speeds upstream of the new regulatory speed limit were found to be much lower compared to those under constant speed limit, which is indicative of speed alterations beginning upstream of the new speed limit introduction. Speed profiles were examined for up to 1000 ft upstream of the regulatory speed sign location; however, the distance at which drivers started to alter their speeds varied significantly between locations depending on posted limit, size of limit change, and other roadway and environmental characteristics. Speeds were shown to decrease downstream of the regulatory speed sign by only 0.3 to 1.5 mph where limit reductions were introduced. Likewise, muted increases ranging from 0.7 to 1.5 mph were observed when speed limits were increased. This is true regardless of whether the magnitude of the increase or decrease in limits was 5, 10, or 15 mph. This suggests drivers are: (a) exhibiting different behaviors near these transition areas than on similar segments with constant speed limits; and (b) the actual posted limit is having minimal impact as compared to other features, such as roadway geometry and traffic density.

Similar phenomena were observed on two-lane highways. At lower speed limits, mean travel speeds were found to be significantly above the posted limit upstream of the new regulatory speed limit sign. Conversely, mean speeds over the segments upstream of the sign were shown to be markedly below the posted limit at higher limits. When speed limits increased, so did the travel speeds. Such increases ranged between 1.5 to 3 mph depending on the size of introduced limit increase. Again, the largest increases in mean speed were very small in comparison to the actual magnitude of the speed limit increases, which were as large as 20-mph in some cases. More pronounced changes were observed where limit reductions were introduced, though these decreases in mean speeds were still relatively small in consideration of the magnitude of the change in limits. For example, speeds were reduced by as much as 6 mph where reductions of 20 mph were in place. The relatively higher magnitude of reductions in mean speeds may be reflective of concerns as to speed enforcement that may occur in concurrence with these reductions, as well as more pronounced changes in roadway design. Speeds were found to be lower in presence of leading vehicles, as well as under adverse weather condition. Also, speeds were shown to reduce markedly along horizontal curves, an impact that was subsequently investigated in greater detail.

10.3 Speed Selection along Horizontal Curves

Given the impacts of horizontal alignment on travel speeds and the historical overrepresentation of crashes on horizontal curves, the final speed analyses conducted as a part of this study were focused on examining drivers' speed selection along horizontal curves, particularly those with an advisory speed signs in place. Drivers were found to reduce their speeds on curves, particularly on sharper (i.e., smaller radius) curves. These speed reductions were greater in magnitude when advisory speed signs were present. Further, the reductions were also larger in magnitude when the differences between the posted limit and the advisory speed were larger, as well. However, the reductions were found to be markedly smaller than (approximately half of) the recommended

advisory speed. This reinforces prior research literature, which has shown advisory speeds to be conservative (i.e., lower) compared to what drivers perceive as comfortable (Chowdhury et al. 1991, Bennett and Dunn 1994). Like speed limit transition areas, drivers were shown to begin reducing their speeds upstream of the indicated change point. The results demonstrated that much of the speed reduction occur between the advisory speed sign and the point of curve (PC).

Further analysis revealed that drivers tend to start accelerating back to baseline speed while within the curve when smaller differences between the posted speed limit and the advisory speed was present. Ultimately, drivers were found to adjust their speeds more based on the roadway geometry and curve radius rather than the visual cues. In addition, this study found some evidence as to inconsistencies in advisory speed sign installations across different locations, a finding supported by the past literature, as well (Ritchie, 1972).

10.4 Crash Risks on Freeways and Two-Lane Highways

Beyond establishing the relationships between various factors and driver speed selection behavior, the overarching goal is to understand how these behaviors influence the risk of a driver being involved in a crash. To this end, a series of logistic regression models were estimated to identify how speed metrics and various other factors influence crash risk. The results of this study showed that increases in the standard deviation of speeds among individual drivers significantly increases the risk of crash/near-crash events. This research showed that increases in the variability of speeds among individual drivers over time and space during 20-s event intervals led to increases in the risk of crash- or near-crash events. This is in contrast to historical research in this domain that has examined how speeds vary at individual roadway locations across different drivers over short time periods. This variability in speeds may be reflective of several factors, such as traffic congestion or differences in individual driving behaviors, which collectively contribute to an increased risk of rear-end or side-swipe collisions.

The risk of a safety-critical event was not found to vary significantly across similar highways with different posted speed limits. However, posted speed limits were found to have an indirect influence on crash risk, both on freeways and two-lane highways. For example, speed limits were shown to affect the variability in travel speeds, which in turn influenced crash risks. In addition, several other factors that are directly related to speed also impacted crash risk, including level-of-service and highway alignment. Increased crash risk was observed at junctions and intersection across freeways and two-lane highways, respectively. However, the likelihood of near-crash involvement was found to reduce in presence of driveways and on-street parking which probably relates back to lower speeds and greater level of development at such locations.

From an analysis standpoint, the random effects framework showed significant variability in speed selection and crash risk across drivers and locations. This is supported by a meta-analysis of research from Europe and the US which concludes that drivers ultimately choose their speeds based on perception of safety rather than posted speed limits (Wilmot and Khanal, 1999). These findings are largely reflective of driver opinions on speed limits, which suggests speed selection is based upon individual perceptions of what speeds are “safe”, traffic volume levels, and driving experience.

10.5 Prevalence and Impacts of Distracted Driving

This study provides important insights into driver distraction, as well as the influence of distractions on crash/near-crash risk. Driver distraction tended to be less prevalent under adverse weather conditions, as well as among certain subsets of the driving population, including those with an advanced degree, those who tended to be more risk-averse, and, interestingly, those who were involved in two or more crashes within the last twelve months. Conversely, distractions were more likely under clear weather conditions and higher levels of service (i.e., low congestion). Female drivers and those with two or more moving violations over the past 12 months were more likely to engage in distracting behaviors. Driver risk-taking behaviors and levels of risk perception were quantified through the consideration of proxy survey variables (i.e. the frequency of a motorist's prior engagements in various poor behavior activities) collected from all participants in the SHRP2 program NDS.

Risk analyses were conducted to determine which factors were likely to increase or decrease the likelihood of a crash or near-crash event among study participants based on the time-series data. From the analysis, females and risk-averse drivers were less likely to be involved in crash/near-crash events. In contrast, crashes were more likely on roadways with greater numbers of lanes, which may be reflective of the greater potential for conflicts on such facilities. Drivers who engaged in various high-risk behaviors were found to more likely to be crash-involved. The safety analyses also considered various types of distraction to identify those with the greatest associated crash risk. From the analysis, the following distraction types were associated with an increase in crash risk:

- Hygiene-related distractions
- Cell phone-related distractions
- Internal distractions
- Activity-related distractions

Of these, internal distractions increased the crash risk the most. Recall that internal distractions involved the operator reaching for or moving an item of interest in their vehicle while driving. Drivers may not consider this action as a distracting secondary task that affects their overall roadway performance; however, the results of this analysis indicated that these actions diverted their attention from the primary driving task and increased their crash risk by a factor of 3 to 4 times that of a non-distracted driver.

Based on the results of this analysis, states should consider legislation which results in a statewide ban on handheld cell phone usage for all drivers. This ban could include any type of cell phone-related distractions, including talking, texting, and browsing while driving. Although many automobile and cell phone manufacturers are currently working on integrating their technologies together to create a seamless user experience, the results of this analysis suggest that this integration should be tailored more towards reducing the number of distractions available to the driver. For example, automobile and cell phone manufacturers should limit the amount of interaction needed from the driver to use these technologies. This includes the use of device interfaces as well as voice activated commands, as both provide opportunities of

distraction for the driver. To limit the opportunities for distraction, the automobile and cell phone industries should work towards limiting device interactions for the driver while the vehicle is in motion. This would reduce the frequency of distractions available while driving to only emergency situations and remove some distracting elements that are currently available in modern vehicles, such as GPS interactions, cell phone voice commands, and integrated music control, among others.

It is also important for safety-focused transportation agencies to consider the results of this analysis, specifically the types of distractions that were prone to increase crash risk. As demonstrated by the results, several types of distractions may not be considered distracting by most motorists. Although cell phone usage is the focus of many distracted driving campaigns and the subject of modern media coverage, there are many other types of distracted driving behaviors which reduce roadway safety. By creating public awareness campaigns that broaden the focus of distracted driving from only cell phone usage to all types of distractions, including visual, manual, and cognitive activities, public education may be able to reduce the multifaceted threat that distracted driving has on modern traffic safety.

10.6 Driver Response during Crash/Near-Crash Events

This study provides important insights into driver behavior leading up to crash and near-crash events. The investigations focused on understanding how reaction time, deceleration rate, and speed selection varied with respect to traffic conditions, roadway geometry, driver characteristics, and behavioral factors. Driver response and braking behaviors were examined under unexpected situations where braking was required. The nature of the NDS data provided a unique opportunity to better understand driver performance as compared to more traditional study methods.

The participants' reaction times were determined using two different methods developed as a part of prior NDS research. In general, there was no significant difference in the summary data (mean, standard deviation, etc.) and distributions for reaction time across the two methods. The average reaction time was about 1.51 sec., with a standard deviation of 1.25 sec. and 85th percentile of 2.60 sec., which supported general findings reported in the literature. The analysis results show that reaction time varied based upon the type of crash/near-crash event, the gender of driver, and whether the driver was distracted over the course of the driving event. Particularly, the drivers were slow to respond to the braking of leading vehicles. The reaction time was longer for distracted drivers and males. Other factors such as the age of the driver, weather conditions, and the road surface showed no correlation with the reaction time. While the research literature has shown those factors to be important determinants of reaction time, it is important to note that very small samples were available for many of these areas of concern (e.g., poor weather/surface conditions, various age groups).

A second significant factor, deceleration rate, was evaluated from the end of the response time (and the start of braking) by the driver involved in the crash or near-crash event. The means and standard deviations of deceleration rates were 9.53 ft/s² (0.30 g) and 4.99 ft/s² (0.15g) respectively. In addition, the 85th percentile of deceleration rate was about 14.27 ft/s². The rates

identified in this study were comparable to the aforementioned literature values. According to the modeling results, the rate of braking was significantly affected by the initial speed of braking, the grade of the roadway, and the type of incident. The drivers had higher likelihood to brake at a greater rate if the initial speed was low, though it is unclear what explains this specific result. On an upgrade roadway or when drivers were involved in rear-end crashes or near crashes, drivers tended to decelerate more rapidly.

The findings of this study provides extensive insights into the driver's reaction and braking behavior under high-risk scenarios resulting in crash or near-crash events. These variables of interest are important from several perspectives. First, they provide insights that are useful for design practices, such as in the reliable estimation of the stopping sight distance. The results of this study help to inform the design of safer transportation systems. The results also demonstrate the negative impacts of driver distraction, particularly as it relates to delayed driver response during crash precipitating events.

10.7 Limitations

Although this study demonstrated some important insights as to drivers' speed selection under various conditions, there were some limitations associated with this study that should be noted. The available time-series data included some missing speed and location information that resulted in losing some trips. This elimination of traces impacted the associated coverage of various roadway and environmental conditions. In addition, insufficient number of trips under some of the conditions of interest resulted in the study not being able to discern the actual impact of some parameters of interest including level of service and adverse weather condition. It is also important to note that roadway, traffic, and weather conditions tended to vary across the six study states. For example, Florida and North Carolina did not have any event occurring under snowy weather condition while New York and Pennsylvania only had freeways with 55- and 60-mph limits in the study sample.

Further, no information was available as to the level and means of speed enforcements across the study locations. Another shortcoming in the SHRP 2 NDS data is the lack of information for heavy vehicles and how interactions between those and passenger cars impact travel speeds at both macro and micro level. In addition, speed selection behavior was examined and compared across different roadway segments which may potentially have some inherent differences.

For the analyses of driver distraction and pre-crash behaviors, the focus was exclusively on data collected from participants driving on freeway segments. In addition, the sample size of crash- and near-crash events was relatively small and limited by the number of such events in the NDS dataset.

10.8 Future Research

Future research is warranted to examine speed selection behavior across same roadway segments prior and after limit changes. This study assessed driver behavior using data from different

individuals and locations with similar characteristics. However, as shown by the random effects models, there might be some unobserved heterogeneity specific to locations that inhibits identifying the actual impact of different roadway and environmental characteristics on travel speeds. Consequently, examining speed profiles across same roadway segments under different conditions is suggested.

Further, the findings from this study demonstrated significant differences in speed selection behavior between different individuals. Aside from driver age, other individuals' characteristics including risk perception, mental and physical health history, driving experience and level of driving exposure need to be investigated for potential impact on speed selection behavior. Another item of interest is to examine speed profiles where differential speed limits are in place. Currently, only seven states have a differential speed limit along their roadways; however, the findings of such analysis have broader impacts as a lot of trucking companies utilize speed control devices resulting in de facto differential speeds regardless of the in-place speed limit policies. Additional research is also warranted to investigate drivers' speed selection behavior in presence of mixed traffic, and particularly heavy vehicles, and how the presence of such vehicles alters drivers' speed profiles, specifically on two-lane highways.

Also, as the transportation industry is expected to undergo significant changes in near future due to the fast-ongoing advances in automobile industry, examining drivers' behavior in consideration of their use of different levels of automation including cruise control, advanced braking systems, and more advanced technologies might be of interest. This is of great importance particularly for the transition period when a mixture of conventional and autonomous vehicles is present on the road.

11.0 REFERENCES

- Aarts, L. & I. Van Schagen (2006) Driving speed and the risk of road crashes: A review. *Accident Analysis & Prevention*, 38, 215-224.
- Aljanahi, A., A. Rhodes & A. V. Metcalfe (1999) Speed, speed limits and road traffic accidents under free flow conditions. *Accident Analysis & Prevention*, 31, 161-168.
- American Association of State Highway and Transportation Officials (2011). *A Policy on Geometric Design of Highways and Streets*. Washington, D.C.: American Association of State Highway Officials.
- Antin, J., K. Stulce, L. Eichelberger & J. Hankey. 2015. *Naturalistic Driving Study: Descriptive Comparison of the Study Sample with National Data*.
- Ariffin, A. H., Hamzah, A., Solah, M. S., & Isa, M. H. (2017). Comparative Analysis of Motorcycle Braking Performance in Emergency Situation. *Journal of the Society of Automotive Engineers Malaysia*, 137-145.
- Atchley, P., Tran, A.V., and Ali Salehinejad, M.. "Constructing a Publicly Available Distracted Driving Database and Research Tool." *Accident Analysis and Prevention*, vol. 99, 5 Dec. 2016, pp. 306-11. *Transportation Research International Documentation*. Accessed 21 Sept. 2017.
- Baum, H. M., A. K. Lund & J. K. Wells (1989) The mortality consequences of raising the speed limit to 65 mph on rural interstates. *American Journal of Public Health*, 79, 1392-1395.
- Baum, H.M., Wells, J.K. and Lund, A.K., *The Fatality Consequences of the 65 MPH Speed Limits*. *Journal of Safety Research*, Vol. 22, No. 4, pp. 171-177, 1992.
- Bennett, C. R. & R. C. Dunn (1994) Evaluation of the AUSTRROADS Horizontal Curve Design Standards for New Zealand. *Road and transport research*, 3, 54-63.
- Burritt, B. E., A. Moghrabi & J. S. Matthias (1976) Analysis of the relation of accidents and the 88-km/h (55-mph) speed limit on Arizona highways. *Transportation research record*, 609, 34-35.
- Campbell, J.L., Lichty, M.G., Brown, J.L., Richard, C.M., Graving, J.S., Graham, J., O'Laughlin, M., Torbic, D., & Harwood, D. (2012) *NCHRP Report 600: Human Factors Guidelines for Road Systems*, 2nd Edition. Washington, D.C.: National Cooperative Highway Research Program.
- Campbell, K.L. "The SHRP2 Naturalistic Driving Study: Addressing Driver Performance and Behavior in Traffic Safety." *TR News*, vol. 282, Sept. 2012, pp. 30-35.
- Chowdhury, M. A., D. L. Warren & H. Bissel (1991) Analysis of advisory speed setting criteria. *Public roads*, 55.
- Cirillo, J.A., *Interstate System Accident Research Study II, Interim Report II*. *Public Roads*, Vol. 35, No. 3, pp. 71-75, 1968.
- Dane, S., & Erzurumluoglu, A. (2003). Sex And Handedness Differences In Eye-Hand Visual Reaction Times In Handball Players. *International Journal of Neuroscience*, 113(7), 923-929. doi:10.1080/00207450390220367

- Dart Jr, O., Effects of the 88.5-KM/H (55-MPH) Speed Limit and Its Enforcement on Traffic Speeds and Accidents. Transportation Research Record No. 643: Journal of the Transportation Research Board, pp. 23-32, 1977.
- Davis, A., E. Hacker, P. T. Savolainen & T. J. Gates (2015) Longitudinal analysis of rural interstate fatalities in relation to speed limit policies. Transportation Research Record: Journal of the Transportation Research Board, 21-31.
- Deen, T.B. and Godwin, S.R., Safety Benefits of the 55 mph Speed Limit. Transportation Quarterly, Vol. 39, No. 3, 1985.
- Deligianni, S. P., Quddus, M., Morris, A., Anvuur, A., & Reed, S. (2017). Analyzing and Modeling Drivers' Deceleration Behavior from Normal Driving. Transportation Research Record: Journal of the Transportation Research Board, 2663, 134-141. doi:10.3141/2663-17
- Der, G., & Deary, I. J. (2006). Age and sex differences in reaction time in adulthood: Results from the United Kingdom Health and Lifestyle Survey. Psychology and Aging, 21(1), 62-73.
- Dingus, T. A., S. G. Klauer, V. L. Neale, A. Petersen, S. E. Lee, J. Sudweeks, M. Perez, J. Hankey, D. Ramsey & S. Gupta. 2006. The 100-car naturalistic driving study, Phase II-results of the 100-car field experiment.
- Dozza, M. (2013). What factors influence drivers' response time for evasive maneuvers in real traffic? Accident Analysis & Prevention, 58, 299-308. doi:10.1016/j.aap.2012.06.003
- El-Shawarby, I., Rakha, H., Inman, V. W., & Davis, G. W. (2007). Evaluation of Driver Deceleration Behavior at Signalized Intersections. Transportation Research Record: Journal of the Transportation Research Board, 2018(1), 29-35. doi:10.3141/2018-05
- Elvik, R. (2005) Speed and road safety: synthesis of evidence from evaluation studies. Transportation Research Record: Journal of the Transportation Research Board, 59-69.
- Emmerson, J., Speeds of Cars on Sharp Horizontal Curves. Traffic Engineering & Control, Vol. 11, No. 3, pp. 135-137, 1969.
- Engelberg, J. K., L. L. Hill, J. Rybar, and T. Styer. "Distracted Driving Behaviors Related to Cell Phone Use among Middle-Aged Adults." Journal of Transport and Health, vol. 2, 16 May 2015, pp. 434-40. Science Direct. Accessed 22 Sept. 2017.
- Fambro, D. B., K. Fitzpatrick, and R. J. Koppa. Determination of Stopping Sight Distances, NCHRP Report 400. Washington, D.C., 1997
- Farmer, C. M., R. A. Retting & A. K. Lund (1999) Changes in motor vehicle occupant fatalities after repeal of the national maximum speed limit. Accident Analysis & Prevention, 31, 537-543.
- Federal Highway Administration (2009). Manual on Uniform Traffic Control Devices. Washington, DC.
- Fildes, B., G. Rumbold & A. Leening (1991) Speed behaviour and drivers' attitude to speeding. Monash University Accident Research Centre, Report, 16, 186.
- Fitch, G. M., Blanco, M., Morgan, J. F., & Wharton, A. E. (2010). Driver Braking Performance to Surprise and Expected Events. PsycEXTRA Dataset, 2075-2080. doi:10.1037/e578852012-012

- Fitzpatrick, K., and J. M. Collins. Speed-Profile Model for Two-Lane Rural Highways. In *Transportation Research Record: Journal of the Transportation Research Board*, No. 1737, TRB, National Research Council, Washington, D.C., 2000, pp. 42–49.
- Fitzpatrick, K., Carlson, P. and Brewer, M.A., Wooldridge, M.D. and Miaou, S.P., NCHRP Report 504: Design Speed, Operating Speed, and Posted Speed Practices. Transportation Research Board, Washington, D.C., 2003.
- Forester, T.H., McNown, R.F. and Singell, L.D., A Cost-Benefit Analysis of the 55 MPH Speed Limit. *Southern Economic Journal*, Vol. 50, No. 3, pp. 631-641, 1984.
- Fowles, R. and Loeb, P.D., Speeding Coordination, and the 55 MPH Limit: Comment. *American Economic Review*, Vol. 79, No. 4, pp. 916-921, 1989.
- Freedman, M. and Esterlitz, J.R., Effect of the 65 mph Speed Limit on Speeds in Three States. *Transportation Research Record: Journal of the Transportation Research Board* No. 1281, 1990.
- Gallaher, M.M., Sewel, C.M., Flint, S., Herndon, J.L., Graff, H., Fenner, J. and Hull, H.F., Effects of the 65-MPH Speed Limit on Rural Interstate Fatalities in New Mexico. *Journal of the American Medical Association*, Vol. 262, No. 16, pp. 2243-2245, 1989.
- Gao, J., & Davis, G. A. (2017). Using naturalistic driving study data to investigate the impact of driver distraction on drivers brake reaction time in freeway rear-end events in car-following situation. *Journal of Safety Research*, 63, 195-204. doi:10.1016/j.jsr.2017.10.012
- Gao, J. "Using Naturalistic Driving Study Data to Investigate the Impact of Driver Distraction on Drivers' Reaction Time in Freeway Rear-Ending Events." *Transportation Research Circular*, vol. E-C221, May 2017, pp. 9-21. Science Direct. Accessed 22 Sept. 2017.
- Garber, N.J. and Ehrhart, A.A., Effect of Speed, Flow, and Geometric Characteristics on Crash Frequency for Two-Lane Highways. *Transportation Research Record* No. 1717: *Journal of the Transportation Research Board*, pp. 76-83, 2000.
- Gates, T.J., Savolainen, P.T., Kay, J.J., Finkelman, J. and Davis, A., Evaluating Outcomes of Raised Speed Limits on High Speed Non-Freeways. Michigan Department of Transportation, 2015.
- Glennon, J.C., Neuman, T.R. and Leisch, J.E., Safety and Operational Considerations for Design of Rural Highway Curves. Federal Highway Administration, FHWA-RD-83-035, 1983.
- Gliklich, E., R. Guo, and R. W. Bergmark. "Texting while Driving: A Study of 1,211 U.S. Adults with the Distracted Driving Survey." *Preventive Medicine Reports*, vol. 4, 6 Sept. 2016, pp. 486-89. Science Direct. Accessed 22 Sept. 2017.
- Golub, G. H., M. Heath & G. Wahba (1979) Generalized cross-validation as a method for choosing a good ridge parameter. *Technometrics*, 21, 215-223.
- Greenstone, M. (2002) A Reexamination of Resource Allocation Responses to the 65-MPH Speed Limit. *Economic Inquiry*, 40, 271-278.
- Hamzeie, R., P. T. Savolainen & T. J. Gates (2017) Driver speed selection and crash risk: insights from the naturalistic driving study. *Journal of safety research*, 63, 187-194.

- Hamzeie, R., Vafaei, B., Kay, J., Savolainen, P.T. and Gates, T.J. (2017), “A short-term evaluation of the transition from a differential to uniform speed limit for trucks and buses on two-lane highways”, *Transportation Research Record*.
- Hankey, J. M., Perez, M. A., & McClafferty, J. A. (2016). Description of the SHRP 2 Naturalistic Database and the Crash, Near-Crash, and Baseline Data Sets: Task Report(Rep.). The Strategic Highway Research Program 2 Transportation Research Board of The National Academies.
- Haselton, C.B., Gibby, A.R. and Ferrara, T.C., Methodologies Used to Analyze Collision Experience Associated with Speed Limit Changes on Selected California Highways. *Transportation Research Record No. 1784: Journal of the Transportation Research Board*, pp. 65-72, 2002.
- Higgins, L., Avelar, R., & Chrysler, S. (2017). Effects of Distraction Type, Driver Age, and Roadway Environment on Reaction Times – An Analysis Using SHRP-2 NDS Data. *Proceedings of the 9th International Driving Symposium on Human Factors in Driver Assessment, Training, and Vehicle Design: Driving Assessment 2017*.
- Hu, W. (2017) Raising the speed limit from 75 to 80 mph on Utah rural interstates: effects on vehicle speeds and speed variance, *Journal of Safety Research*, Vol. 61, 83-92.
- Johansson, G., & Rumar, K. (1971). Drivers Brake Reaction Times. *Human Factors: The Journal of the Human Factors and Ergonomics Society*,13(1), 23-27. doi:10.1177/001872087101300104
- Johnson, S. & D. Murray. 2010. Empirical analysis of truck and automobile speeds on rural interstates: Impact of posted speed limits. In *Transportation Research Board 89th Annual Meeting*.
- Kanellaidis, G., J. Golias & S. Efstathiadis (1990) Drivers' speed behaviour on rural road curves. *Traffic Engineering and Control*, 31, 414-415.
- Kockelman, K., J. Bottom, Y. Kweon, J. Ma & X. Wang. 2006. Safety impacts and other implications of raised speed limits on high-speed roads. Washington, D.C.: National Cooperative Highway Research Program, Rep. No. 17-23.
- Lamm, R. & E. M. Choueiri (1987) Recommendations for evaluating horizontal design consistency based on investigations in the state of New York. *Transportation Research Record*, 1122, 68-78.
- Lave, C. & P. Elias (1994) Did the 65 mph speed limit save lives? *Accident Analysis & Prevention*, 26, 49-62.
- Ledolter, J. & K. Chan (1996) Evaluating the impact of the 65 mph maximum speed limit on Iowa rural interstates. *The American Statistician*, 50, 79-85.
- Levy, D.T. and Asch, P., Speeding, Coordination, and the 55-MPH Limit: Comment. *American Economic Review*, Vol. 79, No. 4, pp. 913-915, 1989.
- Lindheimer, T., Avelar, R., Dastgiri, S. M., Brewer, M., & Dixon, K. (2018). Exploratory Analysis of Deceleration Rates in Urban Corridors Using SHRP-2 Data. *Transportation Research Record: Journal of the Transportation Research Board*.

- Liu, Y., Singh, S., & Subramanian, R. (2015). Motor vehicle traffic crashes as a leading cause of death in the United States, 2010 and 2011. (Traffic Safety Facts Research Note. Rep. No. DOT HS 812 203). Washington, DC: National Highway Traffic Safety Administration.
- Long, A. D., C. N. Kloeden, P. Hutchinson & J. McLean (2006) Reduction of speed limit from 110 km/h to 100 km/h on certain roads in South Australia: a preliminary evaluation.
- Lynn, C. and Jernigan, J.D., The Impact of the 65 MPH Speed Limit on Virginia's Rural Interstate Highways through 1990, Virginia Transportation Research Council, 1992.
- Mannering, F., Effects of Interstate Speed Limits on Driving Speeds: Some New Evidence. Proceedings of the Transportation Research Board 86th Annual Meeting, 2007.
- Massachusetts Institute of Technology. Report of the Massachusetts Highway Accident Survey, CWA and ERA project. Massachusetts Institute of Technology, Cambridge, MA, 1935.
- Maycock, G., P. Brocklebank & R. Hall (1998) Road layout design standards and driver behaviour. TRL REPORT 332.
- McKnight, A.J. and Klein, T.M., Relationship of 65-MPH Limit to Speeds and Fatal Accidents. Transportation Research Record No. 1281: Journal of the Transportation Research Board, pp. 71-77, 1990.
- McLaughlin, S. B. & J. M. Hankey. 2015. Naturalistic Driving Study: Linking the Study Data to the Roadway Information Database.
- McLean, J., Driver Speed Behaviour and Rural Road Alignment Design. Traffic Engineering & Control, Vol. 22, No. 4, pp. 208-211, 1981.
- Montella, A. & L. L. Imbriani (2015) Safety performance functions incorporating design consistency variables. Accident Analysis & Prevention, 74, 133-144.
- Munden, J. W. (1967) The relation between a driver's speed and his accident rate. Report LR 88. Road Research Laboratory, Crowthorne, England. 1967
- National Center for Statistics and Analysis. (2018). Early estimate of motor vehicle traffic fatalities for 2017 (Crash•Stats Brief Statistical Summary. Rep. No. DOT HS 812 542). Washington, DC: National Highway Traffic Safety Administration.
- National Highway Traffic Safety Administration. (2008) National motor vehicle crash causation survey: Report to congress. National Highway Traffic Safety Administration Technical Report DOT HS 811 059.
- National Highway Traffic Safety Administration. Traffic Safety Facts Research Note: Distracted Driving 2015. 2017. DOT HS 812 381 ed., Washington, DC, U.S. Department of Transportation, pp. 1-6. Transportation Research International Documentation. Accessed 21 Sept. 2017.
- Normann, O. K. Braking Distances of Vehicles from High Speeds. Proceedings HRB, Vol. 22. Highway Research Board, Washington, DC, 1953. pp. 421–436.
- Olson, P. L., & Sivak, M. (1986). Perception-Response Time to Unexpected Roadway Hazards. Human Factors: The Journal of the Human Factors and Ergonomics Society, 28(1), 91-96. doi:10.1177/001872088602800110
- Ossiander, E. M. & P. Cummings (2002) Freeway speed limits and traffic fatalities in Washington State. Accident Analysis & Prevention, 34, 13-18.

- Pant, P. D., J. A. Adhami & J. C. Niehaus (1992) Effects of the 65-mph speed limit on traffic accidents in Ohio. *Transportation Research Record*.
- Paquette, M., & Porter, D. (2014). Brake Timing Measurements and the Effect of Brake Lag on Deceleration Rates for Light Passenger Vehicles. *Accident Reconstruction Journal*,24(2), 19-21.
- Parker, M., Effects of Raising and Lowering Speed Limits on Selected Roadway Sections. Federal Highway Administration, 1997.
- Patterson, T.L., Frith, W.J., Poveya, L.J., and Keallaand, M.D., The Effect of Increasing Rural Interstate Speed Limits in the United States. *Traffic Injury Prevention*, Vol. 3, No. 4, pp. 316-320, 2002.
- Polus, A., Fitzpatrick, K. and Fambro, D.B., Predicting Operating Speeds on Tangent Sections of Two-Lane Rural Highways. *Transportation Research Record: Journal of the Transportation Research Board No. 1737*, pp. 50-57, 2000.
- Prat, F, M E. Gras, M Planes, S Font-Mayolas, and M.J M. Sullman. "Driving Distractions: An Insight Gained from Roadside Interview on their Prevalence and Factors Associated with Driver Distraction." *Transportation Research Part F*, vol. 45, 6 Dec. 2016, pp. 194-207. Science Direct. Accessed 22 Sept. 2017.
- Ramsay, J. O. 2006. *Functional data analysis*. Wiley Online Library.
- Ritchie, M. L. (1972) Choice of speed in driving through curves as a function of advisory speed and curve signs. *Human Factors*, 14, 533-538.
- Royal, D. (2003). Volume II – Findings, National Survey of Speeding and Unsafe Driving Attitudes and Behaviors: 2002, Washington, D.C.: National Highway Traffic Safety Administration, Rep. No. DOT HS 809 688.
- Schurr, K.S., McCoy, P.T., Pesti, G. and Huff, R., Relationship of Design, Operating, and Posted Speeds on Horizontal Curves of Rural Two-Lane Highways in Nebraska. *Transportation Research Record: Journal of the Transportation Research Board No. 1796*, pp. 60-71, 2002.
- Singh, S. (2015). Critical reasons for crashes investigated in the National Motor Vehicle Crash Causation Survey. (Traffic Safety Facts Crash•Stats. Rep. No. DOT HS 812 115). Washington, DC: National Highway Traffic Safety Administration.
- Solomon, D., Accidents on Main Rural Highways Related to Speed, Driver, and Vehicle. United States Bureau of Public Roads, Washington, D.C., 1964.
- Tison, J., Chaudhary, N., & Cosgrove, L. (2011). National Phone Survey on Distracted Driving Attitudes and Behaviors (pp. 1-104). Trumbull, CT: Preusser Research Group, Inc. Retrieved from Google (DOT HS 811 555).
- Törnros, J. (1995). Effect of driving speed on reaction time during motorway driving. *Accident Analysis & Prevention*,27(4), 435-442. doi:10.1016/0001-4575(94)00084-y
- Upchurch, J., Arizona's Experience with the 65-MPH Speed Limit. *Transportation Research Record No. 1244: Journal of the Transportation Research Board*, pp. 1-6, 1989.
- Van Schagen, I., Welsh, R., Backer-Grøndahl, A., Hoedemaeker, M., Lotan, T., Morris, A., Sagberg, F., & Winkelbauer, M. (2011). Towards a large-scale European Naturalistic Driving

study: Main findings of PROLOGUE. PROLOGUE Deliverable D4.2. SWOV Institute for Road Safety Research, Leidschendam, The Netherlands.

Van Schagen, I., & Sagberg, F. (2012). The Potential Benefits of Naturalistic Driving for Road Safety Research: Theoretical and Empirical Considerations and Challenges for the Future. *Procedia - Social and Behavioral Sciences*, 48, 692-701.

Vieira, F. S., and A. P. C. Larocca. "Drivers' Speed Profile at Curves under Distraction Task." *Transportation Research Part F*, vol. 44, 14 Oct. 2016, pp. 12-19. *Transportation Research International Documentation*. Accessed 21 Sept. 2017.

Voigt, A., Evaluation of Alternative Horizontal Curve Design Approaches on Rural Two-Lane Highways. Texas Transportation Institute, 1996.

Wagenaar, A. C., F. M. Streff & R. H. Schultz (1990) Effects of the 65 mph speed limit on injury morbidity and mortality. *Accident Analysis & Prevention*, 22, 571-585.

Wang, B., S. Hallmark, P. Savolainen, and J. Dong (2018). Examining vehicle operating speeds on rural two-lane curves using naturalistic driving data, *Accident Analysis & Prevention*, Vol. 118, pp. 236-243.

Washington, S., Karlaftis, M. G., & Mannering, F. L. (2011). *Statistical and econometric methods for transportation data analysis*. Boca Raton, FL: CRC Press.

Weckesser, P.M., Gage, J.R., Hoffman, T., Horner, G.S., Kyte, G., Litwornia, A.J., Richie, S.M. and Streb, P.L., Implications of the Mandatory 55 MPH National Speed Limit. *Traffic Engineering*, Vo. 47, No .2, pp. 21-28, 1977.

Welford, A. T. (1980). *Choice reaction time: Basic concepts*. New York, NY: Academic Press.

West, L.B. and Dunn, J., *Accidents, Speed Deviation and Speed Limits*. Institute of Traffic Engineering, 1971.

White, S. & A. Nelson (1970) Some effects of measurement errors in estimating involvement rate as a function of deviation from mean traffic speed. *Journal of Safety Research*.

Wilmot, C. G. & M. Khanal (1999) Effect of speed limits on speed and safety: a review. *Transport Reviews*, 19(4), 315-329.

Wood, J., & Zhang, S. (2017). Evaluating Relationships Between Perception-Reaction Times, Emergency Deceleration Rates, and Crash Outcomes Using Naturalistic Driving Data (Rep. No. MPC 17 -338). Fargo: Mountain-Plains Consortium.

Young, K., & Regan, M. (2007). *Driver Distraction: A Review of the Literature*. Australasian College of Road Safety, 379-405. Retrieved from Google.

Zlatoper, T.J., *Determinants of Motor Vehicle Deaths in the United States: A Cross-Sectional Analysis*. *Accident Analysis & Prevention*, Vol. 23, No. 5, pp. 431-436, 1991.

Zwahlen, H. T. 1987. *Advisory speed signs and curve signs and their effect on driver eye scanning and driving performance*.