

2019 Pacific Northwest Highway-Rail Conference

NCUTCD / MUTCD Updates

April 23, 2019



Current Status of MUTCD

- Current MUTCD effective on January 2009
- Original plan was for update every 5-6 years
- NPA to be released under new Administration
- NPA is planned for summer 2019
- Review of comments and final rule will likely push MUTCD to 2020

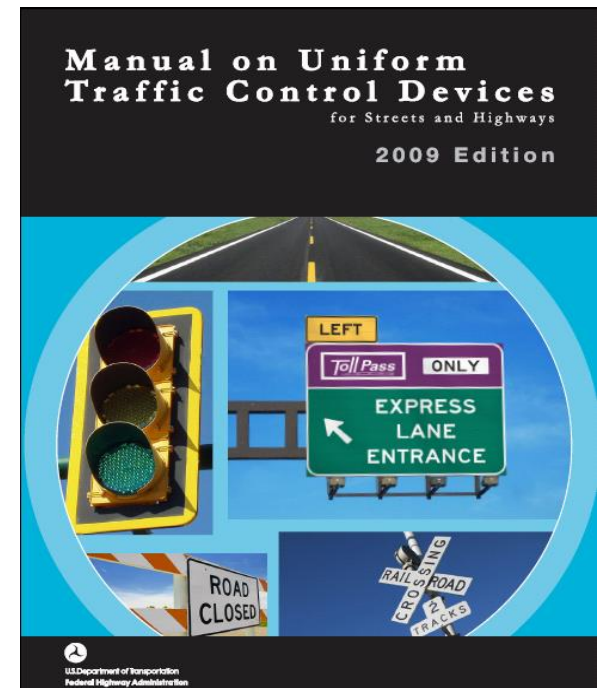

National Committee on Uniform Traffic Control Devices

- NCUTCD Formed in 1979
- Its purpose is to assist FHWA in development of standards, guidance and warrants for Traffic Control Devices
- 8 Technical Committees
- 23 Sponsoring Organizations
- Over 250 members including State DOT, State Regulatory Agencies, Transit, Cities, Counties, Technical Experts, Suppliers and Railroads



MUTCD Part 8

Railroad and Light Rail Transit Grade Crossings

- All Chapters in Part 8 will have modifications, some are substantial, one is new
- National Committee approved 15 sets of proposed changes
- 3 proposed changes currently pending
- Major changes to Diagnostic Teams and Procedures, Traffic Signal Preemption and Pedestrian Access / Sidewalks at Grade Crossings
- New Chapter on Busways

Proposed Changes to Definitions in Section 1A.13:

- Defines a Diagnostic Team
- Defines a Through Train
- Defines the Preemption Clearance Interval
- Defines a Queue Cutter Signal
- Defines a Sidewalk Grade Crossing
- Defines a Swing Gate
- Clarification to Minimum Track Clearance Distance, Clear Storage Distance and Pre-Signal

Proposed Changes to Chapter 8A

Specifies the Diagnostic Team Process and Members Standard:

- **Operational changes made to a traffic control system at a grade crossing requiring the use of engineering judgment or an engineering study shall be conducted or approved by a Diagnostic Team.**
- **The Diagnostic Team members shall reach a determination, documented as an engineering study, on proposed changes to a traffic control system at a grade crossing. The Diagnostic Team determination shall be made based on a consensus of the Diagnostic Team members.**

Proposed Changes to Chapter 8A

Specifies the Diagnostic Team Process and Members

Option:

- The Diagnostic Team determination may be based on site visits, meetings, conference calls, or a combination of some or all of these methods.
- When determined by the responsible public agency, the railroad company and/or transit agency, minor operational changes or general maintenance activities to the traffic control system at a grade crossing that do not have a negative impact on the overall operation of the traffic control system may be made without a review and determination by a Diagnostic Team.

Proposed Changes to Chapter 8A

Specifies LRT Rights-of-Way

LRT alignments can be grouped into one of the following three types:

- A. LRT exclusive alignment (“exclusive alignment”). This type of alignment does not have grade crossings and is not further addressed in Part 8.
- B. LRT semi-exclusive alignment (“semi-exclusive alignment”).
- C. LRT lane mixed-use alignment (“mixed-use alignment”).

Proposed Changes to Chapter 8A

Specifies LRT Rights-of-Way

LRT operations within semi-exclusive or mixed-use alignments may operate in one of two modes:

- LRT vehicles do not have priority over other road users.
- LRT vehicles have priority over other road users,

Proposed Changes to Chapter 8A

Medians at Grade Crossings

If the roadway at a grade crossing includes a two-way left-turn lane (see Section 3B.05), the two-way left-turn lane should be discontinued in the immediate vicinity of the grade crossing by installing median islands, by designating the lane for left turns in one direction only, or by installing yellow diagonal markings in the lane (see Figure 3B-5). If yellow diagonal markings are used, the use of channelizing devices (see Section 3I.01), such as supplemental tubular markers, should also be considered.

Proposed Changes to Chapter 8A

Medians at Grade Crossings

Where a raised median island is installed supplemental to an automatic gate to discourage road users from driving around a lowered gate, the Diagnostic Team should consider the length of the vehicle queues that typically form on the approach to the grade crossing when determining how far in advance of the grade crossing to extend the island.

(This is not for quiet zones, but grade crossings in general)

Proposed Changes to Chapter 8A

Provides guidance for Adjacent Grade Crossings

This can occur with parallel railroads or a railroad and a LRT facility

Guidance:

- *Where grade crossings are located within 200' of each other along the highway, the Diagnostic Team should consider the arrival of a second train when one grade crossing is occupied.*

Proposed Changes to Chapter 8A

Provides guidance for Adjacent Grade Crossings

Guidance:

- *Where the distance between tracks, measured along the highway between the inside rails, is 100 feet or less, the grade crossings should be treated as one individual grade crossing.*

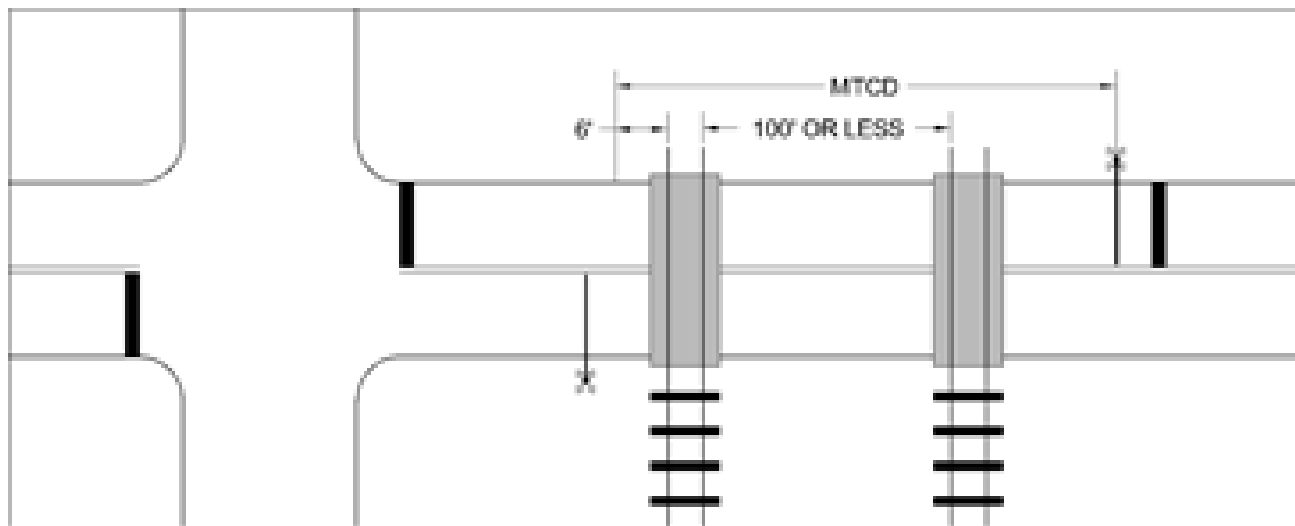

Proposed Changes to Chapter 8A

Provides guidance for Adjacent Grade Crossings

Guidance:

- *Where the distance between tracks, measured along the highway between the inside rails, exceeds 100 feet, the grade crossings should be treated as individual grade crossings and traffic control devices should be installed and coordinated between the grade crossings.*

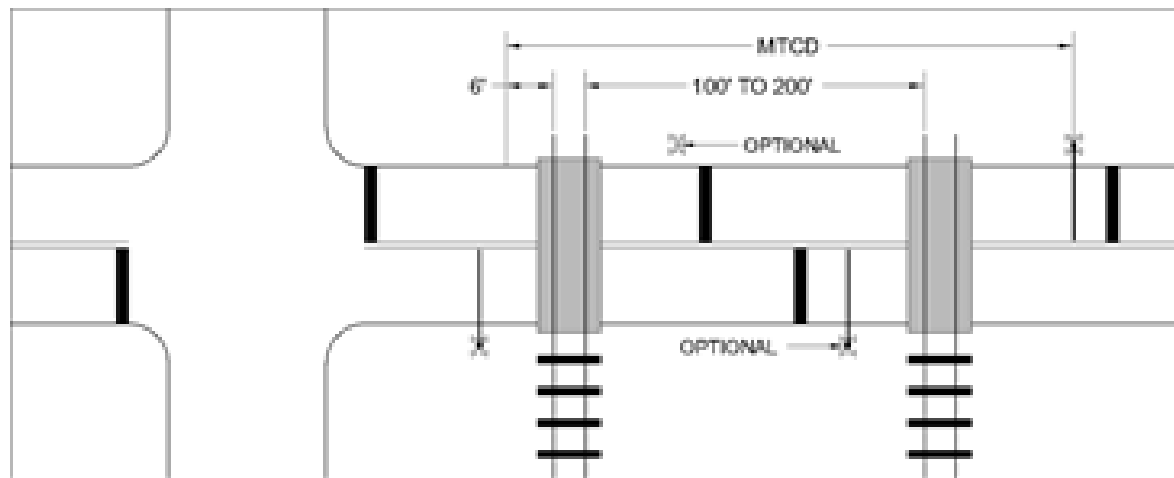

Proposed Changes to Chapter 8A

Provides guidance for Adjacent Grade Crossings

Guidance:

- *Where the distance between tracks, measured along the highway between the inside rails, exceeds 200 feet, the grade crossings should be treated as individual grade crossings and traffic control devices should be installed between the grade crossings.*

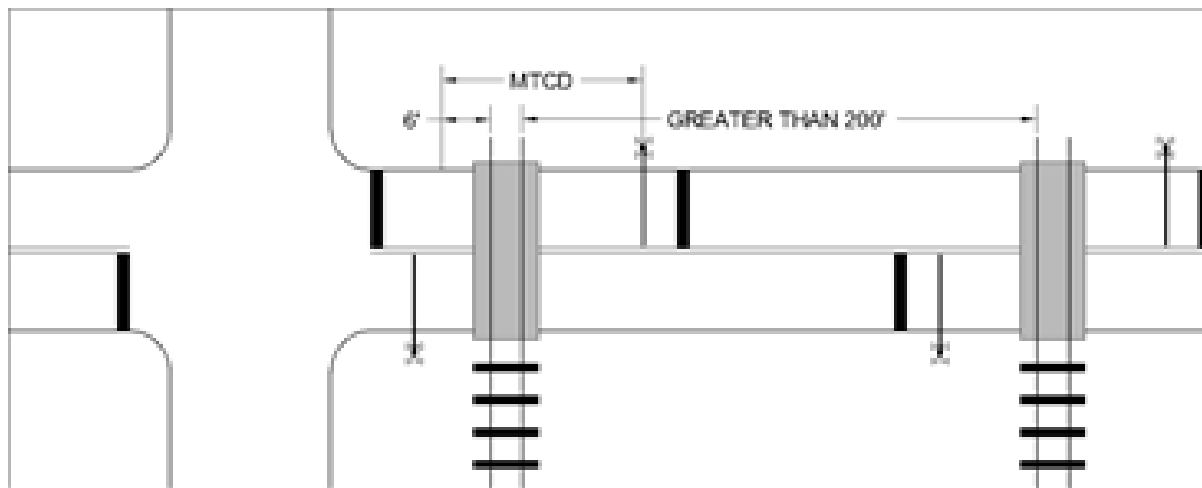

Proposed Changes to Chapter 8A

Provides guidance for Temporary Traffic Control near or impacting a Grade Crossing

Standard:

- **When a grade crossing exists either within or in the vicinity of a temporary traffic control zone, lane restrictions, flagging (see Chapter 6E), or other operations shall not be performed in a manner that would cause highway vehicles to stop on the railroad or LRT tracks, unless a flagger or uniformed law enforcement officer is provided at the grade crossing to minimize the possibility of highway vehicles stopping on the tracks, even if automatic warning devices are in place.**

Proposed Changes to Chapter 8B

- Multiple Track Sign standard for all multi-track Crossings
- Look Sign moved to Chapter on pathway crossings
- Prohibit use of Stop / Yield signs on the Crossbuck at crossings controlled by traffic signals

Proposed Changes to Chapter 8B

- Specify orientation of ENS signage

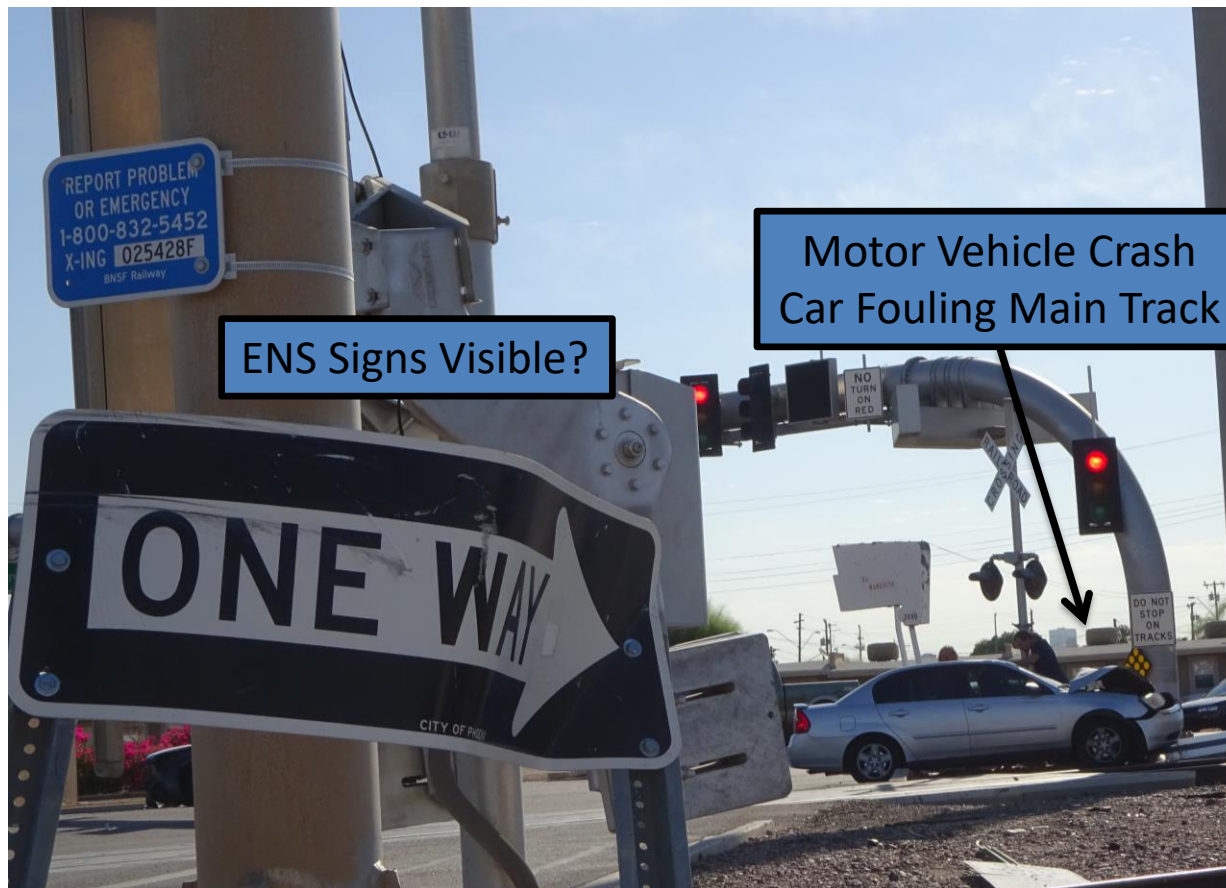

Proposed Changes to Chapter 8B

- Promote the use of Edge Lines and/or Delineators across the Grade Crossing



Proposed Changes to Chapter 8B

- Change Stop Line location to outer most crossing warning device (cantilever or gate)
- Limitations of Turn Arrow Pavement Markings at Grade Crossings (100' before to 20' beyond)



Proposed Changes to Chapter 8C

- One pair of lights for each approach lane should be provided
- Back lights should be provided for one-way streets / divided roads with sidewalks



Proposed Changes to Chapter 8C

- Specify that LRT speed criteria is the LRT maximum operating speed
- Modify minimum type of warning devices for specific LRT maximum operating speeds
- Eliminate the need for safety zone for grade crossings with exit gates – not necessary with dynamic operating mode for exit gates

Proposed Major Revisions on Preemption

- 3 year effort involving a Joint Task Force between Signals and RRLRT Technical Committees
- Recommends annual joint inspections
- Signal faces within 50' of a grade crossing shall display Red with an approaching train
- Prohibit Right Turn on Red if Pre-Signals are used without a right turn signal indication

Proposed Major Revisions on Preemption

- Circular Intersections (Roundabouts) within 200' of a Grade Crossing must have an Engineering Study conducted
- If traffic queues from the circular intersection impact the grade crossing, provisions should be made to clear highway traffic from the grade crossing prior to the arrival of rail traffic.
- Active train approach beacons must operate on fail-safe principles

Proposed Major Revisions on Preemption

Pedestrian Hybrid Beacons should be preempted within 200' of a grade crossing



Proposed Major Revisions on Preemption

- Restrictions on type of signal faces on Pre-Signals

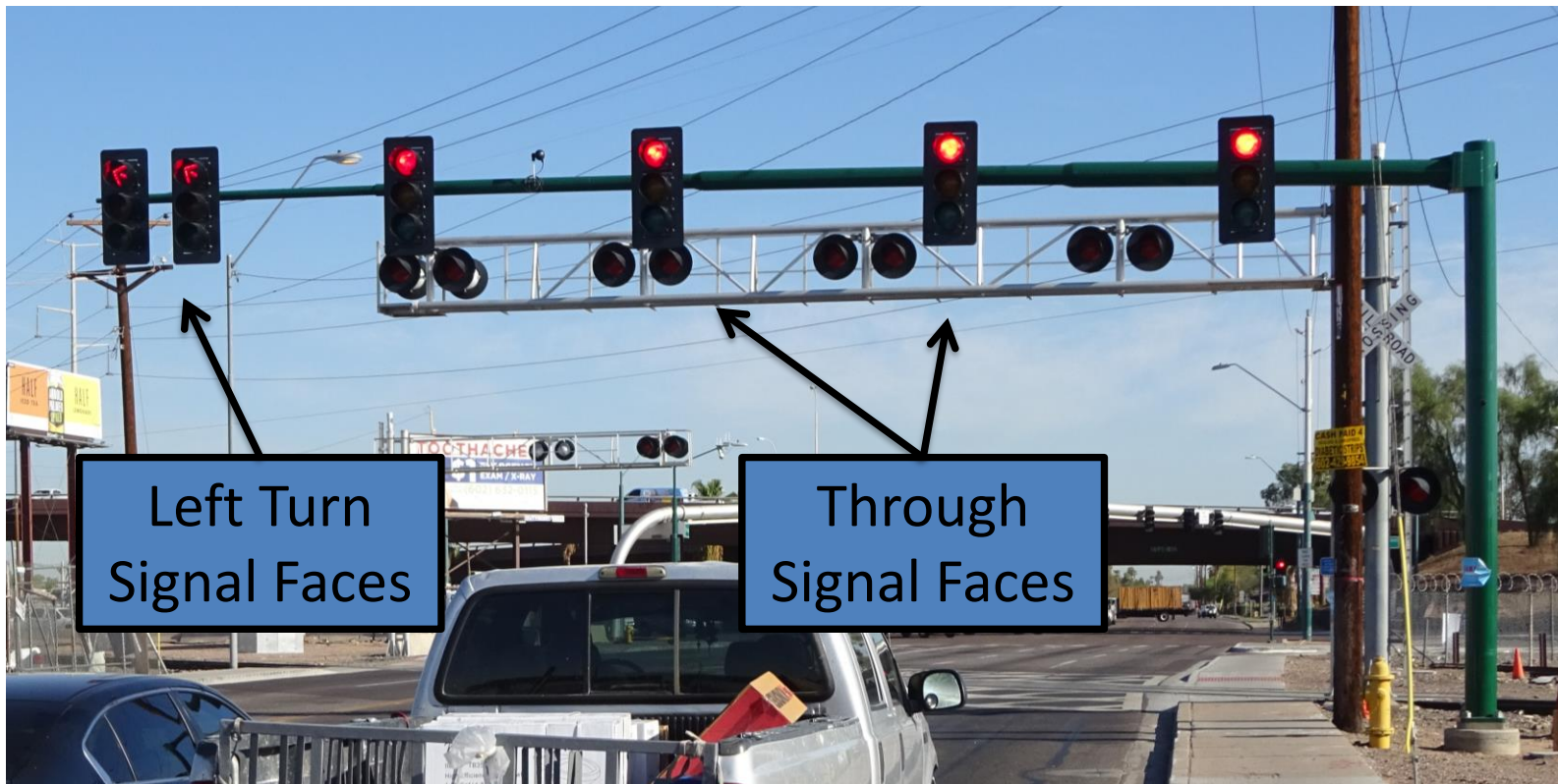

Proposed Changes to Chapter 8D

- Detectable Warning is required on approaches no less than 12' from near rail
- Look sign if used limited to Pathway & Sidewalk crossings and on separate post

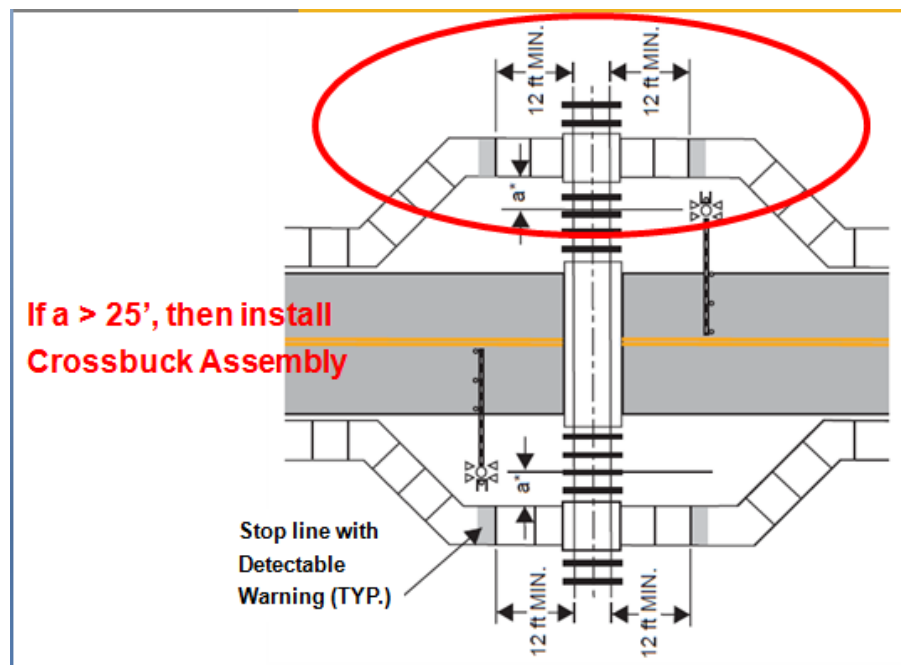

Proposed Changes to Chapter 8D

- If maximum train speed greater than 79 mph: Pedestrian Gates w/escape path required
- Section on the use of Swing Gates
- If automatic Pedestrian Gates used, fencing and an escape path should be provided

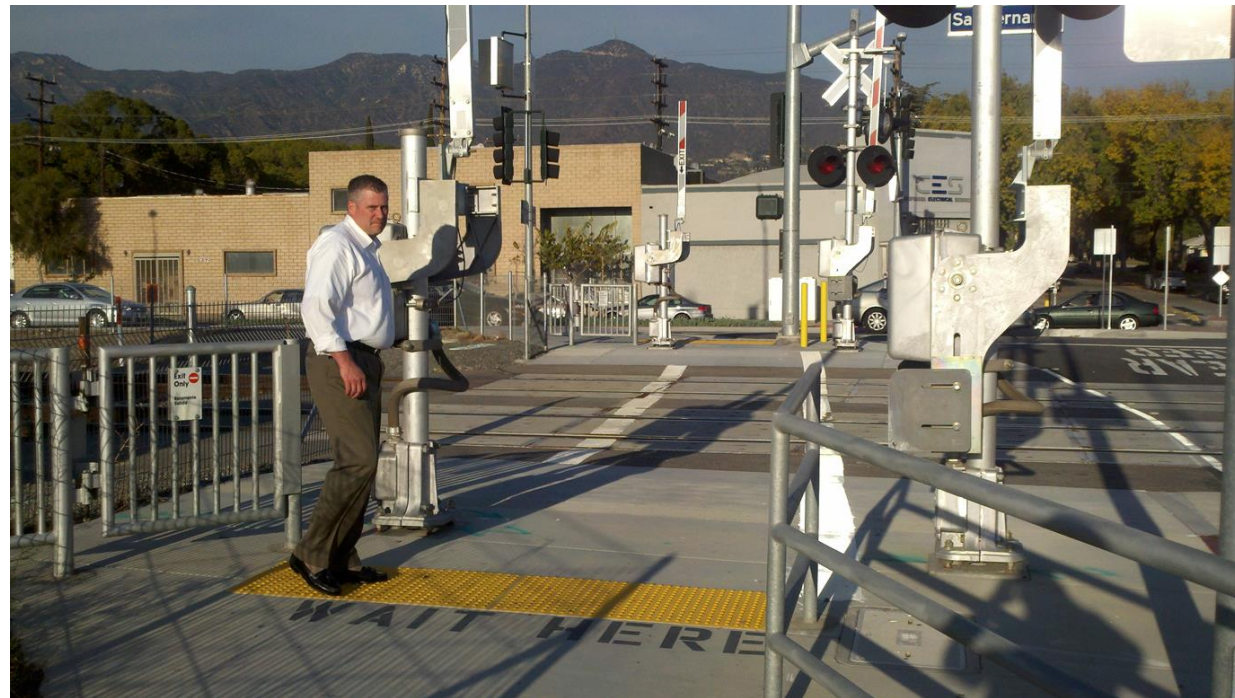

Proposed Changes to Chapter 8D

- Prohibit use of pedestrian signals at grade crossings



Proposed Changes to Chapter 8D

- If used, combination vehicle/pedestrian (scissor) gates must operate independently



Proposed New Chapter 8E Busways

- Provides definitions to support Busways
- Exclusive & Semi-Exclusive ROW
- Signalized like LRT
- Automatic gates meeting requirements set forth in Chapter 8C may be used to supplement traffic signals



Pending Recommended Changes to Part 8

- Crossbuck and “Tracks” Plaque (if present) mounted just above flashing light backgrounds
- Clearance of warning devices relative to track determined by railroad standards
- Revision to clarify definition of Right-of-Way Transfer Time

QUESTIONS





Saving lives one crossing at a time

Rick Campbell

rcampbell@ctcinc.com

Nicole Jackson

njackson@ctcinc.com