



# Introduction to Railroad Signaling and Grade Crossing Operations

October 18, 2018



## Call-in Information

Please use this call-in number:  
(866) 216-6835

## Purpose of Today's Webinar

- **Develop a Basic Understanding of Railroad Signaling** and its relationship to Active Warning Devices at Highway Grade Crossings, and to help answer the question of why some crossings cost more than others to install.
- **Discuss and share information** with State DOTs and Railroads.
- **Please Note:**  
This is an orientation document, not a design directive document.



### Kate Hulbert:

Good afternoon and welcome, I'm Kate Hulbert, the new FHWA SHRP2 sponsor.

Let's get started with this SHRP2 Webinar, an INTRODUCTION TO RAILROAD SIGNALING AND GRADE CROSSING OPERATIONS.

Our goal today is to present an orientation to railroad signaling that will increase your overall understanding of how the signal system functions.

This is an orientation presentation, and not design guidance. Many aspects of railroad signal design have been simplified or omitted to present an overview in place of design guidance.

A recent poll of Community of Interest members indicated their interest in learning about signal systems and their interaction with grade crossing projects with a desire to understand why some crossings cost more to install than others. We'll start with the basics of railroad signal systems to provide a background to more detailed discussions that will provide insight to these questions.

We want this webinar also to be interactive – so we want to hear from you, both your questions and your comments.

I will now turn it over to Pam Hutton, AASHTO's SHRP2 Implementation Manager and a Railroad-DOT Mitigation Strategies Product Lead, who will outline the agenda for you.

## Agenda

- Welcome
- Safety Moment
- SHRP2 Program and R16 Information
- Introduction to Railroad Signaling



**Pam Hutton:**

Welcome to you all and we are so appreciative that you have joined us today. There is a list of attendees on the left side of the screen and while I won't go name by name, we know you are here and we welcome your active participation today.

Today's webinar will last about 2 hours, 90 minutes of presentation and 30 minutes of Questions and Answers.

It is designed to encourage having as much interaction and input as possible during the Question and Answer session.

## Safety Moment

- Operation Lifesaver
  - There are No Small Trains
  - The ratio of the weight of a loaded 30 car freight train to a car is the same as a car to an empty soda can.
  - A 150 car freight train can take over 2 miles to stop.
  - Trains may move on any track at any time in any direction.

[www.OLI.org](http://www.OLI.org)



SHRP2 SOLUTIONS | 5

### Pam Hutton:

Our safety moment today is a reminder about safety at highway/rail grade crossings. The message comes from Operation Lifesaver.

Operation Lifesaver is a nonprofit public safety education and awareness organization dedicated to reducing collisions, fatalities and injuries at highway-rail crossings and trespassing on or near railroad tracks.

They remind us that;

- There are No Small Trains, the ratio of the weight of a loaded 30 car freight train to a car is the same as a car to an empty soda can.
- A 150 car freight train can take over 2 miles to stop.

Operation Life Saver asks us to remember that;

- Trains may move on any track at any time in any direction.

## SHRP2 Implementation: INNOVATE. IMPLEMENT. IMPROVE.

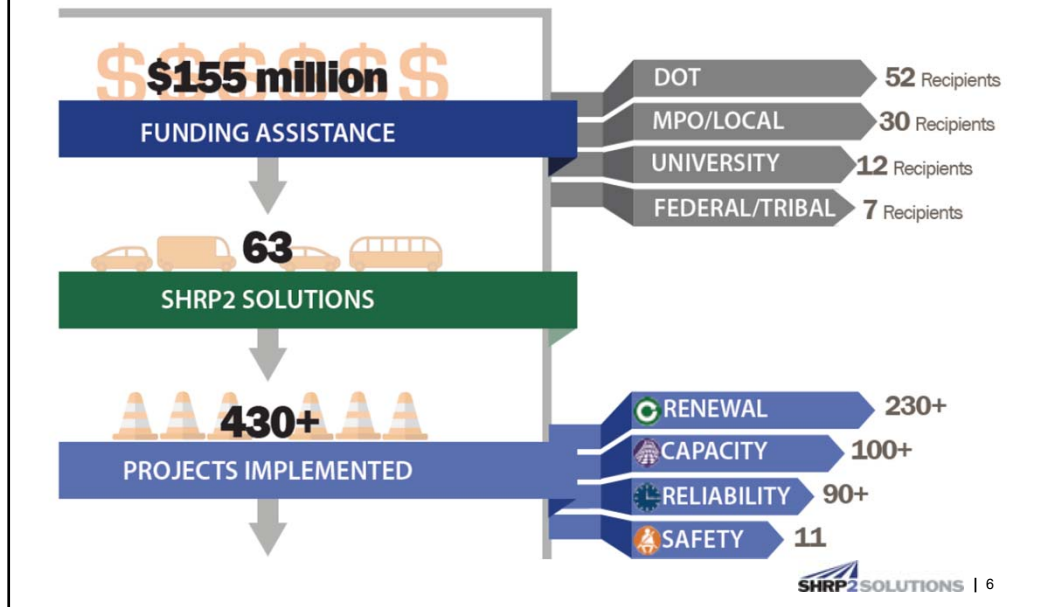

TBD

For those of you who are new to SHRP2, let me spend just a few minutes providing you some background and context.

- As you can see, we continue to provide funding for more than 430 projects now in implementation.
- More than \$155 millions in technical and financial assistance has been distributed to more than 100 entities including DOTs, MPOs, local agencies, universities and Federal and tribal agencies.
- For every \$1 invested by a DOT in SHRP2 Implementation, the average is a \$2 return on the investment.

# SHRP2 Implementation: INNOVATE. IMPLEMENT. IMPROVE.

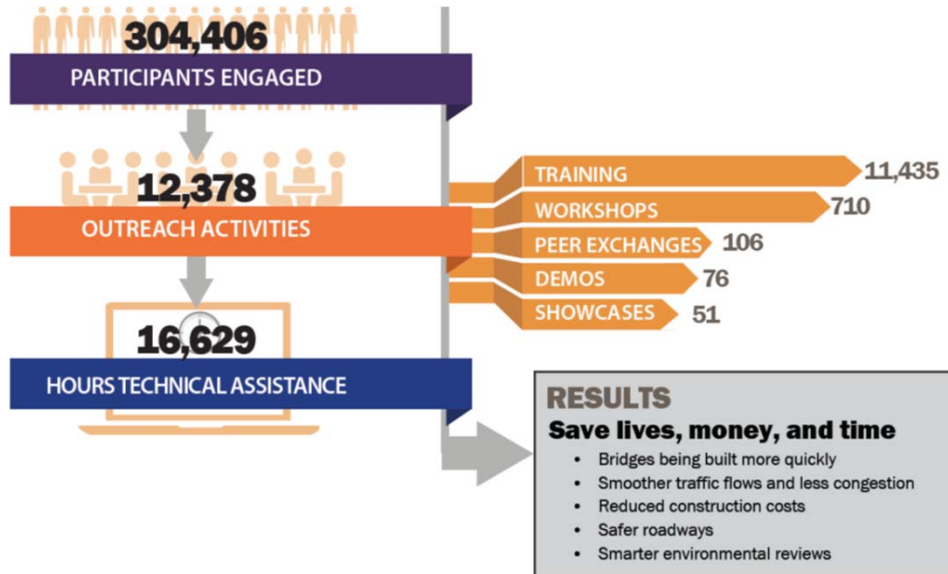

TBD

This infographic shows the number of individuals engaged with SHRP2 and the various outreach activities they participate in.

## Railroad-DOT Mitigation Strategies (R16)

### Challenge

- Railroad-DOT interaction requires a thorough review of the safety, engineering, and the operational impacts of a roadway project during construction – since it will have lasting effects on the railroad for decades thereafter. Rapid construction goals require a new approach that eases the project agreement process for both industries.



### Solution

- Recommended practices, model agreements, and training materials to help resolve potential conflicts.



SHRP2 SOLUTIONS | 8

### TBD

Now more specific to today's Peer Exchange, the *Railroad-DOT Mitigation Strategies* SHRP2 product, also known as R16, was initiated because of project delays due to the lack of collaboration between DOTs and railroads.

Freight movement is receiving more attention due to its impact on our economy. Railroads haul a significant portion of the freight moved in the country (38% of domestic freight ton-miles) and are key to the movement of global shipments from the ports of entry to the American heartland and back.

That being said, the solutions developed under R16 use a collaborative approach to address the challenges faced with expediting highway and rail projects in a time where railroads are upgrading and expanding their rail networks and DOTs are seeking ways to reduce the time it takes to complete highway construction projects.



## R16 Range of Activities

- Host Community of Interest providing forum for sharing of best practices and challenges
  - annual face to face meeting in Q1
  - quarterly meetings by webinar
- Host SHRP2, R16 Web Page
- Provide SME Technical Assistance
- Host Webinars, topics selected by COI
- Host annual Peer Exchange in Q3
- Produce Case Studies of most value to the COI
- Host state workshops to meet specific state DOT needs

**TBD**

Since the inception of the R16 product a few years ago, we use the following methods to share best practices in a very wide range of areas.

(Kate or Pam mentions highlights from the list)

## Innovation Library – R16 Webpage

- A library of agreements and other documents developed by state DOTs and rail agencies.
- State and Railroad Agreements, Manuals, and Processes (R16)
  - Organized by State/Railroad
  - Organized by Topic

[http://shrp2.transportation.org/Pages/R16\\_InnovationLibrary.aspx](http://shrp2.transportation.org/Pages/R16_InnovationLibrary.aspx)

### TBD

The R16 Innovation Library is a great resource, as it houses agreements already developed by state DOTs and railroads. You can find what you're looking for in two different ways— either by specific states, or by document topic.

That is the direct site for the Innovation Library, but you can also access it by searching at [SHRP2.transportation.org](http://SHRP2.transportation.org).

**AASHTO** **SHRP2 SOLUTIONS**  
TOOLS FOR THE ROAD AHEAD

**SHRP 2** **R16 Innovation Library - State**

AASHTO > Strategic Highway Research Program 2 > R16 Innovation Library - State

**Innovation Library - Agreements, Manuals, and Processes Organized by State and Railroad (R16)**

A library of agreements and other documents developed by state DOTs and rail agencies.  
To view these documents sorted by TOPIC, click here.

**Connecticut Department of Transportation**

- ConnDOT Amtrak Support Service Master Agreement

**Delaware Department of Transportation**

- Delaware DOT Railroad Coordination Workshop Slides

**Georgia Department of Transportation**

- Georgia DOT CSX Railroad Special Provisions
- Georgia DOT CSX Right of Entry Acquisition Agreement Form
- Georgia DOT CSX Special Provision CSX Higher Atlanta Division
- Georgia DOT Guidance on Right of Way Acquisition
- Georgia DOT Norfolk Southern Railroad Master Agreement
- Georgia DOT Norfolk Southern Right of Way Agreement Form
- Georgia DOT Norfolk Southern Special Provisions
- Georgia DOT Vertical Clearance of Bridges over Railroad Tracks
- Georgia DOT Railroad Plan Submittal Checklist

**Illinois Department of Transportation**

- Illinois DOT Flagger Agreement

**Need More Information?**  
Pamela Hutton  
SHRP2 Implementation Mgr  
phutton@aaashto.org  
303-263-1212

TBD

Here's just a view of the Innovation Library when searching by state—You can see that various states have documents up for reference. You can also search by topic, as I referenced in the previous slide.

## A Few Housekeeping Details

- **Tell us what you think.** We want to hear from all of you on the call during the Question and Answer portion of the webinar.
- **Do not use your computer's audio;** use the call-in number instead.
- **State your name and organization before speaking.**
- **Download the agenda and PDF of this presentation from the Files section.**



### **Pam Hutton:**

As we get started, I want to go over a few housekeeping details.

After the presentation, our goal is to engage you and your expertise in sharing information, best practices, challenges, and successes.

At the beginning, the phones are muted for the presentation. At the end of the presentation when we ask you for questions or comments, we will unmute the participants.

When raising a question or comment, please state your name and organization before speaking. You may also make a comment or raise a question at any time during the broadcast by typing it into the chat box. Our presenters will be monitoring the chat box will try and get to all comments during the session.

The agenda for today's webinar and a PDF of this presentation are available in the Handouts section. Additionally because the material is very technical, the speaker's notes will also be available.

# Railroad Signaling

- **Learning Objectives**
  - Block signal systems
  - Track circuits
  - Aspects and Indications
  - Railroad Signal Systems
  - Positive Train Control (PTC)
  - Grade Crossing Control Circuitry
  - Advanced Preemption

## Mike Loehr:

We have a lot of ground to cover today, so we won't be doing a deep dive into the theory, but will focus on how signals are implemented.

We'll cover

- Block signal systems
- Track circuits
- Aspects and Indications
- Railroad Signal Systems
- Positive Train Control (PTC)
- Grade Crossing Control Circuitry
- Advanced Pre-emption

Kenneth and I will try to avoid too much jargon, but signals does have its own vocabulary just like every other engineering discipline, and understanding the vocabulary is half the battle understanding railroad signal systems.

## Why do we need signals?

**Mike Loehr:**

So, why do we need signals?

We will answer this question, and others in this presentation.

# Signals

- **Why do we need Signals?**

- Safety
  - Prevent collisions
- Capacity
  - More trains on the same amount of track
- Increase & Enforce Speed
  - Regulations
  - Operations



Photo © Michael Loehr 2018

SHRP2 SOLUTIONS | 15

## Mike Loehr:

The primary reason for having signals is safety. Signals and adherence to the rules prevent collisions.

Another key reason for signals is that they increase capacity on a rail line by allowing more trains to operate over the track.

Lastly the use of railroad signals can increase the speeds of trains, the engineer doesn't need to be able to operate in a line of sight like when you drive a car, the signals tell the engineer that the track ahead is clear. Advanced signaling systems can also enforce speeds to increase safety.

## Signals – Block Signal Systems

- **Why do we need signals? – Safety & Capacity**

- 1 Train
  - No risk of collision
  - Limited capacity

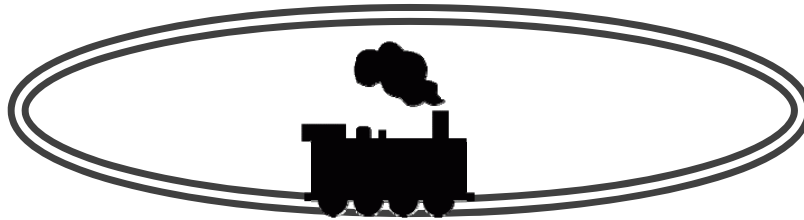

Figure © Michael Loehr 2014

SHRP2 SOLUTIONS | 16

### Mike Loehr:

This slide depicts a simple railroad with no signals and a single train. Since there is only one train, there is no risk of it colliding with itself.

The problem is that there is only one train. That limits the amount of revenue that it can produce.



## Signals – Block Signal Systems

- **Why do we need signals? – Safety & Capacity**

- 2 Trains

- Increased capacity
- Risk of collision

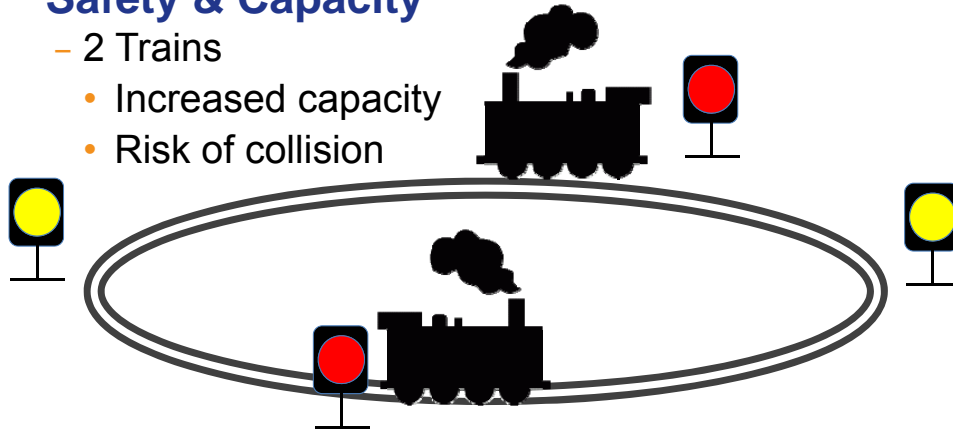

Figure © Michael Loehr 2014

### Mike Loehr:

To increase capacity (and revenue) a second train is added. Now there is a risk of collisions, so a simple signal system is introduced.

Just like a traffic light, the red signal means stop. The red signals keep the trains from colliding. But train operations are slow because the engineer must operate the train ready to stop at the red signals. And with no more information, the operator never knows where the other train is.

To increase the speed, more signals are added, the yellow signals in the slide. Yellow signals do not mean speed up like most drivers think they mean at highway intersections.

Yellow on the railroad means that the next signal is red, but that there is no train between the signals. With the other train is beyond the red signal and not between the yellow and red signals, the yellow gives the engineer the ability to move forward, but adds a requirement to operate at a speed lower than the maximum speed, and to be ready to stop at the red signal.

## Signals - Block Signal Systems

- **Why do we need signals? – Speed**
  - More Blocks

Figure © Michael Loehr 2014

SHRP2 SOLUTIONS | 18

**Mike Loehr:**

In the previous case, the engineer is either stopping, or getting ready to stop. This slows the trains down.

To increase the train speeds, more signals are added. Now the engineer gets a green light that allows the train to move as fast as allowed to the next signal. The next signal is green in the example so the engineer keeps moving as fast as allowed.

The engineer gets to the yellow signal, and now knows that the next signal will be red, and slows the train to a speed where the train can be stopped at the red signal.

The yellow signal is always placed so that the train can be stopped at the red signal. There is no dilemma zone where the engineer has to decide to stop or proceed like you can find in traffic signaling, the yellow railroad signal gives adequate warning to allow the train to stop at the red railroad signal.

This is one the fundamentals of railroad signaling.

# Signals – Track Circuits

- **General Arrangement**

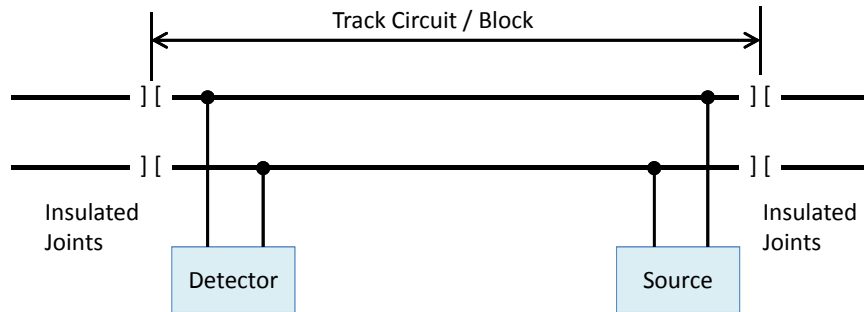

- The source sends a continuous signal that is detected by the detector. If signal is interrupted due to shunting, broken wire, broken rail, defective source or detector, then Block is considered occupied.

Figure © Michael Loehr 2018

SHRP2 SOLUTIONS | 19

## Mike Loehr:

Under railroad operating rules a Block is a specified section of track. When signals are used, the blocks become the track segments between the signal locations, often the limits of a single track circuit. Two or more track circuits may be necessary if the signal blocks are very long, but for ease of discussion, we'll assume that a block and a track circuit are synonymous.

A track circuit or block is the next fundamental building block of a signal system. A track circuit consists of three major components, some sort of a source, the rails in the block, and a detector of some sort. The source sends a continuous signal that is received by the detector. If the signal is interrupted, the block and track circuit are considered occupied.

The continuous signal sent by the source may be interrupted by a broken track wire, a broken rail, a shunt on the track, a defective source, or a defective detector. A train will shunt the circuit. Shunting is the railroad term for the shorting between the rails by the steel wheels and axle on the trains.

Filling a track with ballast ahead of surfacing can also shunt the circuit, as can a steel surveyor's tape. The right of entry the railroad gives to a DOT or your contractors probably

has some language in it specifying that only fiberglass tapes are to be used. Shunting by a steel tape is the reason for this language.

# Signals – Track Circuits

- **Specific Types of Track Circuits**

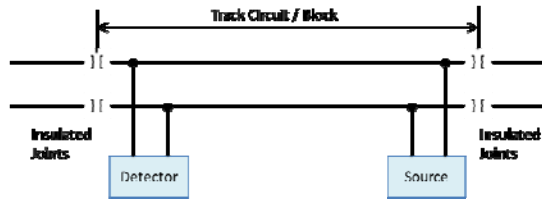

Circuit Type	Detector	Source
Type C, AC/DC	AC Rejection Relay	Rectifier / AC Voltage
DC Track Circuit	DC Track Relay	Track Battery
AC Track Circuit	AC Centrifugal Relay	AC Signal Power
Coded Track	DC Ballistic Relays	DC Code Generator
Audio Frequency*	Tuned Receiver	Tone Generator

\* Audio Frequency circuits may use shunts in place of, or in conjunction with Insulated Joints. Frequencies are selected for compatibility between adjacent blocks.

Figure © Michael Loehr 2018



**Mike Loehr:**

Several options exist for signal sources and detectors. Let's talk about some real examples.

- A Type C, or AC/DC type of circuit uses an AC voltage and a rectifier that converts the AC to DC as its source. This is a common circuit on older crossings on branch lines or industrial tracks. The detector is a relay that can tell if a train shunts (short across the rail) by the signal going from DC to AC to indicate a train.
- A DC track circuit, the most common type, uses a battery connected to the rails at one end, and a DC track relay connected at the other end. If there is voltage at the relay, there is no train shunting or occupying the track circuit/block.
- An AC track circuit replaces the battery in the DC circuit with an AC voltage at a specific frequency, and uses a centrifugal relay to detect the AC voltage. No voltage matching the frequency of the AC relay means a train is shunting the track circuit, even if other voltages are present.
- In a coded track circuit, additional information is provided in the track circuit about adjacent signals, eliminating the pole line and all the wires next to the track. The codes

are DC pulses on the track that are decoded by ballistic relay to determine the information. No code (or 0 code) means the track is occupied.

- A modern track circuits can use audio frequencies from a tone generator as the source. The detector is a tuned receiver that is set to the same frequency as the tone generator. If the tone is interrupted or the track is shunted, the block is occupied.

## Track Circuits

- **Fail Safe**

- A “Fail Safe” system is when track circuits are arranged in such a way so that if any part of the circuit fails, then the block is assumed to be occupied.
- Railroad signal engineers will use the “fail safe” term, but prefer to use the more technical term of a fail-to-a-known condition to describe their circuitry.

**Mike Loehr:**

Fail Safe

The track circuits are arranged in such a way that if any part of the circuit fails, then the block is considered to be occupied. This creates a ‘fail safe’ system.

Railroad signal engineers will use the ‘fail safe’ term, but do prefer the more technical term of a ‘fail-to-a-known condition’ to describe their circuitry.

This is the other fundamental basis of signaling.

Let’s move on to how tracks circuits are assembled into a signaling system that controls train operations.

# Signals – Block Signal Systems

- **General Arrangement**

**Typical 3-Aspect System – Class 4 Track (Freight 60 MPH max.)**

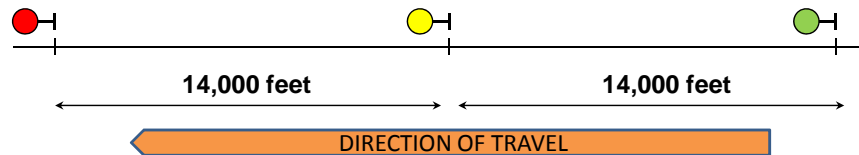

**Typical 5-Aspect System – Class 5 Track (Mixed 70 / 90 MPH)**

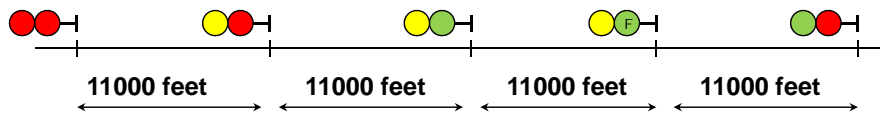

Figures from CSX signal upgrade presentation

SHRP2 SOLUTIONS | 22

**Mike Loehr:**

- We've talked about track circuits as individual entities. When you combine track circuits; however, you create a signal system. The track circuits are used to control the signals that, in turn, control the trains. To provide for safety, the blocks are long enough for a train to stop before the STOP signal, what the railroads call Safe Braking Distance. Safe Braking Distance varies by train type, speed, and route profile. Trains going downhill take longer to stop.
- In our earlier discussion about signal systems, we limited ourselves to a RED / YELLOW / GREEN, or 3-Aspect signal system for simplicity.
- A 5-Aspect System adds two more elements to the 3 aspects. In the 3-Aspect System, the train is either stopped, getting ready to stop, or running full speed. In a 5-Aspect System, the trains can be stepped down between full speed to two intermediate speeds before getting ready to stop, increasing the overall speed.
- In the 3-Aspect System shown above, the train goes from 60 mph to Stop in the 14,000 feet between the YELLOW and RED signals. In the 5-Aspect System, the train goes from 90 mph to 60 mph in 11,000 feet, then 60 mph to 40 mph in the next 11,000 feet, and finally from 40 mph to Stop in the last 11,000 feet.



# Rules of the Railroad

- The *Employee Timetable* provides information on speeds, track layout, crossings, operations, rules in effect, and locations.
- The *Operating Rules Book* describes how trains and the signal system interact and how the trains are to be operated.

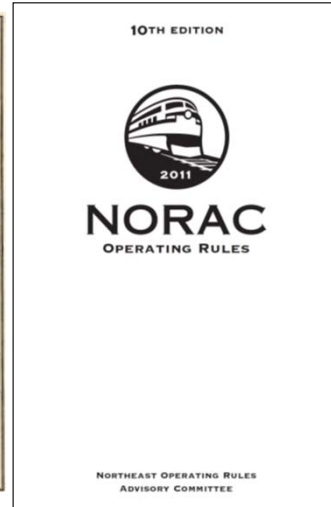

## Mike Loehr:

Signals by themselves do not allow the railroad to operate.

The Employee Timetable provides information on speeds, operations, rules in effect, and locations.

The Operating Rules Book describes how trains and the signal system interact and how the trains are to be operated.

## Signals – Aspects and Indications

- **Name** – What it is Called
- **Aspects** – How it Looks
- **Indications** – What it Means

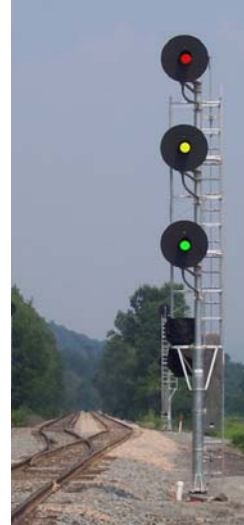

Photo © Michael Loehr 2014

SHRP2 SOLUTIONS | 24

### Mike Loehr:

I've used some Jargon in the last section, but when you speak to railroad signal engineers this is the language you can expect to be used.

There are three basic terms for the signals;

Name – What it is Called

Aspect – How it looks

Indication – What the signal means under the operating rules.

## Signals - Aspects and Indications

- Vary from Line to Line, Railroad to Railroad



Images left, left middle and far right from Wikipedia, Right middle © Michael Loehr 2014

SHRP2 SOLUTIONS | 25

### Mike Loehr:

The railroad signaling environment is complex. Train engineers and conductors are required to learn all of the aspects, names, and indications on every section of railroad they operate over.

In Pennsylvania on NS or on Amtrak's North East Corridor you might see the Position Light Aspects like the photo on the left,

If you are in Pennsylvania on CSX you might see the aspect in the third picture.

If you are a SEPTA engineer running from a former Pennsylvania Railroad line like the Media/Elwyn Line onto a former Reading Railroad line like the Chestnut Hill East Line by going through 30<sup>th</sup> Street Station, you might see all of the different types of aspects.

The railroads are working hard to standardize their systems, but it will take decades more time.

## Signals – Signal Systems

- **Dispatcher Control System (DCS)**
  - Oldest and simplest system currently in use
  - No Signals / Track Circuits are required (Dark Territory)
  - Dispatcher authorizes movement
    - Issues Train Orders or
    - Movement Forms
  - Controls movement between Block Stations or railroad locations
    - Stations
    - Mile Posts

### **Kenneth Shields;**

We are going to talk about the different railroad signal systems, starting with the simplest and oldest and work our way up to the modern Positive Train Control Systems. Each of these systems represent an increasing level of operational performance. In the event of a failure in a higher level railroad signal system these systems can be used to maintain the operations of the railroad, albeit at lower operational ]performance levels.

The first signaling system we will discuss is really not a signaling system at all, but is a railroad operating practice.

- Dispatcher Control System or Dark Territory is a method for moving trains when no signal system is present. I've included this because if signals fail to their fail-safe position, the train operations degrade through several levels with the lowest being Dispatcher Control System.
- Dispatcher Control System is also used on some lines where signaling is not practical due to the remoteness of the locations or the low level of traffic.
- Current implementations of a Dispatcher Control System are setup so that the trains have specific movement authorities between block stations, with typically one train at a time in a block. The rules for this system do allow for trains to follow each other, or to

enter at the center of a block after the first train passes and run in opposite directions. The Dispatcher issues train orders that describe the train's movement authority.

## Signals – Block Signal Systems

- **Automatic Block Signal (ABS)**
  - Block Signals required (Signalized Territory)
  - Dispatcher controls route
    - Towers or Block Stations
  - Train Movement controlled by Automatic signals
    - Dispatcher can issue Train Orders or Movement Forms

### **Kenneth Shields;**

- The next level of a signal system is an Automatic Block Signal or ABS . Automatic Block Signal systems and track circuits were developed in the 1880's. Trains receive their authority to operate from the indications of the signal system. Towers or Block Stations are used like Dispatcher Control Systems to control trains entering or leaving sections of the railroad, but trains operate between Towers based on the signal indications. Automatic Block Signal systems are still in use on many lines today.
- In this scenario, the Tower operators set the routes for the trains to the next Tower locally under the direction of the Dispatcher. Originally the switches were thrown by large levers on an interlocking machine in the tower, and later by electric control panels.
- The term “interlocking” comes from the mechanical interlocking machines. The machines enabled switches to operate only in certain sequences and combinations, and only if the track circuits and signals were in specific conditions. The conditions were interconnected or ‘inter-locked’ mechanically and electrically to prevent unapproved combinations or sequences to be performed, similar to the interlock in a car that won't allow the engine to start unless the transmission is in park or neutral.
- Under the Automatic Block Signal rules, the Dispatcher can issue train orders to further control the train's movements.
- Train Orders are transmitted over the radio to the train crews or are written in special forms and delivered to the moving train by the Tower operator as the train passes the

tower.

## Signals – Block Signal Systems

- **Safety Enforcement**

- Automatic Train Control (ATC)
- Automatic Train Stop (ATS)
- Other Non-Positive Train Control systems
  - All use signal system and onboard systems to prevent undesired actions such as:
    - Over Speed (Authorized and Civil)
    - Passing a railroad Stop signal

### **Kenneth Shields;**

Automatic Train Control (ATC) and Automatic Train Stop (ATS) are older fixed-block signal systems that were early attempts to improve safety by enforcing train operating speeds and preventing trains from going past railroad STOP signals. These systems are common on public mass transit systems and are used in some railroad areas.

There are many variants in the implementation of both systems, but they are often implemented with Cab Signals (signal repeaters in the operating cab of the train) that use coded track circuits that transmit signal information in the rails to the train.

Neither Automatic Train Control nor Automatic Train Stop reach the threshold of being Positive Train Control systems, but are often an additional layer on top of Automatic Block Signal or Central Traffic Control signal systems to provide an additional level of fall-back to the Positive Train Control system.



## Signals – Advanced Signal Systems

- **Central Traffic Control (CTC)**
  - Block Signals required (Signalized Territory)
    - May not always have wayside signals
  - Dispatcher controls route & signals at Control Points (CP)
    - No Towers or Block Stations
  - Train Movement controlled by Dispatcher and Automatic signals
    - Dispatcher can issue Train Orders or Movement Forms

### **Kenneth Shields;**

Centralized Traffic Control, Central Traffic Control, or what some railroads call Traffic Control Systems (TCS), have been operational since the 1930's. It is the next level of signal system above an Automatic Block Signal system. Central Traffic Control has slowly replaced Automatic Block Signal signal systems on mainline railroads. Under Central Traffic Control, a Dispatcher can directly control 'Control Points' or 'CP' from a central location.

The signal indications at the Control Points control the movement of trains without tower operators.

Like Automatic Block Signal and Dispatcher Control Systems, the Dispatcher can issue train orders to further control the train operations.

## Signals – Signal Systems

- **Communications-Based Train Control (CBTC)**
  - Also called Moving Block
  - No Wayside Signals required
  - Dispatcher controls route & signals at Control Points (CP)
    - No Towers or Block Stations
    - Dispatcher can issue Train Orders or Movement Forms
  - Train movement controlled by onboard systems
  - Includes Positive Train Control systems
  - Trains communicate location, speed, and size, and other trains compute how to avoid each other on the same track.

### **Kenneth Shields;**

As the numbers of trains increase, fixed-block systems like Automatic Block Signal and Central Traffic Control reach their maximum capacity below the theoretical capacity of what the tracks can handle. The capacity constraint is because the fixed blocks must be set to control the lowest performance train in terms of braking distance, so a line that carries 2-mile long coal trains that take over a mile to stop must have blocks arranged to provide the 'Safe Braking Distance' (SBD) for that train, while the 10-car commuter train may be able to stop in ½ that distance.

Communications-Based Train Control solves this by not having fixed blocks. The trains maintain separation from the train ahead based on the known location of the end of the train ahead and the Safe Braking Distance of the following train. This is similar to what we do every day on the highway. We keep a safe distance between our car and the car ahead. We can see the end of the car ahead and know our car can stop as fast as the car ahead.

We'll discuss Positive Train Control later in the presentation.

## Signals – Speeds

- **Speeds**

- Maximum Authorized Speed (MAS)
  - Varies by type of train
- Signal Speeds
  - Not all signals specify maximum speed
    - A **Clear** signal allows Maximum Authorized Speed, not a maximum speed
    - An **Approach** signal allows medium speed (30 MPH)
  - Signal speeds vary by routing, and distance to signals ahead
  - Signal speeds vary by track occupancy ahead

### Kenneth Shields;

When we first answered the question: ‘Why do we need Signals’, one of the reasons was to increase speeds and capacities of the railroad.

- Speeds on the railroad are handled differently from highway speeds. Railroads speak in terms of Maximum Authorized Speeds (MAS, pronounced em ay es). The Maximum Authorized Speed on a section of track may vary by the type of train we are talking about. Passenger trains and Intermodal trains are typically special classifications of trains with higher Maximum Authorized Speed than other trains.
- Passenger and Intermodal train speeds are higher because the equipment is designed for the higher speeds, and because even at their higher speeds, their Safe Braking Distance is less than regular freight trains, so the fixed block signal systems can provide safe operations.
- Like a green traffic signal, the signal system provides for only Maximum Authorized Speed, not a specific speed. A **Green** traffic signal in a 25-mph zone allows only 25 mph, while the same green traffic signal in a 45-mph zone allows 45 mph. A **Clear** railroad signal only allows the Maximum Authorized Speed for a specific type of train on that track segment.
- It is important to note that not all signal systems provide speed information directly, we’ll talk about that on the next slide.

## Signals – Block Signal Systems

- **Signal Systems**

- **Speed Signaling**

- Signals set the speed limits for the train operator to control the train accordingly.

- **Route Signaling**

- Signals tell the train where it is going and the operator knows the speeds for that route and controls the train accordingly.

### **Kenneth Shields;**

Speed Signaling is a type of railroad signaling system that provides the train with speed information. Maximum Authorized Speed is still by train and route type; however, a yellow railroad signal would set a Maximum Authorized Speed of 40 mph. The signal can set different speeds depending on the route selected.

A Route going straight through a switch would give a Clear signal allowing Maximum Authorized Speed for the train, but a Route diverging through the same switch towards a siding, for instance, could give a Limited Clear signal, allowing only Limited Speed (60 mph) through the switch if the switch size allowed that speed.

Under a Route signaling system, the signals convey route information to the train, and the engineer must control the train based on the route and Employee Time Table (ETT).

Under the same scenario as above, a Route going straight through a switch would give a Clear signal to the train, indicating to the engineer that the train is not diverging. If the Route was diverging through the switch, the signal would display a Diverging Clear, telling the engineer that the train must be operated at the diverging speed set in the Employee Time Table for that route.

## Signals – Speeds

- **Speeds**

- **Civil Speeds**

- Signals may not enforce civil restrictions. Positive Train Control and Automatic Train Control systems will.
    - Speeds set by engineering conditions such as curvature, bridge impact, super-elevations.
    - Often called curve restrictions
    - Listed in the Employee Time Table and in Train Orders

### **Kenneth Shields;**

The Civil Speed Restriction can be thought of similar to warning speeds on a highway with one significant difference. The overall road segment may be 55 mph, but a curve may be posted with a yellow and black sign just for a specific curve, indicating that the driver should consider slowing down. Civil Speed restrictions on the railroad are mandatory Maximum Authorized Speed for a given location. more like a black and white speed limit sign on the highway.

The Civil Speed Restriction could be in place because of a bridge with a low impact rating, or a steep curve without full superelevation. In the Employee Timetable a Route will have an overall Maximum Authorized Speed, but may have multiple Civil Speed Restrictions listed within that route.

Automatic Train Control Systems (Automatic Train Control) may enforce a Civil Restriction, but not all do. All Positive Train Control implementations will enforce Civil Speed Restrictions.

## Signals – Positive Train Control

- **Positive Train Control (PTC)**

- Required after a head-on collision – Metrolink and UPRR trains, Chatsworth, CA, September 12, 2008.

- Fatalities – 25
- Injuries – 135
- Damage - \$7.5 millions

### **Kenneth Shields;**

The National Transportation Safety Board (NTSB) had Positive Train Control (PTC) on its list of desirable technologies for over a decade due to on going accidents that this technology could have prevented.

On September 12, 2008, a Metrolink Commuter train passed a STOP signal and ran head-on into a Union Pacific freight train. 25 persons, including the engineer, died and 135 persons were injured. This accident proved to be the last straw in a succession of accidents that resulted in Congress mandating the railroad to implement Positive Train Control.

## Signals – Positive Train Control

- **Positive Train Control (PTC)**
  - Similar to Automatic Train Control/Automatic Train Stop
  - However, Automatic Train Control/Automatic Train Stop may not be positive control
    - May not implement temporary speed restrictions or work limits
  - May overlay existing Automatic Train Control, Central Traffic Control, Automatic Block Signal, and Dispatcher Control System.

### **Kenneth Shields;**

Congress's mandate for Positive Train Control required a system to prevent accidents. The mandated system would be similar to Automatic Train Control / Automatic Train Stop systems already in place, but would require additional protections to address other types of accidents.

Congress did not mandate a completely new system, they merely required that whatever system is implemented provided the protections required.

The railroads were concerned about reliability of the new technology and most have opted for a layered Positive Train Control system that could fail downward into a series of more restrictive operating requirements from Positive Train Control to Automatic Train Control to Automatic Block signals, and finally to Dispatcher Control System.

## Signals – Positive Train Control

- **Positive Train Control (PTC)**
  - **Enforce Speeds**
    - Signal (Operations)
    - Civil (Permanent)
    - Bulletin Order (Temporary) Speeds
  - **Enforce Limits of Authority**
    - Train has permission from A to B and not beyond
  - **Protect Railroad Worker Work Zone Limits**

### **Kenneth Shields;**

On October 16, 2008, Congress mandated the installation of Positive Train Control. Positive Train Control required, among other things, that will:

- Enforce signal operations; enforce temporary and permanent speed restrictions; enforce limits of authority; and enforce railroad worker work zone limits.

Because of how the railroads in the US operate, the railroads have required a level of interoperability across the systems since trains and locomotives may operate on tracks owned or operated by multiple railroads as they travel from their origin to their destination.

The railroads are working hard to meet a milestone date in December to have specific portions of the PTC system installed to allow them to go into continued development and testing. Amount of focus at the railroads is reminiscent of the focus the DOTs had when the new traffic laws went into place for Right on Red and raising the national speed limit. One major difference is that the railroads are developing a new technology at the same time they are deploying the system.



## Signals – Positive Train Control

- **Basic Communications-Based Train Control/  
Positive Train Control Concept of Operations**

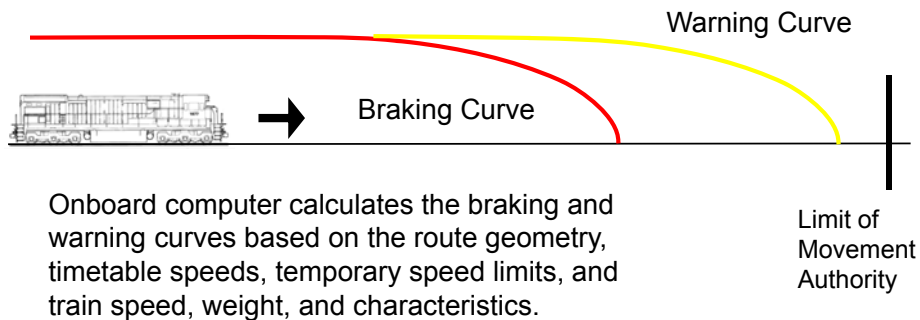

Figure © Michael Loehr 2014

SHRP2 SOLUTIONS | 37

### **Kenneth Shields;**

The basic concept of PTC is that each train is equipped with onboard computers and positioning systems. The systems have data about the train consist (the make up of a train - number of cars, loads vs. empties, locomotives, etc.), the route (grades, curves, speeds, miles posts, locations), and the Limit of Movement Authority.

The onboard system calculates a warning curve and a braking curve that extend out in front of the train based on the Safe Braking Distance plus warning time. When the warning curve reaches the Limit of Movement Authority, the system indicates to the train engineer to acknowledge the warning, and to take actions required to control the train. The system then monitors the operation of the train until the Safe Braking Curve reaches the Limit of Movement Authority when the system takes control of the train and makes a brake application to prevent the train from moving beyond the Limit of Movement Authority.

# Signals – Positive Train Control

## • Positive Train Control Train Operations Implementation

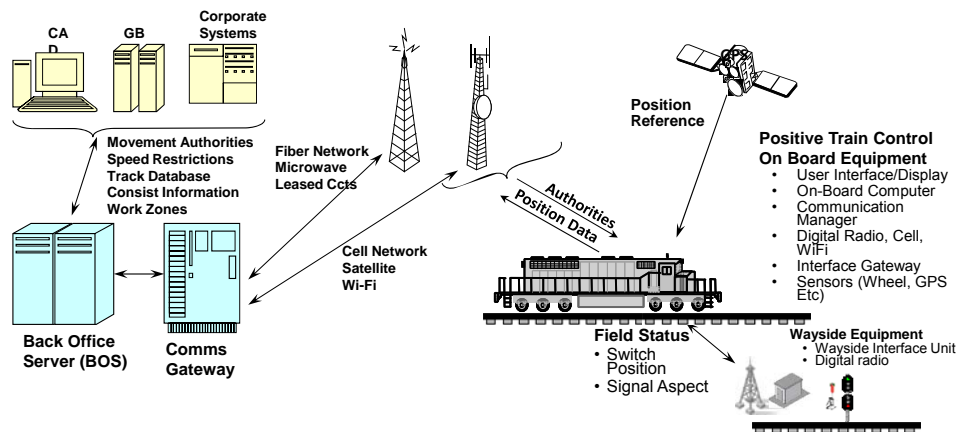

Figure from CN Railroad Positive Train Control Briefing adapted by Michael Loehr

### Kenneth Shields;

Positive Train Control is a complex system that connects each train into a network of data. When the Positive Train Control onboard system is initialized, data about the route is loaded, the Train Consist information is loaded, and any temporary speed restrictions are loaded.

As the train proceeds along the route, the onboard system communicates with wayside systems to determine their state and their health. If a switch is healthy and aligned properly, the train is allowed to continue, if the switch is not properly aligned or is unhealthy (some error condition) then the train is stopped before reaching that location. Temporary speed restrictions, Limits of Movement Authority, and location of Railroad Work Zones are constantly updated by redundant systems communicating between the train and the Wayside Interface Units (WIU) and the back office servers.

# Signals – Positive Train Control

- Positive Train Control Railroad Work Zone Implementation

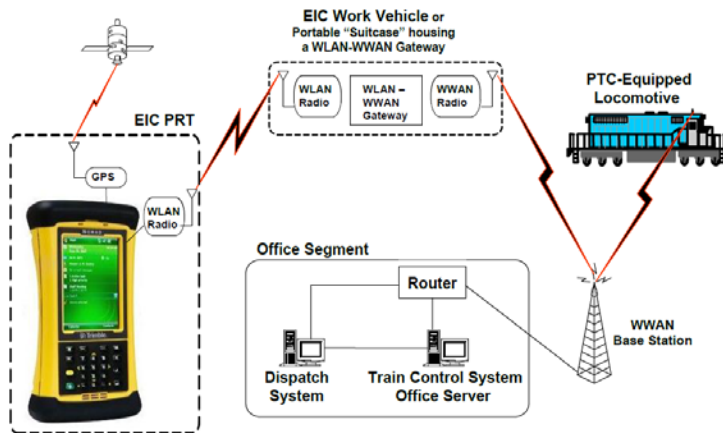

Figure from Federal Railroad Administration

## Kenneth Shields;

Two areas that separate Positive Train Control from Automatic Train Control/Automatic Train Stop and similar systems are the requirement that temporary speed restrictions (including Zero speeds) and the Railroad Work Zones be constantly updated. Each work zone has an Employee In Charge (EIC) in control of the work zone .

A track crew working at a location may have track and time permission on the track that temporarily modifies the train's Limit of Movement Authority until the track crew clears the track.

Similarly a track inspector may identify a condition that requires a temporary speed restriction to protect it.

In both of these cases, a field unit is used to request the track and time, and to place temporary speed restrictions directly into the Positive Train Control System. The data is updated on the trains, providing real time protection and control. Some of these systems are still in development and Positive Train Control allows manual entry of these items by a Dispatcher based on radio or from telephone calls from the field.

## Railroad Signal Systems

- Railroad Signal Systems are at least as complex and likely more complex than ITS systems deployed on the highways.
- Grade Crossing Warning Devices are installed into the existing railroad signal system and must be both technologically and operationally compatible with the existing railroad signals system.
- The newest grade crossing technology must operate with existing systems that may be up to a century old, or that may include functionally obsolete components no longer in production.

### **Kenneth Shields;**

Railroad Signal Systems are at least as complex and likely more complex than the ITS systems deployed on the highways.

Grade Crossing Warning Devices are installed into the existing railroad signal system and must be both technologically and operationally compatible with the existing railroad signals system.

The newest grade crossing technology must operate with existing systems that may be a century old, or that may include functionally obsolete components no longer in production.

# Signals – Grade Crossings

- **Guidance**

- AREMA Signal Manual
- ITE Recommended Practice
- TRB NCHRP Synthesis 271
- MUTCD
- DOT Standards

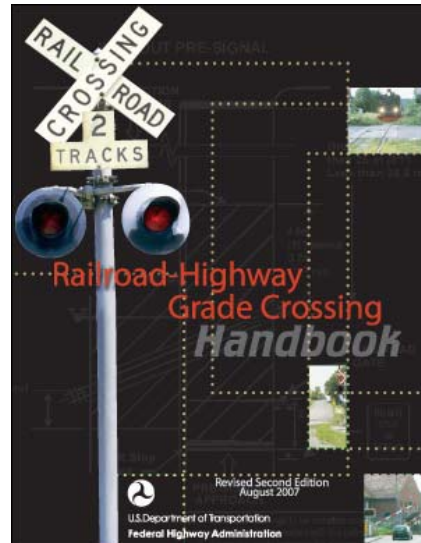

SHRP2 SOLUTIONS | 41

## Mike Loehr:

We are not going to go into the details of how Active Warning Devices are configured from a civil engineering perspective; that information is readily available from the sources on this slide.

What we will be talking about next is how the railroad signal systems operate the Active Warning Devices at the crossings, and how the civil engineering at crossings may affect the signal system.

# Signals – Grade Crossings

- **Basic Circuitry Implementation – Issues**

- **Loss of Shunt**

- 'Rusty Rail'
- Contaminated Rail
- Light Vehicles / Short Trains

- **Mitigation**

- Stop and Protect Rules
- Advanced Circuitry (rail chargers)
- Rail Modifications (Stainless Steel Strips, Roughening)
- Shunting Devices on Rail Vehicles
- Brushing rail to remove contamination

## Mike Loehr:

When Active Warning Devices are added to an existing or new crossing, the minimum expectation is that the warning devices function reliably and consistently.

The key to reliable operations is that the signal system reliability detects the approach of a train. On light density lines or lines where short/light trains are operated, the ability of the signal system to detect the train relies on the train shunting (shorting) the track circuit.

Shunting can be compromised by the generic term 'Rusty Rail'. Rusty Rail includes more than just rust and can include contaminated rail or the general ability of light vehicles or short trains to create an adequate shunt. Contamination can include sand on the rail used to stop a train at an adjacent station, or salt air corrosion and deposition on railheads on lines near the ocean.

Some of the proven mitigations to poor shunting include advanced circuitry and shunting devices on the rail vehicles.

## Signals – Grade Crossings

- **Functions of the Track Circuits**

- Approach Circuit

- Activates the crossing warning devices upon approach of a train
- May also activate pre-emption and advanced preemption traffic signal controller phases

- Island Circuit

- Hold the gates down until the train vacates the crossing

- Electronics in the crossing signal case interpret the circuits to provide either Constant Warning Time (Constant Warning Time) or a Fixed Start for the crossing.



### **Mike Loehr:**

There are three basic circuits required at a conventional crossing, two Approach Circuits, and an Island Circuit.

The Approach Circuits activate the crossing warning devices upon approach of a train from either direction, and may also activate pre-emption and advanced pre-emption traffic signal timer.

The Island Circuit holds the gates down until the train vacates the crossing.

Depending on the electronics in the crossing signal case, the track circuits can provide either Constant Warning Time or “Fixed Start” for the crossing.

# Signals – Grade Crossings

- **Basic Circuitry Implementation – Fixed Start**

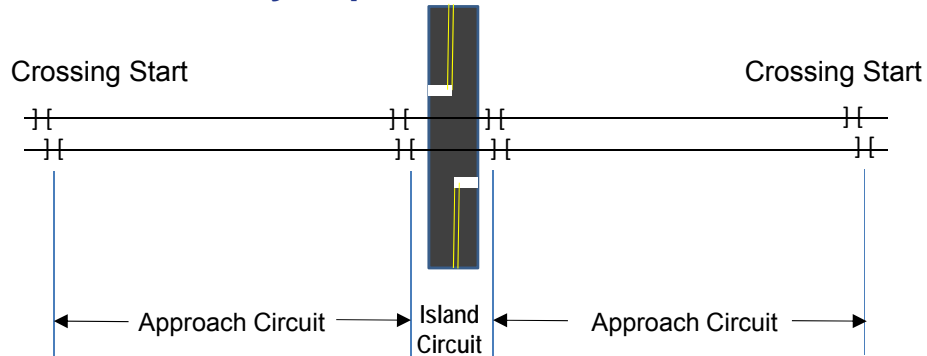

$$L_{\min.} = (\text{Acquisition Time}_{\max.} + \text{Warning Time}_{\min.}) \times \text{Speed}_{\max.}$$

$$1,686' = (3 \text{ sec.} + 20 \text{ sec.}) \times (50 \text{ mph} \times 88 \text{ fps} / 60 \text{ mph})$$

Figure © Michael Loehr 2014

SHRP2 SOLUTIONS | 44

## Mike Loehr:

In a fixed start crossing, the length of the Approach Circuits determines the Warning Time (WT) provided. Because the start is fixed, the warning time provided is variable and is a function of the train speed.

All of the track circuits have a delay from when the shunt is first placed on the track circuit until it is detected. This Equipment Response Time (ERT) or Acquisition Time is generally taken as 3 seconds.

The Minimum Warning Time (MWT) at a Crossing is set so that the flashers are activated not less than 20 seconds before the train enters the crossing.

The minimum length of the Approach Circuits can be calculated from the formula presented on the slide.

The warning time is variable at a crossing with a fixed start because of train speed. For example, a 30 mph train operates on a crossing where the approach is set for 50 mph. The train arrives later than the 20 seconds Minimum Warning Time that would be observed with 50 mph train.



# Signals – Grade Crossings

- **Basic Circuitry Implementation – Grade Crossing Predictors / Constant Warning Time**

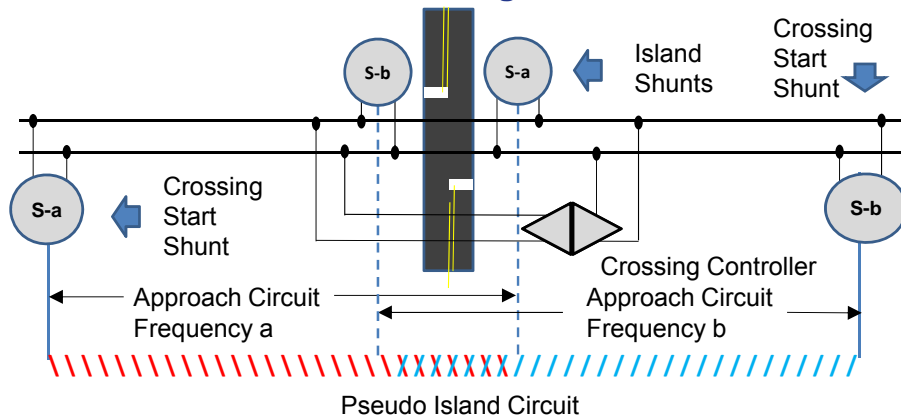

Figure © Michael Loehr 2014

## Mike Loehr:

Long crossing wait times can lead to undesirable (dangerous and illegal) driver behaviors. To solve this problem on lines where trains operate at different speeds, or where trains shift cars at plants near the crossings, Constant Warning Time controllers were developed.

The Constant Warning Time controllers use Audio Frequency track circuits and can measure the changes in the electrical characteristics of the circuit to determine the train's speed and to calculate an arrival time. The crossing is then activated only when needed to provide the Minimum Warning Time.

The original Constant Warning Time Controllers initially relied on three track circuits and 8 insulated joints. However, the insulated joints were not always needed and the Constant Warning Time controller was designed so that two overlapping Audio Frequency track circuits could be arranged to mimic three conventional track circuits.

Audio Frequency shunts are installed at the calculated approach circuit lengths and at the island circuit locations. The left hand frequency and the right hand frequency both go through and overlap in the island.

## Grade Crossing Audio Frequency Shunt

- **Narrow Band** (one target frequency)
- **Wide Band** (multiple frequencies)
- **Buried in the ballast, wires connect to rails**



Figure © Siemens

### Mike Loehr:

The Audio Frequency track shunts only shunt their design frequency, allowing other compatible frequencies to pass. Think of it like a cross over in your stereo speaker or surround sound system. The wire carries all of the frequencies, but the low frequencies are directed to the woofer or sub-woofer speakers while the high frequencies are sent to the tweeters.

Some railroads are going back to installing insulated joints with Downstream Adjacent Crossing (DAX) units and secondary audio track circuits since other signal circuits in the rails make Insulated Joints with the Audio Frequency shunts more reliable.

## Grade Crossing Controller

- **Microprocessor Based Controller**
- **Single or Multiple Tracks**
- **Programmable timings**



Figure © GE – HXP-3

SHRP2 SOLUTIONS | 47

### **Mike Loehr:**

The Constant Warning Time controller is a computer with interface devices that act as the source and detector in the track circuits. Additional electronics measure the change in the electrical characteristics of the track circuit to predict when the train will be at the crossing.

The shunts are placed on the approaches and the Minimum Warning Time and other parameters are programmed on the keypad.

The Constant Warning Time controller is similar in some ways to a highway traffic signal controller.

Different manufacturers have used different characteristics of the circuit to detect the changes.

These technologies may not allow for proper function if the new crossing overlaps with an existing crossing with different technology.

# Crossing Timing Calculations

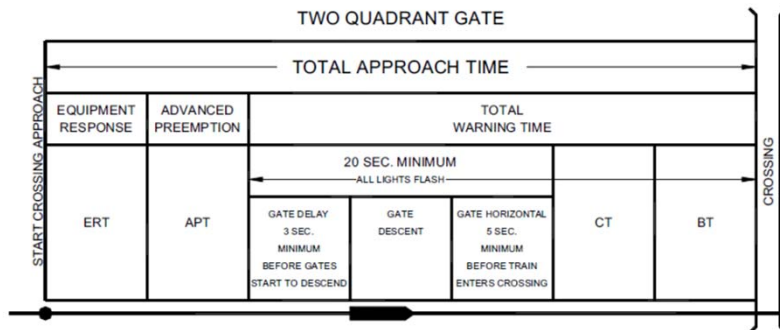

$$\begin{aligned} \text{Total Approach Time (TAT)} &= \text{ERT} + \text{APT} + \text{CT} + \text{BT} + \text{MWT} \\ &= 3 + \text{APT} + \text{CT} + \text{BT} + 20 \end{aligned}$$

CT = Clearance Time beyond that provided by MWT

The acronyms match the standard nomenclature in the AREMA table.

Figure © AREMA

SHRP2 SOLUTIONS | 48

## Mike Loehr:

The Minimum Warning Time is just that, the minimum. Additional Clearance Time (CT) and Buffer Time (BT) may be required by the railroad or regulatory agency standards.

Buffer time may be a systemwide standard, or may be added at specific crossings to account for frequent sequential activations where a second train is on the crossing start just after the first train clears the island circuit. This allows the gates to rise and then be lowered again. The addition of Buffer Time lengthens the Approach circuit so that the second train will be on the approach before the first train leaves the island, thereby holding the gates down. This is sometimes handled by **second train logic** in the controller.

The need for Additional Clearance Time is becoming more common as additional tracks for new services are added to existing crossings. The MWT includes the time it takes to clear two tracks at 13' track centers. Larger track centers, more tracks, or grades on the crossing approaches are all reasons that Clearance Time is added to Minimum Warning Time.

Advanced Preemption Time may be required when the grade crossing is interconnected with an adjacent traffic signal. The time needed for the traffic signal pre-emption phasing is added to the standard crossing approach times to allow traffic signal changes, creating

the Total Approach Time.

## Preemption and Advanced Preemption

- The practices for preemption and advanced preemption are evolving.
- The next edition of the AREMA manual is expected to have new timing and other considerations for preemption, including a revised maximum warning time limit.
- The MUTCD will also have new criteria for when to consider preemption.
- As grade crossings and traffic have developed and grown, the total warning times have increased. This has resulted in new issues with long gate down times and driver behaviors.
- Limitations of current controller technology make an upper limit on the Total Warning Time desirable.

 SHRP2 SOLUTIONS | 49

### Mike Loehr:

The practices for preemption and advanced preemption are evolving.

The next edition of the AREMA manual is expected to have new timing and other considerations for preemption, including a revised maximum warning time limit.

The new version of the MUTCD will also have new criteria for when to consider preemption related to the distance between the intersection and the crossing.

As grade crossings and traffic have developed and grown, the total warning times have increased. This has resulted in new issues with long gate down times and driver behaviors.

Limitations on current controller technology make an upper limit on the Total Warning Time desirable.

## Signals – Advanced Preemption

- Advanced Preemption is the practice of Interconnecting highway and grade crossing signals to assure traffic can clear for crossings in close proximity to an intersection.
  - Recommended by the NTSB after the Fox River Grove Collision between train and stopped school bus in 1995.
    - Fatalities – 7
    - Inadequate room for bus to be clear of tracks at Stop Bar.
    - Highway widening and traffic signal adjustments contributed to the crash.
    - Interconnection was not tested.
  - FRA issued a safety advisory for review of highway intersections in close proximity to railroad crossings.
- The MUTCD requires a review for the possible queueing of traffic across the tracks and handling such queueing as needed.

### Mike Loehr:

The Fox River Grove accident happened in 1995. A school bus was stopped at a newly relocated stop bar that was moved closer to the tracks by a roadway widening project. The preemption interconnect was made, but did not provide adequate change time to stop the conflicting traffic and allow the bus to move away from the crossing. Seven fatalities resulted from the crash.

A safety advisory was issued by the FRA for review of crossings in close proximity to railroad crossings, and a new requirement was included in the MUTCD to review for the possible queueing of traffic across the tracks and handling such queueing as needed.

# Signals – Advanced Preemption

- **Advanced Preemption Implementation**

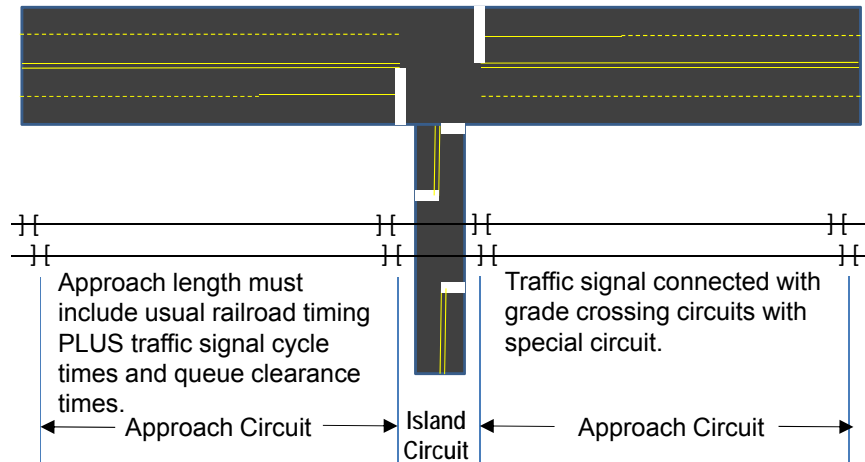

Figure © Michael Loehr 2014

SHRP2 SOLUTIONS | 51

## Mike Loehr:

The signal and control circuitry at a crossing with Advanced Preemption is the same as at other crossings with two major differences.

The first difference is that the timing to empty the queues from the crossing may lengthen the Total Approach Time (TAT). Traffic engineering analysis is required to determine how much time is needed to clear the queues from the track based on the traffic signal phasing and highway design criteria.

The second difference is the presence of a supervised interconnect circuit at preempted crossings.



# Supervised Railroad Interconnect

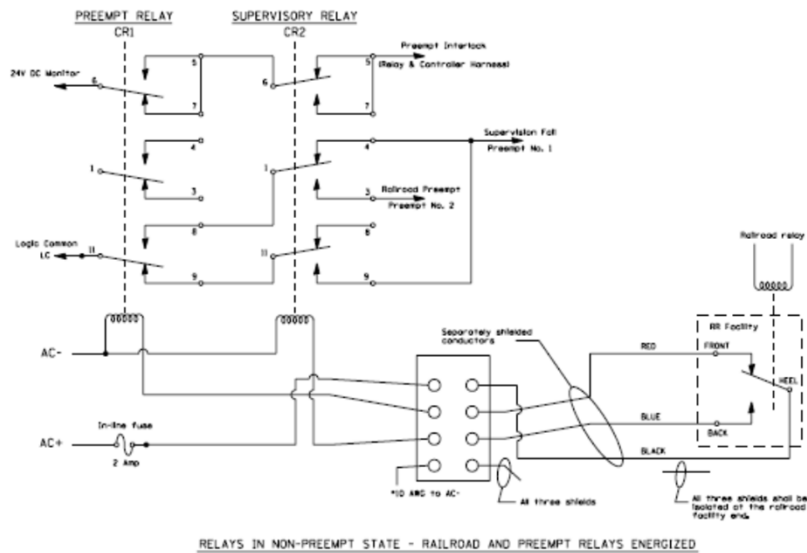

**Mike Loehr:**

Many old interconnect circuits are not supervised, meaning that a broken wire or a bad connection does not cause the traffic signal to enter preemption timing. The traffic signal controller does not receive the signal and just runs its normal phasing cycles.

A Supervised Railroad Interconnect circuit is developed using the railroad fail-safe design philosophy. This means that any failure places the traffic signal into the preemption cycle or raises an alert through the conflict monitor in the traffic signal controller and sets the railroad controller to Unhealthy.

Aside from the technical changes, the regulations require joint inspections, and configuration management by both the road owner and the railroad.

## Signals – Advanced Preemption

- **Timing**

- FHWA/ITE has developed the methodology that has become a best practice.
- The Texas Transportation Institute's (TTI) worksheet is a common tool but the methodology can produce longer warning times than needed. Therefore, it is not universally accepted, but the considerations and concepts hold for even complex cases.
- DOTs, railroads, and agencies have developed their own procedures based on the best practices and their unique operating environments.

**Mike Loehr:**

Advanced Preemption Timing is a complete subject in itself. For this introduction, we are only going to reference the material and look at the example of the type of considerations and their effect on crossings.

On the next two slides we have very simplified animations of simultaneous and advanced preemption.

## Factors Affecting Grade Crossings

- Crossings operate within the overall railroad system, and cannot be thought of as just a single discrete location.
- Many factors can affect implementing active warning devices at a crossing.
- Diagnostics teams need to consider all of these factors to generate a comprehensive scope of work for the crossing project.



Photo source Wikipedia

SHRP2 SOLUTIONS | 54

### Mike Loehr:

Crossings operate within the overall railroad system, and cannot be thought of as just a single discrete location.

Many factors can affect implementing active warning devices at a crossing.

DOT/Railroad Diagnostics teams need to consider all of these factors to generate a comprehensive scope of work for the crossing project. Many DOTs have standardized forms that help organize the data collection process.

## Why Could Additional Signal Work Be Required to Install a Crossing?

- The R16 Community of Interest raised this question.
- Many possible reasons require this, given the actual site conditions, including:
  - Whether a signal system is in use on a track;
  - Whether obsolete technology prevents changes;
  - The type of adjacent equipment or locations; or
  - Incompatibility of existing equipment and Constant Warning Time technology.

### **Mike Loehr:**

We are now going to answer some of the questions from the last Community of Interest meeting.

The first question we wanted to answer is “Why Could Additional Signal Work Be Required to Install a Crossing?”

Or stated a little differently, “Why do different crossings have different costs?”

I’ve listed some of the overarching issues on the following slides, let’s discuss them one at a time...

## Grade Crossing Case – Shelf Relays



Photo © Michael Loehr 2011

### Mike Loehr:

Many crossings are still using equipment whose design dates back to the early 1900's. Some of the individual parts may be original to the initial installation. Relays are tested at intervals between two and five years, depending on the relay's purpose. The test is for operational parameters, and relays can have lives of over 100 years. Monthly inspections of the grade crossing operations are employed to verify the proper operation of all parts of the active crossing system.

Upgrading the grade crossing devices at a crossing with shelf relays will typically require replacement of all of the relays and the case with modern equipment. This adds to the cost of the crossing.

## Grade Crossing Case – Microprocessor

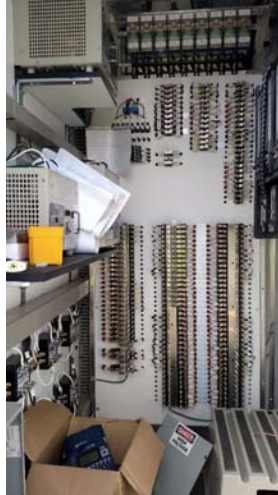

Photo © Michael Loehr 2018

SHRP2SOLUTIONS | 57

### **Mike Loehr:**

This grade crossing case is a new location using a microprocessor controller that provides Constant Warning Time. This allows the local municipality, for example, to request a Quiet Zone designation on crossings in this area to eliminate the use of Train Horns.

The modern version of the shelf relays, called plug-in relays, are visible in the top right portion of the photo. The microprocessor Constant Warning Time unit is the black box on the right side of the photo.

## Factors Affecting Grade Crossings

- **Signals adjacent to the crossing considerations**
  - Train stopping location
  - Lower train speeds due to Acceleration / Deceleration
- **Items that may affect the cost of the crossing installation**
  - Additional circuitry
  - Constant Warning Time Equipment in place of fixed starts



Photo © Mike Loehr 2017

SHRP2 SOLUTIONS | 58

### Mike Loehr:

Signals adjacent to the crossing can have multiple effects on the crossing cost due to impacts that include:

- Additional Circuitry;
- Considerations of Train stopping location; and,
- Use of Constant Warning Time equipment due to lower train speeds due to Acceleration / Deceleration in response to the signal indications.

Items that may affect the cost of the crossing installation include Additional Circuitry, and Constant Warning Time Equipment in place of fixed starts.

## Factors Affecting Grade Crossings

- Passenger stations adjacent to the crossing
  - Effects of station dwell time on gate downtime
  - Lower train speed due to Acceleration / Deceleration
  - Pedestrian gates and controls
- Items that may affect the cost of the crossing installation
  - Pedestrian gates and controls



Photo © Mike Loehr 2017

SHRP2 SOLUTIONS | 59

### Mike Loehr:

Passenger stations adjacent to the crossing have effects from station dwell time on gate down time, lower train speeds due to Acceleration / Deceleration and the need for Constant Warning Time and crossing time out considerations, and possible pedestrian gates and controls.



## Factors Affecting Grade Crossings

- Interlockings and switches adjacent to the crossing
  - Frequent activations of the crossing if the railroad switches an industrial siding near by.
  - Lower train speed due to Acceleration / Deceleration
  - Train stopping locations
  - Additional circuitry
- Items that may affect the cost the crossing installation
  - Constant Warning Time Equipment in place of fixed starts.
  - Additional circuitry



Photo © Mike Loehr 2017

SHRP2 SOLUTIONS | 60

### Mike Loehr:

Interlockings and switches adjacent to the crossing have impacts, including lower train speeds due to Acceleration / Deceleration, train stopping locations, and the need for additional circuitry.

In this example, trains on either track beyond the switch need to activate the crossing, but may operate at different speeds due to routing over the turnout side of the switch.

Frequent activations of the crossing if the railroad switches an industry siding near by.

## Factors Affecting Grade Crossings

- **Other crossings adjacent to the crossing**

- Effects of queuing, truck length, and clearance time
- Interconnection or independent operation
- Pedestrian refuges



Photo © Mike Loehr 2017

### **Mike Loehr:**

Other crossings adjacent to the crossing can have impacts from queuing and increased clearance time. Not all adjacent crossings are interconnected, resulting in independent operations. The crossings in the photo are two separate FRA crossings and are not interconnected. The gates operate independently of each other and may have queues extending over the adjacent crossing. There is not enough space between the center gates for a modern tractor trailer with 53' trailer design vehicle.

Pedestrian refuges between crossings may be required to protect pedestrians without having excessive clearance times.

## Factors Affecting Grade Crossings

- **Other Users in the same crossing**

- Light rail and freight sharing a common crossing on separate tracks



Photo © Mike Loehr 2017

### **Mike Loehr:**

At this crossing, the two nearest tracks are a light rail line operating with 7-minute headways (trains every 3.5 minutes, one in each direction), and a freight railroad on the single track.

This crossing is a single crossing with the vehicle gates operated by movements on either track with second train logic that prevents short gate up times between activations.

## Signals – Advanced Preemption

- Rutland, Vermont



### Mike Loehr:

The aerial photo shows a complex, but not unique example of a location where Advanced Preemption should be carefully considered.

This was the first two railroad grade crossings that were studied in Vermont after the regulations following the Fox River Grove accident were instituted.

East (above) in the photo is the Rutland Hospital, meaning that emergency vehicles travel over these crossing frequently and that excessive gate down times need to be avoided. In the Southwest corner is the State Fairgrounds, whose events generate large volumes of traffic.

For simplicity on this example, let's look only with the northbound train.

- The first step is to stop Northbound traffic from entering the area by starting a preemption at S. Main and Allen to change the Northbound to stop.
- Next, the flashers on the Allen Street Crossing are started to stop vehicles from entering the crossing.
- The third step is to give a green light at Allen and S. Main to empty the queue at Allen. This clears the Allen Street Crossing.

- During this time, the traffic signals that control the intersection of Park and S. Main over the crossing have been running their normal cycle to allow the traffic on S. Main to empty.
- Park Street is now stopped to allow the last bit of S. Main to move.
- South Main is now stopped at the grade crossing and the flashers are then started.
- Allen and S. Main are at a normal progression cycle so any queue from the Park St. intersection can clear Southbound.
- The S. Main Crossing is now cleared of vehicles.
- When the train leaves the island circuit on the S. Main crossing, the flashers stop and the intersection returns to the normal progression cycle.
- With change time and minimum greens, this added nearly 40 seconds to the Total Approach Time.

# Rutland Traffic Sequence

## Northbound Train

- Stop S. Main at Allen
- Start Flashers at Allen
- Green for WB Allen to clear queue
- Stop EB Park at RR
- Stop S. Main at RR
- Start Flashers at S. Main
- Stop Flashers at Allen
- Normal Progression at Allen and S. Main
- Stop Flashers at S. Main at RR
- Normal Progression at S. Main at RR

## Southbound Train

- Stop EB Park at RR
- Stop NB S. Main at Allen
- Green for WB Allen
- Start Flashers at Allen
- Clear WB Allen queue
- Stop S. Main at RR
- Start Flashers at S. Main
- Stop Flashers at S. Main
- Normal Progression at S. Main at RR and Allen
- Stop Flashers at Allen

**Mike Loehr:**

This slide lists the operations we just discussed.

## Why Could Additional Signal Work Be Required to Install a Crossing?

- **Whether a signal system is in use on a track**
  - Short Line and Regional Railroads have many tracks where there is no signal system installed.
  - Class 1 Railroads have signal systems on large portions of their tracks.
  - Installing Active Warning Devices on un-signalized track can be much simpler than installations on signalized tracks, but can involve additional circuitry to improve the shunt reliability.

### Mike Loehr:

Let's use the Rutland Advance Preemption project as a real world case.

The existing conditions were the following:

- Five Audio Frequency track circuits existed for the two crossings.
- Two approaches, two islands, and a shared approach were shared between the two crossings.
- The equipment was obsolete and the railroad was keeping it running by replacing other crossings and using the salvaged circuit boards as spares at this crossing.

When the two crossings in the Rutland project area were redesigned, the new and much longer approach circuits overlapped with the adjacent existing crossings. The two adjacent crossings were using the same obsolete technology, but they were independent because the existing approach circuits were set for Minimum Warning Time.

The new designs required more frequencies because of the overlapping crossings; however, there were not enough available frequencies from the obsolete salvaged boards, so the two crossing controllers had to be upgraded to modern Constant Warning Time devices.

## Why Could Additional Signal Work Be Required to Install a Crossing?

- **Obsolete technology prevents changes.**
  - Railroads have many generations of equipment in place.
  - Some equipment has been obsolete for decades, but the railroads use old equipment as spares.
  - The spares are limited to their original function, so the availability of all possible frequencies or modes of operations may be limited.
  - The cost of interfacing modern with obsolete equipment may be a significant percentage of the total replacement cost or actually cost more.

### Mike Loehr:

As we see in the Rutland example;

- Railroads have many generations of equipment in place.
- Some equipment has been obsolete for decades, but the railroads use old equipment as spares.
- The spares are limited to their original function, so the availability of all possible frequencies or modes of operations may be limited.
- The cost of interfacing modern with obsolete equipment may be a significant percentage of the total replacement cost or actually cost more



## Why Could Additional Signal Work Be Required to Install a Crossing?

- **Compatible technology, but conflicts with implementation**
  - Audio Frequency Constant Warning Time track circuits depend on differing frequencies to operate the circuits. Certain sets of frequencies cannot be used together if they are too close to the integer multiples of each other (harmonics).
  - Two, two-track crossings close enough to have overlap on their approach circuits can use all the available frequencies.
  - Equipment from two different manufacturers may have differing sets of compatible frequencies and adjacent crossings may not work together.

### Mike Loehr:

As we discussed on the last slide, we did have incompatible manufacturer's frequencies. The redesign also introduced some additional issues. Some of the frequencies available on the Constant Warning Time Controller had limitations on the length of Audio Frequency track circuits. Given the overall track conditions, stretching the lengths would have resulted in poor reliability. This would require reconstructing all of the track on the approaches to provide proper ballast section to increase the ballast resistance (Increasing the ballast resistance reduced the chance for false shunting).

The longer approach circuits were then overlapped with the adjacent crossings. The frequencies in the new equipment were not compatible with the existing circuit, and the method of measuring the electrical characteristics in the new Constant Warning Time Controller caused interference in the obsolete equipment.

The resolution was to replace the obsolete controllers in the adjacent crossings to ultimately save money that would have been spent in developing and implementing a retrofit to interface the two systems.

Fortunately, the Rutland project involved a much larger scope than the crossings, and

project contingency was used to cover the additional costs. On a Section 130 project, increasing the scope and cost would have been difficult.

This underlines the need to have the diagnostic teams properly scope the projects taking into account the compatibility of the equipment.

## Questions & Discussion

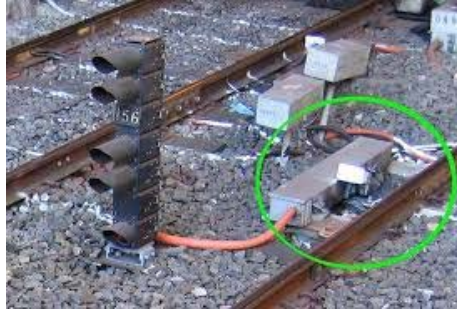

# Thank You

<http://upload.wikimedia.org/wikipedia/commons/thumb/3/38/Signal-and-train-stop-melbourne.jpg/300px-Signal-and-train-stop-melbourne.jpg>



U.S. Department of Transportation  
Federal Highway Administration



### Mike Loehr:

That is the end of the presentation, we will now open the phones for questions and answers.

As a quick side note, the silver box in the picture is a Automatic Train Stop trip stop that applies the brakes on a train going past a red signal. It there to keep me from over running my scheduled time.

## Upcoming Webinars

Improving Grade Crossing Safety  
Using Predictive Analytics and New Technology  
November 7, 2018  
1:30-3:00 p.m. EST



Richard Mullinax (NCDOT) and Paul Rathgeber (UPRR) will be presenting at this webinar.

The meeting invitation and registration link will be sent out shortly.

# Contacts

- **R16 Subject Matter Experts:**

- Michael J. Loehr, PE  
Jacobs  
Global Technology Leader - Transit & Rail  
Track and Civil Engineering  
+1.570.575.4692 Mobile  
[Michael.Loehr@jacobs.com](mailto:Michael.Loehr@jacobs.com)
- Kenneth Shields, PE  
Jacobs  
Regional Technology Leader - Transit & Rail  
+1. 201.397.3819 Mobile  
[Kenneth.Shields@jacobs.com](mailto:Kenneth.Shields@jacobs.com)

## For More Information

### Product Leads:

**Kate Kurgan**  
AASHTO Co-Product Lead  
[kkurgan@aaashto.org](mailto:kkurgan@aaashto.org)

**Pam Hutton**  
AASHTO Co-Product Lead  
[phutton@aaashto.org](mailto:phutton@aaashto.org)

**Kate Hulbert**  
**FHWA**  
[kathleen.hulbert@dot.gov](mailto:kathleen.hulbert@dot.gov)

**Hal Lindsey**  
R16 Project Manager  
[hal.lindsey@jacobs.com](mailto:hal.lindsey@jacobs.com)

### Additional Resources:

**GoSHRP2** [fhwa.dot.gov/GoSHRP2](http://fhwa.dot.gov/GoSHRP2)  
**Website:**

**AASHTO SHRP2** <http://shrp2.transportation.org>  
**Website:**

**R16 Product** [http://shrp2.transportation.org/Pages/R16\\_RailroadDOTMitigationStrategies.aspx](http://shrp2.transportation.org/Pages/R16_RailroadDOTMitigationStrategies.aspx)  
**Page**

For additional information, we encourage you to contact the product implementation leads from FHWA and AASHTO.

The GoSHRP2 and AASHTO SHRP2 Websites are where you can find technical information about the products. GoSHRP2 product pages will provide a variety of helpful resources including fact sheets, videos, and links to product research.

We encourage you to sign up for **GoSHRP2 email alerts** to get the latest information on SHRP2 delivered right to your inbox.