



# KYTC – Kentucky Transportation Cabinet

Date: November 17, 2015

Kevin Sandefur, P.E.

Bridge Design and Maintenance Branch

Division of Structural Design, KYTC

Kevin.Sandefur@KY.gov

502-564-4560



U.S. Department of Transportation  
Federal Highway Administration



TRANSPORTATION RESEARCH BOARD  
OF THE NATIONAL ACADEMIES

# ABC in Kentucky

## Reasons For Using ABC

- **Bridge & Superstructure Replacements**
- **Urban - High Traffic Volumes**
- **Rural Areas – Substandard or Non Existent Detours**

# KY's ABC Experience

Harlan County – KY 219 over Wallins Creek





# KY's ABC Experience





# KY's ABC Experience



# KY's ABC Experience





# KY's ABC Experience





# KY's ABC Experience



# KY's ABC Experience





# KY's ABC Experience





# KY's ABC Experience



# KY – 6 over Stewarts Creek

## Selecting Kentucky's SHRP2 Project

### Knox County, KY 6 over Stewart's Creek

- Short Single Span
- Use Rolled Steel Girders
- Duplex Coating System
  - Galvanizing
  - Painting
- Concrete Protection
  - Stains
  - Deck Sealers

# KYTC's SHRP2 Bridges - Design

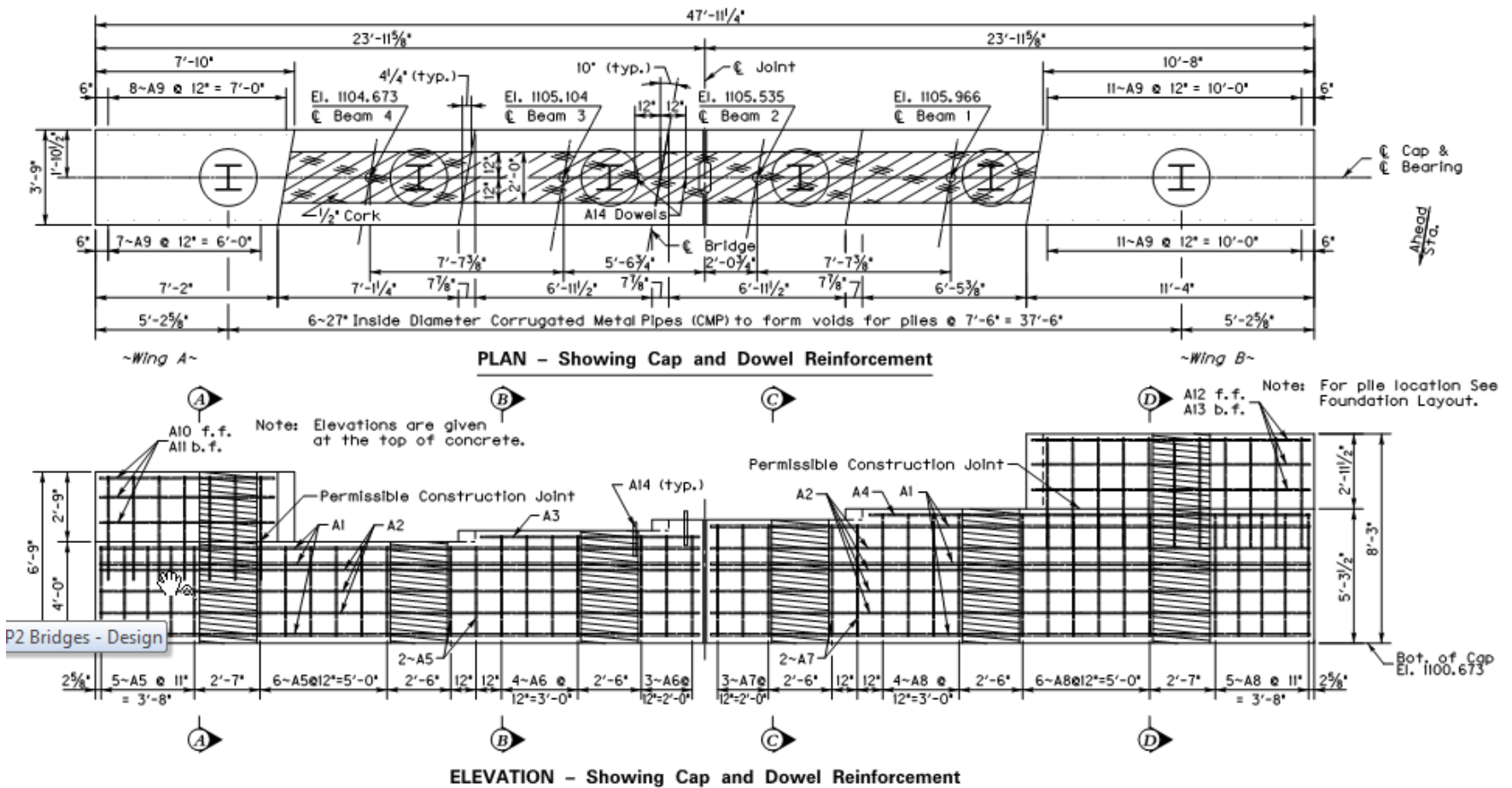



# KYTC's SHRP2 Bridges - Construction

## Beam Fabrication

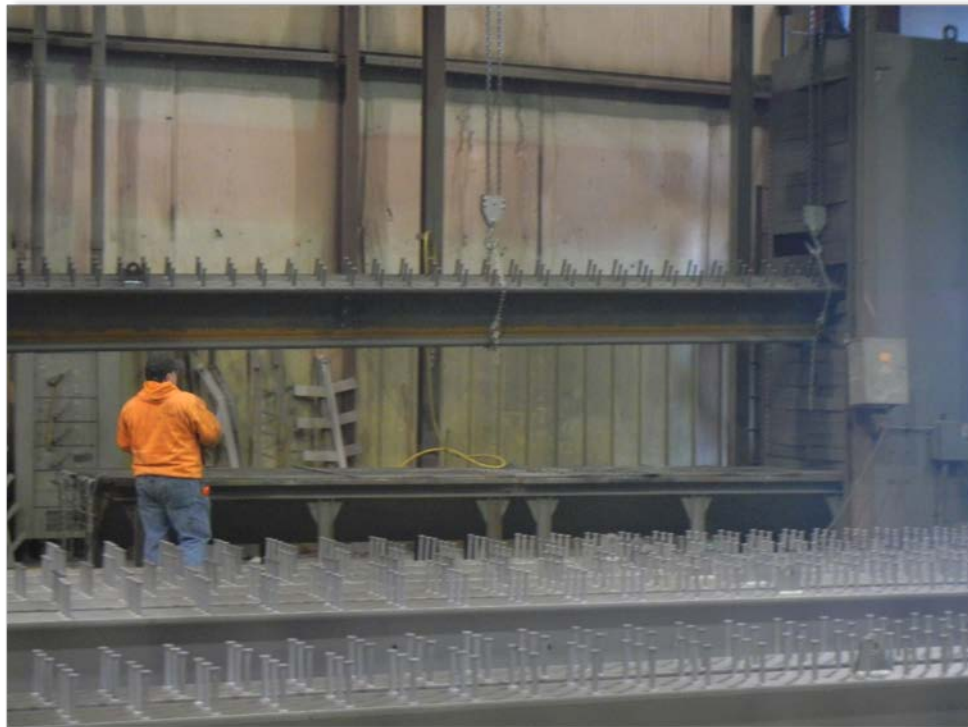

# KYTC's SHRP2 Bridges - Construction

## AZZ, Nashville



# KYTC's SHRP2 Bridges - Construction





# KYTC's SHRP2 Bridges - Construction

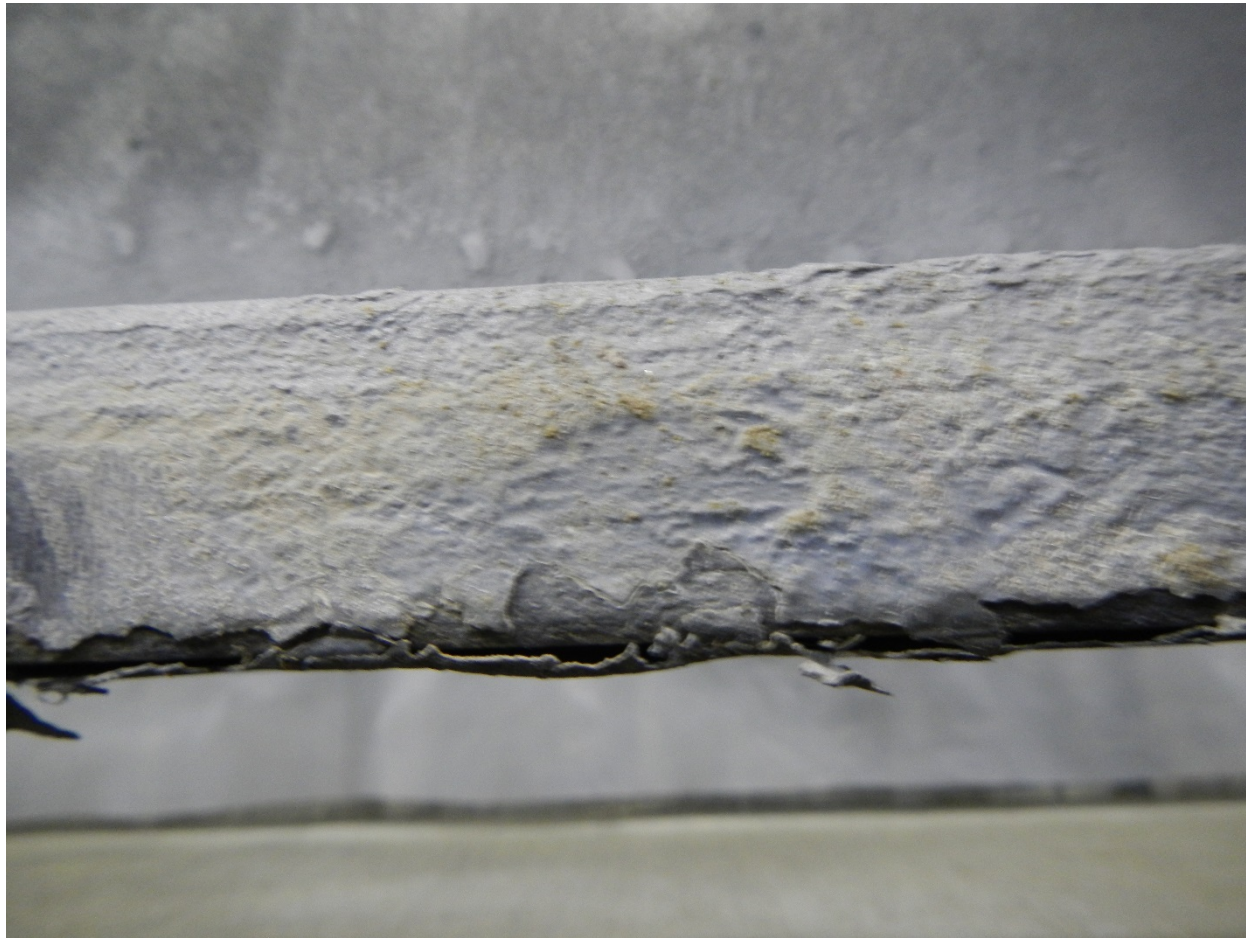

# KYTC's SHRP2 Bridges - Construction





# KYTC's SHRP2 Bridges - Construction





# KYTC's SHRP2 Bridges - Construction



# KYTC's SHRP2 Bridges - Construction

## Lynn Camp Creek Bridge





# KYTC's SHRP2 Bridges - Construction

## Stewarts Creek Bridge





# KYTC's SHRP2 Bridges - Construction





# KYTC's SHRP2 Bridges - Construction





# KYTC's SHRP2 Bridges - Construction





# KYTC's SHRP2 Bridges - Construction



# KYTC's SHRP2 Bridges - Construction



# KYTC's ABC Bridge Experience

## Lessons Learned

- Decide Early to Use ABC
- Keep Precast Units Simple
- Waive Precast Precertification Requirements
- Galvanization Issues
  - Blast Clean Structural Steels to SSPC SP 10
  - Specify Si and P Content
- Closure Pour Connection Details
  - Time
  - Price



# KYTC's ABC Bridge Experience

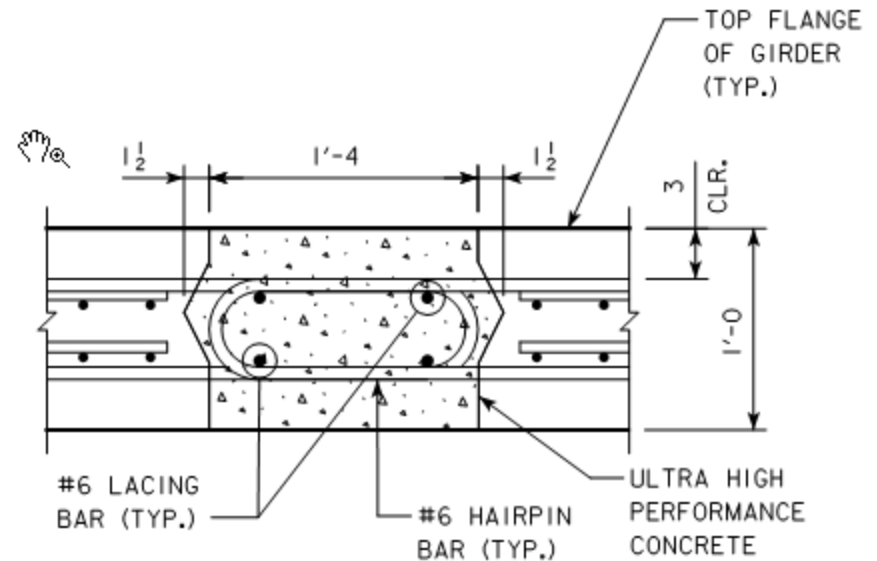
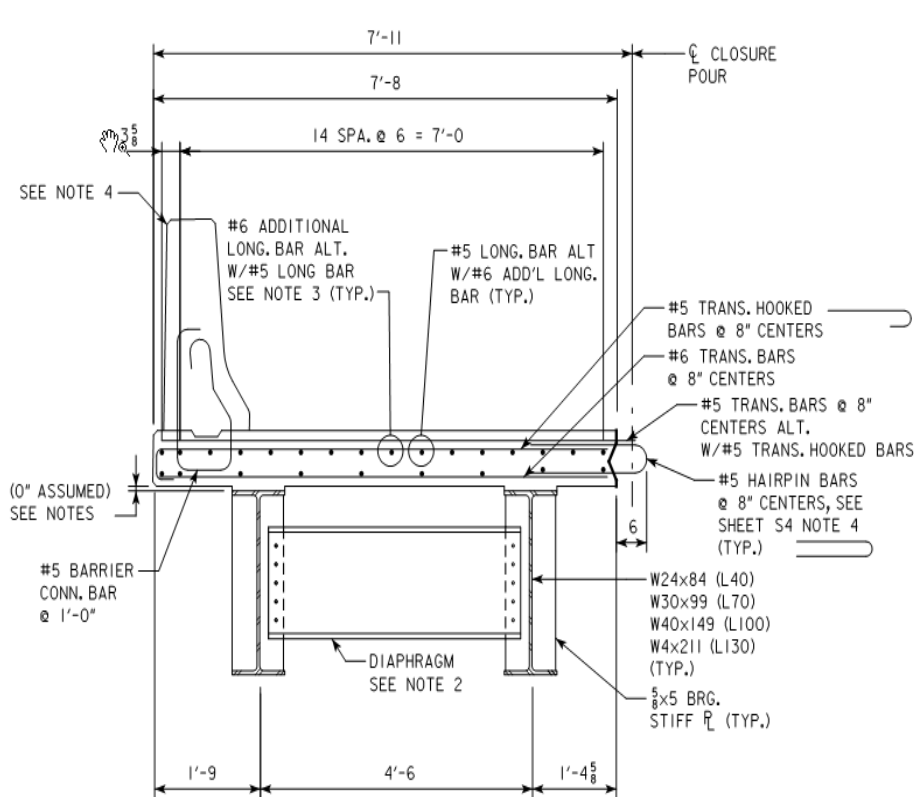

## SHRP2 Rapid Renewal Toolkit

- Quicker Field Connection
- Smaller Closure Pour
- Allows for field adjustment

# KYTC's ABC Bridge Experience

## KYTC Reservations about ABC.

- Longevity of Connection Details
- Longevity of Joints
- Expense and availability of UHPC
- Use on multi-span structures
- Cost versus conventional construction

# KYTC's ABC Bridge Experience

